

**ALMA COLLEGE CONDITIONS ASSESSMENT PROJECT**  
Midpeninsula Regional Open Space District  
Santa Clara County, CA

Phase I: Assessment of Existing Conditions



Knapp Architects

March 2010



---

**TABLE OF CONTENTS**

---

**ALMA COLLEGE CONDITIONS ASSESSMENT PROJECT  
PHASE I – ASSESSMENT OF EXISTING CONDITIONS**

- I. Executive Summary ..... 4
- II. Assessments & Analyses
  - A. Introduction..... 11
  - B. Geotechnical Assessment..... 12
    - Figure B-1. Site Location Map
    - Figure B-2. Site Plan
    - Figure B-3-8. Logs of Test Pits 1 through 6
    - Figure B-9. Regional Geologic Map
    - Figure B-10. Regional Fault Hazard Zone Map
    - Figure B-11. Map of Major Faults and Earthquake Epicenter  
In the San Francisco Bay Area
    - Figure B-12. Modified Mercalli Intensity Scale
  - C. Structural Assessment..... 24
    - Figure C-1. Chapel: New Shear Walls Proposed
    - Figure C-2. 1950 Library Addition: Window Infill Proposed
    - Figure C-3. Classroom: New Shear Walls & Hardy Frames Proposed
  - D. Architectural Assessment..... 38
    - Exhibit D-1. Architectural Survey
    - Exhibit D-2. Historic & Current Photographs of Buildings
    - Exhibit D-3. Alma College Site Conditions & Adaptability
  - E. Landscape Assessment ..... 41
    - Exhibit E-1.1 - Walls Establishing Level Area
    - Exhibit E-1.2 - Level Area of Campus Core
    - Exhibit E-1.3 - Historic Spatial Enclosure
    - Exhibit E-1.4 - 2009 Spatial Enclosure
    - Exhibit E-1.5 - Historic Pedestrian Circulation
    - Exhibit E-1.6 - 2009 Pedestrian Circulation
    - Exhibit E-2. Historic Site Photographs of Alma College
    - Exhibit E-3. Landscape Features Plan
    - Exhibit E-4. Landscape Features - Survey of Conditions
    - Exhibit E-5. Landscape Features Field Sketches: L1, L4, L6, L9
    - Exhibit E-6. Current Photographs of Landscape Features
    - Exhibit E-7. Alma College Ornamental Plant Resource Inventory  
(Park, Keith W. "Alma College Ornamental Plant Resource  
Inventory," Alma College volunteer horticulturalist, 22 July  
2009.)

F. Cultural Landscape Analysis ..... 45  
    Exhibit F-1. Alma College Fire Insurance Map  
    Exhibit F-2. Summary of Previous Site Assessments  
    Exhibit F-3. Alma College Site History  
    Exhibit F-4. Alma College Cultural Landscape Contributing Elements  
  
G. Future Development Considerations ..... 53  
    Exhibit G-1. Considerations for Future Use  
  
III. Conclusion..... 58  
IV. Bibliography..... 60



## I. EXECUTIVE SUMMARY



---

## **I. EXECUTIVE SUMMARY**

---

### **Description of Alma College Conditions Assessment Project**

The Alma College Conditions Assessment is a project undertaken by Midpeninsula Regional Open Space District (MROSD or District) to assess the existing conditions of the former Alma College site, understand its constraints and opportunities, and develop treatment recommendations for its future use and management. The conditions assessment is divided into three phases of study:

Phase I - Assessment of Existing Conditions

Phase II - Preparation of Treatment Recommendations

Phase III - Final Report Preparation

The following project team prepared this study in cooperation with, and under the direction of, the Midpeninsula Regional Open Space District:

Architect: Knapp Architects

Geotechnical Engineer: Treadwell & Rollo, Inc.

Structural Engineer: Structural Design Engineers

Landscape Architect: PGAdesign

### **Alma College Site Description and History <sup>1</sup>**

In order to appreciate the size and depth of this study it is important to understand the Alma College site and its layered history.

The Alma College campus is located near District Gate BC04 on Bear Creek Road in Bear Creek Redwoods Open Space Preserve, in unincorporated Santa Clara County near the Town of Los Gatos. For the purposes of this study, the Alma College site is defined as extending from Bear Creek Road near Upper Lake and including all features contained along the flat-topped ridge line to and including the site of the former Roman Plunge. The sides of the flat-topped ridge are established by retaining walls in the southeast and by the road that encircles Upper Lake in the northwest part of this area. This defines the historic core of the Tevis estate and later Jesuit seminary.

The site was settled and timber was harvested and milled in the 1850's. The site was later developed into a rural estate by James L. Flood (1894-1905) and Dr. Harry L. Tevis (1905-1934). In 1934, after Tevis' death, the Jesuit Sacred Heart Novitiate of Los Gatos purchased the property and established the first Jesuit theological seminary on the west coast, the Alma College campus. The Jesuits converted the Tevis house and library, both built in 1909, into a faculty residence and chapel, respectively, and built a library in 1934 and dormitory buildings in 1935. In 1949, the Jesuits built a two-story concrete addition onto the 1934 library structure.

In 1969, the seminary was relocated to the Graduate Theological Union at the University of California, Berkeley and the Alma College campus was leased to a private boarding

---

<sup>1</sup> Midpeninsula Regional Open Space District. "Request for Proposals for Historical Architectural Consulting Services: Alma College Conditions Assessment Project." Los Altos, California, 23 March 2009, pp. 1-2.

school. In 1970, the dormitory buildings were demolished, and the faculty residence burned down, leaving only a remnant of the structure. In 1989, the property was sold to a private developer with plans to build a golf course and country club, but the site was never developed. In 1999, the Peninsula Open Space Trust purchased the property and subsequently sold it to Midpeninsula Regional Open Space District. As part of the Bear Creek Redwoods Open Space Preserve, the site is included in the Draft Sierra Azul / Bear Creek Redwoods Master Plan, currently under development. The District envisions Alma College as a focal point providing public access opportunities. In order to determine its future treatment, the District commissioned this study to determine the condition and adaptability of site features, historical significance and integrity to develop a feasible plan to rehabilitate the site for future public access and use.

**Existing Conditions Survey**

Since before the site was acquired by the Midpeninsula Regional Open Space District, it was abandoned of use and fell into disrepair. The project team first reviewed background documents, considered the site’s history, development and previous reports and surveys. Using this background information, the project team evaluated the current site conditions and deterioration of buildings, landscape features, ruins, vegetation, and other aspects of the historical landscape. The various disciplines focused their survey on the structures and features listed below.

Structures and Features Survey List:

Survey by G = Geotechnical, S = Structural, A = Architectural, L = Landscape

1. Main Structures:
  - Chapel G, S, A
  - Library (1934 and 1950) G, S, A
  - Classroom building G, S, A
  
2. Ancillary Structures:
  - North Walkway A
  - East Walkway A
  - Garage/Residence A
  - Tevis Remains including Carports A & B A
  - Dormitories A
  - Wood Shed A
  - Concrete Masonry Unit (CMU) Shed A
  
3. Landscape Features: (See landscape survey for full list)
  - Upper Lake (including fountain & infrastructure) L
  - St. Joseph Shrine L
  - Marian Shrine L
  - Lily Pond, Roman Plunge and Field L
  - Wooden Cross L
  - Central Fountain L
  - Concrete & Brick Retaining Walls & Aqueduct G, S, L
  - Trees & Landscape L
  - Circulation - Paths and Roads L
  - Brick Driveway remains near carport L
  - Entry Gates L

- Wood Retaining Wall L
- Wooden Fencing L
- Flagpole L
- Boulders SE of Upper Lake L

**Geotechnical Assessment**

The Geotechnical Assessment included study of building foundations and retaining walls through test pit excavation. The test pits verified soil conditions and depth of footings. Review of background documents provided by the District and Santa Clara County established that the site is in close proximity to the main trace and subsidiary traces of the San Andreas Fault. The county geologist recommended a fifty-foot set back from seismic faults for buildings that would be used as habitable structures for the redevelopment of the Alma College site. The Classroom and Garage buildings at the south edge of the main campus axis are directly adjacent to a subsidiary trace and cannot be used as habitable structures if rehabilitated due to seismic hazard. The 1934 and 1950 Library and Chapel buildings, on the north edge of the main campus axis, are a sufficient distance from identified fault traces and can be used as habitable buildings. The 1950 Library structure is within fifty feet of a subsidiary trace but it has been sufficiently designed for strength and would require a few structural changes to meet the current requirements for seismic retrofit.

**Structural Assessment**

The Structural Assessment took into account the findings of the geotechnical engineer and studied each of the main buildings to determine requirements for a seismic retrofit. Basic seismic retrofit of the Chapel would involve installation of plywood roof diaphragm, improving roof to wall connections, installation of plywood shear walls, reinforcement or replacement of brick foundations, and improvement of roof truss connections. In addition, the north porch area including its brick stair, below grade story and building foundations would need to be coordinated with the strengthening of the adjacent north retaining wall. The components of the Library, the 1934 and 1950 structures, are both concrete and require minimal intervention. Both structures would require re-roofing, repair of substrate damage and installation of a plywood roof diaphragm. At the 1950 building, concrete cracks at non-structural columns at the south façade would be repaired and two north-facing windows would be infilled for shear strengthening. Strengthening of the adjacent north retaining wall would also require coordination with the Library building. The Classroom building would require more intervention due to its proximity to the subsidiary trace fault. The existing roof is warped and weak and needs repair and retrofit. The number of roof trusses would need to be increased and roof to wall connections improved. A new plywood roof diaphragm would need to be installed. Plywood shear panels and Hardy Frames/Simpson Strong Walls would need to be installed at exterior walls also. Foundations would require localized strengthening, addition of new foundations at demising walls between sections of the building. Typically, at each building, wood dry rot and water damage would need to be investigated and repaired.

**Architectural Assessment**

The Architectural Assessment evaluated the condition of the three main buildings, the Chapel, Library and Classroom buildings, and Ancillary Structures to determine

conditions that require rehabilitation. The site has been left to deteriorate without maintenance for years and it is important to note that the extent of repair surpasses that of buildings in continuous use.

Rehabilitation of the wood-framed Chapel building would entail reroofing, repair of exterior wood deterioration at eaves, rakes and trim, replacement of wood wall shingles in kind where damaged or removal is required for new shear walls, repainting, repointing of foundation brick mortar joints, repair of warped doors and broken glazing, window repair, interior finish cleaning and repair, and mitigation measures to deal with bat and rodent populations.

The Library is comprised of the 1934 and 1950 concrete structures. The 1934 Library rehabilitation would require reroofing, repair of exterior wood deterioration at eaves and rake and dormers, removal of paint vandalism and repointing at brick facing, repair of windows and doors, removal of the interior non-historic loft and stair, vegetation management and minor grading for drainage. The 1950 Library rehabilitation would require reroofing, replacement or repair of the clay tile roof, repair of stucco and concrete finish damage, repainting, repair of broken window glazing and damaged frames at large fixed wood window and steel sash, repair of warped steel sash doors with broken glazing, and repair of interior finishes including water damage.

The Classroom would require substantial repairs to the warped roof, reroofing, repair of extensive wood deterioration at eaves, rakes and trim, replacement of wood shingles in kind where damaged or removal is required for new shear walls, application of finish coat to protect wood materials if paint was not original used, repointing of foundation brick mortar joints, repair of doors and windows and broken glazing, removal of non-historic interior materials, repair of interior finishes, and minor mitigation to deal with bat and rodent population.

Along with the specific repairs that would be required to rehabilitate the deteriorated condition of the three main buildings, the addition of gutters and downspouts, upgrade of mechanical, electrical and plumbing infrastructure to code and for a new use, management of vegetation, consideration of site drainage, and renovation of interiors for a new use would also need to be considered.

Ancillary structures in ruin include the Tevis House / Faculty Residence, destroyed by fire, and Dormitory buildings, demolished after the later Alma College period. Debris and vegetation should be removed from these ruins and minimal repair performed to protect the remains from further deterioration. The ruins should be assessed for hazards and remediation applied. The Garage / Residence is mostly intact but is in close proximity to a subsidiary trace fault and cannot be made habitable. As a secondary structure, it could be demolished or retained but made inaccessible to the public depending on the level of hazard management required. At the North Walkway, the posts, beams and roof are in poor condition. The walkway roof rests on the adjacent buildings and would require substantial retrofit and repair, replacement in-kind, or removal. The East Walkway was damaged by fire and would require major repair and stabilization of the remaining bays, complete reconstruction or removal. The Wood Shed is in a partially collapsed state. The construction date of the Wood Shed is unknown but it retains some characteristics of the early Alma College period buildings. As a minor structure, it could either be demolished or repaired and brought to plumb to contribute to the character of the site. The concrete-

block Shed to the north of the Dormitory ruins is non-historic and could be demolished or used for a secondary function.

### **Landscape Assessment**

The Landscape Assessment was the first of its kind, for this site, taking into account the various landscape features from each period of the site's history. The landscape study determined the condition of over thirty features. Rehabilitation of the landscape would include reinstating the primary pedestrian access through the center of the site and the historic spatial enclosure with the extant buildings and large masses of vegetation, maintaining the discrete character-defining features through repair and vegetation management, and managing introduced species and native species to improve the legibility of the Alma College cultural landscape. The landscape features, along with its buildings, are integral to the interpretation of the site as a cultural landscape. In the future, interpretation may be facilitated by a visitor brochure or non-intrusive site maps that show historic pictures of how the features once appeared. Contemporary factors bear on the treatment and maintenance of the site: site safety, accessibility (Americans with Disabilities Act), degree to which it is open to the public, connections to the broader landscape for hiking and equestrian trails and access to and use of irrigation water.

### **Cultural Landscape Analysis**

Under the California Register of Historic Resources (California Register), properties may be defined as sites, buildings, structures – such as bridges or dams – objects, or districts – including cultural landscapes. This study considered the Alma College site as a cultural landscape, which are evaluated for eligibility to the California Register as districts. Properties are eligible to the California Register if they are significant under one or more of four criteria for (1) association with important historical events, (2) association with important persons, (3) construction that is the work of a master or as an example of superior design, or (4) archaeology. If a property is significant with respect to these criteria, it is evaluated under the California Register's seven aspects of integrity to verify that it retains the physical characteristics which convey its historic significance.

The Alma College site is significant as a cultural landscape under Criterion 1 of the California Register for its historical parallels with the broader events of California history. This study defines the period of significance as circa 1850 to 1951. Although integrity has been compromised due to the loss of several buildings and features, lack of maintenance, and vegetation overgrowth, the Alma College site retains integrity and expresses periods of the site's history: Milling (1850), Tevis (1906-1934), Alma College (1934-1949), and the Later Alma College (1950-1969). The extant structures and features, even those in ruin, still convey the cultural landscape's significance as integral remnants with interpretive value.

It is recommended that, in Phase II, a landscape historian perform additional research and prepare formal documentation to nominate the Alma College cultural landscape as a California Register district.

### **Future Development Considerations**

In determining the site's future use, the cultural landscape's significance and integrity is an important parameter. The Alma College cultural landscape evidences a number of

distinct periods. If all features of any one period were lost, then it would be impossible to understand the site's association with that period removing its contribution to the significance of the site. It is important, then, to consider the retention and demolition of structures and features carefully. Planning for future development must also consider the needs and requirements of the community, MROSD, Santa Clara County and the California Environmental Quality Act (CEQA).

The *Secretary of the Interior's Standards (Secretary's Standards)*, formulated by the National Park Service, is the benchmark for preservation and rehabilitation of historic properties. The future treatment of the site is intended to comply with the *Secretary's Standards* including the rehabilitation of historic structures. Once a site use concept has been developed, the feasibility of compliance with the *Secretary's Standards* can be readily addressed. As a cursory benefit, application of the *Secretary's Standards* can also minimize the environmental review for a proposed project under CEQA.

Assuming it would not be feasible to undertake a massive rehabilitation program to return the Alma College property to its historic condition, future development and rehabilitation of the site may be performed in manageable stages:

- Stage 1 - Initiate rehabilitation of the site, focusing on vegetation management, circulation and minor stabilization of landscape elements and ruins that are not dependent on the retaining walls for support.
- Stage 2 - Strengthen the site retaining walls to stabilize buildings and elements that depend on the retaining walls for support.
- Stage 3 - Rehabilitate buildings and site features including structural retrofit and architectural repairs.
- Stage 4 - Construct minor structures for support of the site or to bring a new commercial use to the site without prohibiting open space recreational uses and interpretation of the cultural landscape.

The stages suggest the priority in which rehabilitation work could be performed for the overall site. For the rehabilitation of individual buildings, it is more difficult to suggest clear-cut priorities in advance of basic decisions on site use and budget. The layered site history and various conditions of features presented in this report in addition to the District's requirements and goals for management of this property create a complex backdrop for decision-making. To assist in the decision-making process, this report offers a tentative order (or hierarchy), to be explored further in Phase II, in which the buildings could be approached:

1. The Chapel, associated with Tevis and Alma College periods, is the most historically important intact building and is critical to the legibility of the cultural landscape. Its large open interior space is compatible with assembly uses.
2. The 1934 Library is associated with the Alma College period. Although it is small and not as adaptable to some uses, its rehabilitation cost might be less than that of the Chapel.
3. The 1950 Library is from the Later Alma College period. Its large size and style are less compatible with the earlier buildings but the 1950 Library is relatively adaptable for a variety of uses. Although it may have a lower rehabilitation cost per square foot than the Chapel and 1934 Library, its long-term maintenance cost could be higher.



Future use, frequency of use, and cost of rehabilitation and maintenance are major factors in determining whether to demolish structures or retain and reuse them. The following points should be considered and balanced to extract the maximum value from the site in planning future development:

1. The significance of elements contributing to the cultural landscape including buildings, landscape features, circulation, topography, spatial relationships, and vegetation.
2. Condition and cost of rehabilitation of buildings, landscape and landscape features.
3. Priorities established by the District and Draft Sierra Azul / Bear Creek Redwoods Master Plan including safety, connection to trails and overall planning considerations.
4. Building use and frequency of use.
5. Current code requirements including accessibility and utilities infrastructure required by a new use.
6. Effect of future plan on indigenous animal life such as bats.
7. Amount and sources of funding required to pursue rehabilitation.

## **Conclusion**

The preliminary information gathered in Phase I is broad and provides a basis for planning but additional studies on the buildings and retaining walls would be necessary to provide adequate information for Phase II cost estimation and a future development.

In Phase II, the project team would develop treatment recommendations based on the conditions assessment and the defined cultural landscape. The project team would consult with the Midpeninsula Regional Open Space District which would provide direction on the level of detail and attention paid to each site feature. The project team would do additional investigation of features as necessary to refine proposed treatment recommendations. A bat biologist would review the treatment recommendations and provide a summary to address mitigation for the indigenous bat and rodent populations within the existing buildings. The overall treatment plan would be provided to the cost estimator. The cost estimate and potential funding sources would be considered with awareness of any issues that may limit or exempt the project from funding in the future. An implementation plan would be developed to include a list of features, deterioration and a schedule for short- and long-term tasks including inspections of the site.

In Phase III, the findings of Phase I and II would be compiled into a final report to be submitted to the District's Board of Directors for review and comment. The project team would participate in meetings with the District and its Board of Directors to discuss the development plan and address the feasibility of rehabilitation in terms of cost and benefit.

The Alma College site is valued by the local community as an important cultural resource. The overall goal of the Alma College Conditions Assessment Project is to facilitate the site's future development as a major trailhead of the larger Midpeninsula Regional Open Space District to enhance its availability to and use by the community as an important interpretive site conveying layers of local history.



## **II. ASSESSMENTS & ANALYSES**



**II. ASSESSMENTS & ANALYSES**  
**SECTION A - INTRODUCTION**



---

**II. ASSESSMENTS & ANALYSES**  
**SECTION A - INTRODUCTION**

---

This document covers Phase I, existing conditions survey and analysis. In order to understand the Alma College site, it is important to define the major constraints of the site and then consider more specific existing conditions. So, Phase I is divided into two parts. Part 1 considers the most critical preliminary geotechnical and structural conditions that affect the site as a whole and the stability of site features. These studies provide a backdrop for Part 2, the architectural and landscape studies, which focus on the condition of specific character-defining structures and features of the site, how they contribute to a cultural landscape and how this information correlates to the findings of Part 1. The combined assessment, in Phase I, provides existing conditions data and a set of parameters - constraints and opportunities - that will assist in planning future development in Phase II.

The study has been prepared by a project team addressing geotechnical, structural, architectural and landscape issues in cooperation with, and under the direction of, the Midpeninsula Regional Open Space District. The project team includes:

Historical Architect: Knapp Architects  
Frederic H. Knapp, Principal  
Ruchira D. Nageswaran, Project Architect

Geotechnical Engineer: Treadwell & Rollo, Inc.  
John Gouchon, Principal  
Serena Jang, Senior Engineer  
Christopher R. Hundemer, Senior Geologist

Structural Engineer: Structural Design Engineers  
John W. Laws, Principal

Landscape Architect: PGAdesign  
Cathy Garrett, Principal

The geotechnical, structural and landscape summaries which follow are inserted text from each discipline, some in letter form. The exhibit diagrams and figures should be actively referenced in the reading of this document.





## **II. ASSESSMENTS & ANALYSES**

### **SECTION B - GEOTECHNICAL ASSESSMENT**

- Figure B-1. Site Location Map
- Figure B-2. Site Plan
- Figure B-3-8. Logs of Test Pits 1 through 6
- Figure B-9. Regional Geologic Map
- Figure B-10. Regional Fault Hazard Zone Map
- Figure B-11. Map of Major Faults and Earthquake Epicenter  
In the San Francisco Bay Area
- Figure B-12. Modified Mercalli Intensity Scale



---

**II. ASSESSMENTS & ANALYSES**  
**SECTION B - GEOTECHNICAL ASSESSMENT**

---

This letter presents the results of our geotechnical evaluation conducted as part of the rehabilitation evaluation for the Alma College Campus located within the Bear Creek Redwoods Open Space Preserve in unincorporated Santa Clara County California, as shown on Figure B-1, Site Location Map. The site is presently owned and managed by the Midpeninsula Regional Open Space District (MROSD).

Portions of the site are within an Alquist-Priolo special studies zone for the nearby San Andreas fault; the site is also located on a large, deep-seated bedrock landslide (named the Black Road Landslide). The objective of this investigation was to evaluate the site's geologic setting and provide preliminary geologic and geotechnical conclusions concerning existing structures located on a portion of the property.

**1.0 PROJECT DESCRIPTION**

The property is currently closed to the public, and we understand based on conversations with District representatives that MROSD is assessing the condition of the campus for possible rehabilitation of the three main structures, surrounding landscape features, and associated ancillary structures. The central portion of the campus contains the three main structures: the classroom building, chapel, and library, as well as several landscape features, including concrete and masonry retaining walls up to about 20 feet in height.

This letter provides the results of our geotechnical assessment for Phase I, which includes the assessment of existing conditions of the Alma College Conditions Assessment project.

**2.0 SCOPE OF SERVICES**

For this letter report, we conducted a field investigation and performed geotechnical reviews and analyses, that included:

- attending a preliminary site meeting with the project team and representatives from MROSD on 2 July 2009,
- reviewing published geologic literature and maps of the site and vicinity,
- consulting with the Santa Clara County Geologist, Mr. Jim Baker,
- reviewing a prior geologic fault study report by John Coyle & Associates dated 16 June 1997, and several supplemental letters issued by that consultant and Mr. Baker,
- excavating and logging six hand-dug test pits on the site,
- developing preliminary geotechnical criteria for the structures,
- and preparing this letter.

### 3.0 FIELD EXPLORATION AND LABORATORY TESTING

We performed a subsurface exploration program consisting of excavating and logging six test pits, designated TP-1 through TP-6. The approximate locations of our borings and test pits are shown on Figure B-2. One test pit was excavated at each of the three main structures to evaluate the foundation of each structure, and three test pits were excavated adjacent to site retaining walls to expose the bottom of the foundation for the walls.

Between 29 July 2009 and 7 August 2009, our geologist and engineers observed the conditions exposed in the test pits. The test pits were excavated by Soil Stability Construction (SSC) to depths ranging between about 4 and 15 feet beneath the existing ground surface. Each pit measured approximately two feet by three feet in plan dimension. The deeper pits were shored during excavation using wood shoring in accordance with the OSHA approved shoring design by SSC.

Following excavation, our geologist logged the pits to their full depth by observing and characterizing the exposed soil, fill, bedrock, and foundation elements to evaluate the depth of existing foundations and their supportive materials. Logs of the test pits are presented on Figures B-3 through B-8.

The depth of test pit excavation was established by our geologist based on the conditions observed in each pit. Our geologist collected samples of the subsurface materials for laboratory classification. After logging was complete, the test pits were backfilled with the excavated soil, compacted in lifts.

### 4.0 PREVIOUS INVESTIGATIONS

A preliminary fault study location investigation was performed by John Coyle and Associates (JCA) in 1997 for a prior proposed golf course development at the site which was not built. The results of that investigation were presented in a report dated 16 June 1997. That investigation included reviewing pertinent published geologic maps and reports, reviewing stereo-paired aerial photographs, and excavating and logging six exploratory trenches, designated Trenches 1 through 6, in the area of the subject buildings. The trenches were excavated roughly perpendicular to the local trend of the San Andreas fault, and shadowed the widths of the three structures. Trenches 5 and 6, located on the southeast and northwest sides of the classroom building respectively, encountered a subsidiary trace of the fault trending beneath the southwest side of the structure. Trench 3, a longer trench located between the classroom and library buildings and Trench 2, a longer trench located northwest of the classroom building also encountered this feature at their southwest end. No other fault features were observed in Trench 3 in the areas of the library and chapel buildings. Trenches 1 and 4 were located northeast of the development.

Subsequent to that investigation, JCA issued a letter of clarification on 30 September 1997 to clarify what the displacement along this feature could be during a major earthquake on the San Andreas fault. They concluded that there could be up to ½-foot of cumulative displacement across the main fault and all the subsidiary traces within a zone *“a couple of hundred feet wide parallel to the main trace of the San Andreas fault..”* and that locally any trace could expect up to 3 inches of displacement.

On 31 October 1997, the County Geologist Mr. Jim Baker issued a written statement stating that “Combined, Coyle’s reports are adequate for evaluation of faulting hazards at the former Alma College site.”<sup>2</sup> He also references recommended setbacks provided in the original JCA investigation report for any new structures proposed at the site.

On 16 April 1998, the Santa Clara Valley Water District (SCVWD) issued a letter in response to a landslide stability study by Questa Engineering Corporation dated 25 March 1998.<sup>3</sup> The response letter by SCVWD described concerns with the development of a golf course on a deep-seated landslide. They concluded that timber harvesting to create the golf course and irrigation from the golf course could cause the nearby creeks to flow perennially and change the water balance in the landslide. This would saturate the landslide mass earlier in the rain season, resulting in a longer period for excess pore pressures to develop in the landslide. They described the effects should the Black Road Landslide move, as significant to catastrophic, with the potential for a sudden release of water from the Lexington Reservoir located near the toe of the landslide. The letter also provided a number of requirements for a detailed geologic study of the landslide prior to the golf course development.

Questa Engineering Corporation issued a letter dated 21 April 1998 responding to the 16 April 1998 SCVWD letter. This letter provided specific methods for their geologic investigation of the landslide during the golf course study.

## **5.0 SITE CONDITIONS**

### **5.1 Regional Geology**

As described above, the site is located within an area identified as the deep-seated Black Road Landslide. We anticipate that the landslide consists of displaced sandstone and basalt bedrock of the Lower Miocene and Oligocene age (approximately 24 to 34 million years old) Vaqueros Formation and mudstone and shale of the Oligocene and Eocene age (approximately 29 to 55 million years old) San Lorenzo Formation as shown on Figure B-9. The main trace of the San Andreas fault is about 100, 190, and 260 feet southwest of the classroom, library, and chapel buildings respectively. (See Figure B-2)

### **5.2 Site Description**

The former Alma College campus is within the Bear Creek Redwoods Open Space Preserve near the northeastern base of the central Santa Cruz Mountains, just south of the town of Los Gatos. The site is in an area characterized by very steep topography, with a roughly southeast-northwest trending spur ridge trending through site. Three major structures, the classroom building, library, and chapel, remain atop the spur ridge on a flat area. In addition, several ancillary structures, landscape features and site retaining walls remain in close proximity to these structures. The developed area is accessed by a graded roadway leading to the ridge and along the southwest side of the buildings from Bear Creek Road.

The ground slopes steeply down to the northeast from the ridge to a graded road and to the southwest into a natural drainage feature. Site drainage is characterized as sheet

---

<sup>2</sup> Baker, Jim. Santa Clara County Geologist. Review Comments for Land Use Application, CPO Record No. 18980, 1997.

<sup>3</sup> Questa Engineering Corporation letter dated 26 March 1998 was not provided for our review.

flow down these slopes, with some of the structures having roof-gutters and downspouts that are connected to buried tight-lines that daylight down slope. Most of these drainage provisions are in poor condition and do not appear to be functioning as designed.

### **5.2.1 Classroom Building**

The classroom building is a one- and two-story, wood-framed structure constructed in 1935. The structure is supported on a brick and concrete foundation and is at the western end of the ridge as shown on Figure B-2. Test pit TP-4 was excavated adjacent to the foundation on the southwest side of the building. Based on our observations in the test pit, it appears that the structure is founded on a continuous, concrete, perimeter spread footing embedded 18 inches below the ground surface, gaining support in the underlying sandstone bedrock (see Figure B-6).

### **5.2.2 Library**

The library building, located east of the classroom building, was originally constructed in 1934 as a brick two-story structure. In 1950, a large, two-story concrete addition was constructed at the northwest end of the building. We excavated a designated TP-3 test pit near the north-west corner of the structure to a depth of about 5 feet. The pit revealed the corner of the building to be supported by a deepened footing or concrete caisson extending below the depth of the pit. The bottom of the pit exposed concrete that may be a remnant from a foundation of a prior structure at the site (see Figure B-5). The library appears to be in relatively good shape, however a wooden covered walkway on the northeast side of the building is severely distressed and leaning down slope.

### **5.2.3 Chapel**

The chapel structure was originally constructed in 1909 as a library building as part of the prior Tevis estate that occupied the site prior to the college. The structure is a single-story wooden building, with a deep gable roof. In 1934, the Jesuits who ran Alma College, constructed two side chapels to the building. We excavated a test pit, designated TP-1 along the northeast side of the structure, and observed the structure to be supported on an unreinforced brick foundation bearing in the underlying sandstone bedrock (see Figure B-3). Masonry stairs and flatwork along the eastern corner of the structure appear to be supported by soil or fill, and have been displaced down slope and severely distressed.

### **5.2.4 Site Retaining Walls**

Several large concrete and brick retaining walls are located along the southwest and northeast sides of the ridge, retaining fill placed to widen the building site atop the ridge during prior site development. A concrete wall, up to about 8½ feet tall is located along the southwest side of the graded roadway southwest of the Library building. Test pit TP-5 which was excavated along the back of the wall indicates this wall is trapezoidal in shape, with a base width of about 2 feet, and a 1½-foot tall brick parapet atop the wall. The wall is supported on a 5 foot wide by an approximately 2¾-foot-thick footing embedded in the underlying sandstone bedrock (see Figure B-7). Exposures near the eastern end of the wall where the wall crosses the graded roadway reveal large square rebar within the concrete.

A similar concrete retaining wall with a brick parapet is on the northeast side of the library building. This wall varies from about 14 feet to 20 feet tall plus the parapet. Test pit TP-2 indicates the wall is supported by a 4½ foot wide by 1 foot thick footing also

embedded in the underlying sandstone bedrock (see B-4). The eastern end of this wall was structurally connected to a brick retaining wall located northwest of the old portion of the library building. Large cracks have developed at this location with a separation of several inches between the two walls.

A third large retaining wall, L-shaped and constructed entirely of concrete is located southeast of the chapel uphill of the graded roadway. A shallow test pit, designated TP-6 was excavated on the front of this wall to evaluate whether the site wall foundations extended beyond the front of the wall. The pit exposed no toe on the footing, with the wall embedded about 1 foot below the adjacent ground surface, bearing in sandstone bedrock. This wall is severely cracked and distressed at its corner, and no reinforcing steel was observed in the crack (see Figure B-8).

The walls support fill consisting of stiff, brown to dark brown sandy clay, containing brick, concrete, and glass fragments throughout. No back drain system was observed behind the walls in the test pits.

### **5.3 Groundwater**

We did not encounter evidence of groundwater in our test pits. However, it should be noted that fluctuations in the level of subsurface water could occur due to variations in rainfall, temperature, and other factors not evident at the time these observations were made.

## **6.0 REGIONAL SEISMICITY**

Geologic maps by the California Geological Survey (CGS) and the USGS indicate that traces of the active San Andreas Fault cross the site and large portions of the property area are within an Alquist-Priolo Special Studies fault rupture hazard zone. The main trace of the San Andreas fault is located between about 100 and 260 feet southwest of the subject buildings, as shown on Figure B-2. A subsidiary fault trace identified in the JCA report is located about 45 feet from the library building and crosses beneath the southwestern side of the classroom building as shown on Figure B-2.

The Alquist-Priolo Earthquake Fault Zoning Act (formerly known as the Alquist-Priolo Special Studies Zone Act) was signed into law in California in 1972 to address the potential for geologic hazards associated with fault rupture in the vicinity of new and existing structures. In accordance with this act, earthquake fault zones have been established by the CGS, formerly the California Division of Mines and Geology (CDMG), along known active faults in California. The zones encompass all active<sup>4</sup> or potentially active<sup>5</sup> mapped traces that constitute a potential hazard to structures from surface faulting or fault creep. Based on the proximity of the San Andreas fault to the structures, this area is located within an Alquist-Priolo Special Studies fault rupture hazard zone as shown on Figure B-10; therefore, investigative studies will need to be performed for any new habitable development in this area, in accordance with the requirements described in the Zoning Act.

---

<sup>4</sup> Active faults are defined as those exhibiting either surface ruptures, topographic features created by faulting, surface displacements of geologically Recent (younger than about 11,000 years old) deposits, tectonic creep along fault lines, and/or close proximity to linear concentrations or trends of earthquake epicenters

<sup>5</sup> Potentially active faults are those that have evidence of displacement of deposits of Quaternary age (the last 2 million years).



In addition, the *Map Showing Recently Active Breaks Along the San Andreas Fault Between the Central Santa Cruz Mountains and the Northern Gabilan Range* (Sarna-Wojcicki, Pampeyan, and Hall, 1975) indicates that in 1909 a right-lateral displacement of 0.1 to 0.5 inches was observed along with a right-lateral rotation of a concrete retaining wall in the southeastern portion of the site. This movement may have been related to sympathetic movement on the subsidiary fault during the 1906 earthquake. Furthermore, geomorphic evidence of a faint swale in the northwest portion of the site suggests a trace of the San Andreas Fault crosses the site beneath the existing pond.

The greater San Francisco Bay Area is recognized by geologists and seismologists as one of the most active seismic regions in the United States. The three major faults that pass through the Bay Area in a northwest direction have produced approximately 12 earthquakes per century strong enough to cause structural damage. The faults causing such earthquakes are part of the San Andreas fault system, a major rift in the earth's crust that extends for at least 700 miles along the California Coast, which includes the San Andreas, Hayward, and Calaveras fault zones. These and other faults of the region are shown on Figure B-11. For each of the active faults within 50 kilometers, the distance from the site and estimated mean characteristic Moment magnitude<sup>6</sup> [2007 Working Group on California Earthquake Probabilities (WGCEP) (2007) and Cao et al. (2003)] are summarized in Table 2.

**TABLE 1  
Regional Faults and Seismicity**

<b>Fault Name</b>	<b>Distance (km)</b>	<b>Direction from Site</b>	<b>Mean Characteristic or Maximum Moment Magnitude</b>
San Andreas - 1906 Rupture	0.1	Southwest	7.90
San Andreas - Peninsula	0.1	Southwest	7.15
San Andreas - Santa Cruz Mnts.	0.7	South	7.03
Sargent	7	Southeast	6.80
Monte Vista-Shannon	8	Northeast	6.80
Zayante-Vergeles	11	Southeast	6.80
Hayward - South East Extension	27	East	6.40
Northern San Gregorio	27	West	7.23
Total San Gregorio	27	West	7.44
Monterey Bay-Tularcitos	31	Southwest	7.10
Total Calaveras	31	East	6.93
South Hayward	33	Northeast	6.67
Total Hayward	33	Northeast	6.91
Total Hayward-Rodgers Creek	33	Northeast	7.26
Southern San Gregorio	39	Southwest	6.96

<sup>6</sup> Moment magnitude is an energy-based scale and provides a physically meaningful measure of the size of a faulting event. Moment magnitude is directly related to average slip and fault rupture area.



Figure B-11 also shows the earthquake epicenters for events with magnitude greater than 5.0 from January 1800 through December 2000. Since 1800, four major earthquakes have been recorded on the San Andreas Fault. In 1836, an earthquake with an estimated maximum intensity of VII on the Modified Mercalli (MM) scale (Figure B-12) occurred east of Monterey Bay on the San Andreas Fault (Topozada and Borchartd 1998). The estimated Moment magnitude,  $M_w$ , for this earthquake is about 6.25. In 1838, an earthquake occurred with an estimated intensity of about VIII-IX (MM), corresponding to an  $M_w$  of about 7.5. The San Francisco Earthquake of 1906 caused the most significant damage in the history of the Bay Area in terms of loss of lives and property damage. This earthquake created a surface rupture along the San Andreas Fault from Shelter Cove to San Juan Bautista approximately 430 kilometers in length. It had a maximum intensity of XI (MM), a  $M_w$  of about 7.9, and was felt 560 kilometers away in Oregon, Nevada, and Los Angeles. The most recent earthquake to affect the Bay Area was the Loma Prieta Earthquake of 17 October 1989 with an  $M_w$  of 6.9. The epicenter of the earthquake was in the Santa Cruz Mountains approximately 19 km from the site.

In 1868, an earthquake with an estimated maximum intensity of X on the MM scale occurred on the southern segment (between San Leandro and Fremont) of the Hayward Fault. The estimated  $M_w$  for the earthquake is 7.0. In 1861, an earthquake of unknown magnitude (probably an  $M_w$  of about 6.5) was reported on the Calaveras Fault. The most recent significant earthquake on this fault was the 1984 Morgan Hill earthquake ( $M_w = 6.2$ ).

The 2007 WGCEP at the U.S. Geologic Survey (USGS) predicted a 63 percent chance of a magnitude 6.7 or greater earthquake occurring in the San Francisco Bay Area in 30 years. More specific estimates of the probabilities for different faults in the Bay Area are presented in Table 2.

**TABLE 2**  
**WGCEP (2007) Estimates of 30-Year Probability**  
**of a Magnitude 6.7 or Greater Earthquake**

Fault	Probability (percent)
Hayward-Rodgers Creek	31
N. San Andreas	21
Calaveras	7
San Gregorio	6

**7.0 PRELIMINARY GEOLOGIC CONCLUSIONS**

On the basis of the results of this investigation, we conclude that the proposed rehabilitation of portions of the site are feasible from a geologic and geotechnical standpoint. In our opinion, the primary geologic hazards affecting the site are the potential for fault rupture and strong to very strong seismic shaking, as well as the potential for new shallow landslides to develop on the flanks of the ridge. These and other issues are discussed in the following sub-sections.

### **7.1 Fault Rupture**

As described above in Section 6.0, the site is located within an Alquist-Priolo Special Studies Zone for the San Andreas fault, and as described in Sections 4.0 and 6.0, a subsidiary trace of the San Andreas fault has been identified as crossing beneath the classroom building, as shown on Figure B-2. Based on the site's setting and proximity to this trace and the main trace of the San Andreas fault, we conclude the potential for earthquake-induced ground rupture at the site is high where this trace has been identified, but moderate to low in the areas of the library and chapel. Should new structures be proposed at the site, fault trenches should be excavated to show that these potential building sites are free from active or potentially active faulting. Because of the potential for fault rupture beneath the classroom building, we conclude that this structure should not be reopened for occupancy; however it could be used as a storage facility.

### **7.2 Strong Ground Shaking**

During a major earthquake on one of the active faults in the general region, the site will experience strong to very strong to violent ground shaking. The intensity of the earthquake ground motion at the site will depend upon the characteristics of the generating fault, distance to the earthquake epicenter, magnitude and duration of the earthquake, and specific site geologic conditions. During its history, the site has been subjected to strong ground shaking from moderate to large earthquakes on the Hayward, Calaveras, San Andreas, and other nearby potentially active faults, and future very strong ground shaking should be expected during a major earthquake on these faults.

### **7.3 Earthquake Induced Landslides**

The California Geologic Survey (CGS) has prepared maps titled State of California Seismic Hazard Zones, Los Gatos Quadrangle, dated 23 September 2002 and State of California Seismic Hazard Zones, Castle Rock Ridge Quadrangle, dated 11 August 2005. These maps were prepared in accordance with the Seismic Hazards Mapping Act of 1990. According to the maps, the project site is within a zone described as being prone to earthquake-induced landsliding. Consequently, CGS requires that geotechnical investigation reports within seismic hazard zones comply with the requirements of Special Publication 117 titled Guidelines for Evaluating and Mitigating Seismic Hazard Zones in California, dated 13 March 1997.

Should new structures be proposed for the site, project-specific design level geotechnical investigations should be performed which include detailed subsurface investigations, laboratory testing, and quantitative slope stability analyses to address stability issues in accordance with State Publication SP117.

As described above in Section 5.1, the site is on the large, deep-seated Black Road Landslide. This landslide is one of many similar large-scale, deep-seated landslides located along this portion of the San Andreas fault. These landslides are typically greater than 100 feet deep, and extend down slope to the northeast into Lexington Reservoir or into the Los Gatos Creek Ravine. It is believed that minor displacements occurred on some of these landslides during the 1989 Loma Prieta Earthquake. Generally, movement of these landslides do not manifest in distress at the ground surface, unless structures or hardscape features cross slide-boundaries. We conclude that distress to the site from renewed movement of this landslide during an earthquake would be negligible.

#### **7.4 Cyclic Densification**

During a major earthquake on a segment of one of the nearby faults, strong to very strong shaking is expected to occur at the project site. Strong shaking during an earthquake can result cyclic densification.

Cyclic densification is a phenomenon in which non-saturated, cohesionless soil is densified by earthquake vibrations, causing settlement. Where bedrock is shallow or exposed at the ground surface, we judge the potential for cyclic densification is low. However, a moderate to high potential for cyclic densification exists within the existing retaining wall backfill, which could distress existing or new structural elements supported in these materials. This should be evaluated as part of future studies for any improvements.

#### **7.5 Non-Seismic Ground Failures**

Potential geologic hazards associated with ground failure not caused by earthquakes such as shallow landsliding, expansive soil and collapsible soil, were evaluated and are discussed in this section.

##### **7.5.1 Shallow Landsliding**

Based on our investigation, a shallow small landslide may exist near the northeast corner of the chapel. On the basis of our observations, it appears this slide is shallow and confined to the surficial soils supporting on the slope. The slide may extend uphill beneath the existing stairs located at this end of the building, and appears to be the cause of the distress to these stairs and walkway.

In addition, because of the steep slopes and the soil that blankets the slopes surrounding the developed area, the occurrence of a new shallow landslide within or adjacent to the subject buildings cannot be excluded. A new shallow landslide in this area could be triggered by excessive precipitation. We conclude that a landslide of this nature should not constitute an immediate threat to the integrity of the buildings since they are founded below these materials in the underlying sandstone bedrock. However, new flatwork, walkways or patios founded down slope of the buildings on these soils may be subject to distress from this type of landsliding, and should be evaluated on a case by case basis during a design level geotechnical study for any improvements.

##### **7.5.2 Expansive Soil**

Expansive soil shrinks and swells with changes in moisture content. The clay content, mineralogy, and porosity of the soil also influence the change in volume. The shrinking and swelling caused by expansive clay-rich soil often results in damage to overlying structures. Based on the consistency of the materials encountered in the test pits, we conclude that a low to moderate risk of expansive soil distress exists for structural elements founded on the existing fill. If new concrete flatwork or other structural elements are planned for areas of existing fill, appropriate mitigation measures should be implemented.

The mitigation measures should be determined during the design level geotechnical investigation, but in general may require: 1) the excavation and removal of the expansive soil materials and replacement with non-expansive fill, 2) the placement of a layer of non-expansive fill, which may vary in thickness from 12- to 24- inches, above the expansive soil in areas where concrete flatwork or foundations will be constructed, 3)

moisture conditioning the expansive soil several percent above the optimum moisture content or lime treating the expansive soil, 4) constructing foundations below the zone of seasonal moisture change or capable of withstanding or not being adversely effected by seasonal shrink-swell, and 5) specific control of surface runoff and installation of sub-surface drainage elements, 6) the use of low water demand landscaping, and 7) a combination of any of the above measures.

### **7.5.3 Collapsible Soil**

Soil collapse is the densification of sediments resulting from significant increases in their moisture content. This process typically results from moisture infiltration into the subsurface caused by poor surface drainage, irrigation water or leaking pipes. This phenomenon is more prevalent in low-density, silty, sandy soil deposited in semi-arid and arid climates where the soil has not been subjected to saturation. Based on the relatively shallow depth to bedrock observed over most of the site, and the relative density of the surficial soils observed during our study, we judge the potential for soil collapse at the site to be low.

## **8.0 PRELIMINARY GEOTECHNICAL RECOMMENDATIONS**

We have developed preliminary geotechnical design information to aid in the evaluation of the existing building foundations and site retaining walls.

### **8.1 Foundation Parameters**

The buildings and retaining walls were observed to bear in the underlying sandstone bedrock. For preliminary design purposes, footings bottomed in the sandstone may be evaluated using an allowable bearing pressure of 8,000 pounds per square foot (psf) for dead plus live loads, with a one-third increase for total loads, including wind and/or seismic loads. Footings that may be bottomed in soil or fill may be designed for an allowable bearing pressure 2,000 psf for dead plus live loads, with a one-third increase for total loads, including wind and/or seismic loads. This may be a condition that is present at the northeast corner of the library. Additional investigation may be required in this area to determine if the footings bear on soil or rock.

Lateral load resistance of the footings can be calculated using a combination of passive resistance acting against the vertical faces of the footings and friction along the bases of the footings. Passive resistance may be calculated using lateral pressures corresponding to a uniform pressure of 2,000 pounds per square foot (psf) in the rock. Where soil is present an equivalent fluid weight of 250 pounds per cubic foot (pcf) should be used; the upper foot of rock or soil should be ignored unless confined by a concrete slab or pavement. Frictional resistance should be computed using a base friction coefficient of 0.45. The passive resistance and base friction values include a factor of safety of about 1.5 and may be used in combination without reduction. To utilize the full passive resistance values given above, the bottom edge of footings should be at least seven feet from the face of any slope.

## **8.2 Retaining Wall Design Parameters**

Because no back drains were observed behind the walls and the walls may be subject to hydrostatic pressure, active lateral earth pressure on site retaining walls should be calculated using an equivalent fluid weight of 85 pcf. If new back drains are constructed behind the walls, the walls can be evaluated using an equivalent fluid weight of 35 pcf.

Walls that are restrained from rotation at the top should be designed using at-rest pressures corresponding to an equivalent fluid unit weight of 55 pcf. Where traffic is expected within a distance equal to the height of the walls, the walls should be designed for an additional uniform lateral pressure of 100 psf to be applied over the entire height of the wall or 10 feet, whichever is less.

Because the site is in a seismically active area, the design should be checked for seismic condition, in which the wall pressure is determined by the more critical of the at-rest pressures or seismic pressure increment plus the active earth pressure. The incremental seismic pressure is approximated by a uniform pressure, in psf, of 20 times the height of the wall in feet. This seismic pressure increment is comparable to the 2007 California Building Code Design Earthquake (see Section 8.3). We can provide additional pressure increment values, if a different design level is being considered.

If the existing walls are found to have insufficient lateral resistance, we preliminarily conclude tiebacks could be installed to provide additional lateral resistance. The tiebacks would need to extend into competent soil or rock. Design recommendation for tiebacks, if needed, should be developed as part of a design level investigation.

## **8.3 Seismic Design**

We understand that the buildings will be checked using the Historic Building Code and values are presented in the following subsections. We have also included the 2007 California Building Code values, which include near source effects for your use.

### **8.3.1 Historic Building Code**

We understand the seismic design provisions of the Historic Building Code are based on the 1994 Uniform Building Code (UBC). Therefore, to design in accordance with the UBC requirements for Seismic Zone IV, we recommend a site soil factor of 1.0 be used, corresponding to a Soil Type S1.

### **8.3.2 2007 California Building Code Mapped Values**

For seismic design in accordance with the provisions of 2007 California Building Code (CBC) we recommend the following:

- Maximum Considered Earthquake (MCE)  $S_s$  and  $S_1$  of 2.23g and 1.28g, respectively.
- Site Class B
- Site Coefficients  $F_A$  and  $F_V$  of 1.0 and 1.0

- Maximum Considered Earthquake (MCE) spectral response acceleration parameters at short periods, SMS, and at one-second period, SM1, of 2.23g and 1.28g, respectively.
- Design Earthquake (DE) spectral response acceleration parameters at short period, SDS, and at one-second period, SD1, of 1.49g and 0.85g, respectively.

#### **8.4 Surface Drainage**

Control of surface drainage is critical to the successful rehabilitation of the site. The results of improperly controlled runoff may include foundation heave and/or settlement, erosion, gulying, ponding, and potential shallow slope instability. The design level geotechnical investigation for rehabilitation of existing structures should provide appropriate recommendations to prevent water from ponding in pavement areas and adjacent to the foundation of the structures by sloping the ground surface away from them or by providing area drains. In addition, recommendations should be provided for restoring the roof-gutter systems and for the collection and discharge of collected roof-gutter downspouts, retaining wall back drain outfalls, and area drain outfalls to prevent water from being allowed to discharge freely onto the ground surface adjacent to the buildings or site retaining walls, or to be allowed to flow over the top of any artificial slope.

In our opinion, the collected water from the structures may be discharged on site utilizing properly designed energy dissipaters located down slope of the structures and/or improvements in areas to be determined by the project geotechnical engineer. We conclude that if the drainage systems are properly designed, they should effectively mitigate future development of springs, seeps, or shallow surface landsliding of the soil mantling the slopes in the immediate vicinity of the structures.

#### **9.0 LIMITATIONS**

The findings and preliminary conclusions and recommendations presented in this letter report apply only to the portion of the Alma College property as described, and are the result of limited geologic and engineering studies and our interpretations of the existing geological and geotechnical conditions at the time of our field activities. The conclusions and recommendations contained in this letter are preliminary and should be used to evaluate the viability of reoccupying the site. A detailed geotechnical investigation should be performed to develop design geotechnical recommendations and design plans for any specific mitigation measures or foundation improvements. We have prepared this report for the exclusive use of our client in substantial accordance with the generally accepted geological engineering practice as it exists in the area at the time of our study. No warranty is expressed or implied.



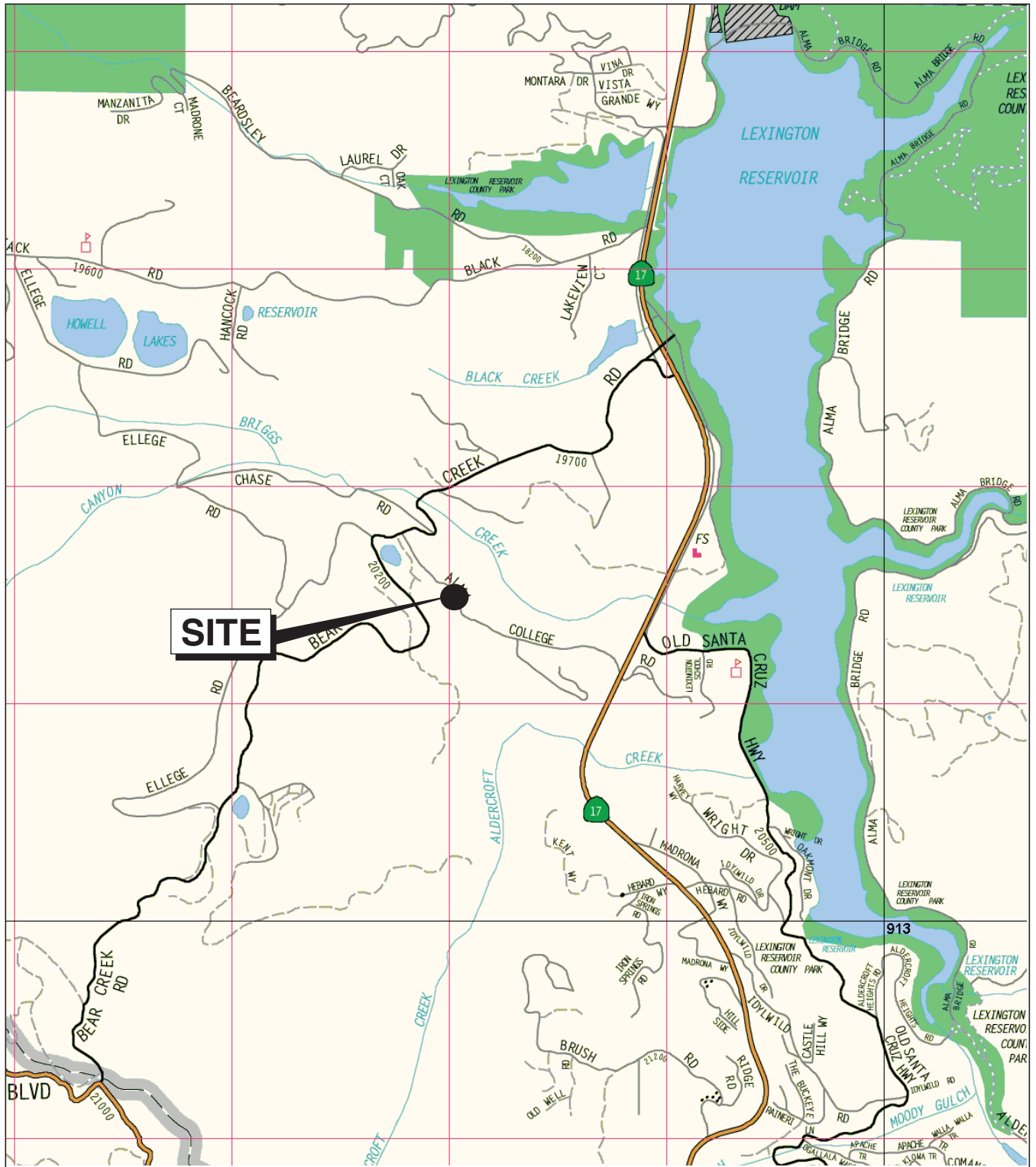

Base map: The Thomas Guide  
 Santa Clara County  
 1999

0 1/4 1/2 Mile

Approximate scale



**ALMA COLLEGE CONDITIONS ASSESSMENT**  
 Santa Clara County, California

**SITE LOCATION MAP**

**Treadwell&Rollo**

Date 10/05/09

Project No. 4986.01

Figure B-1





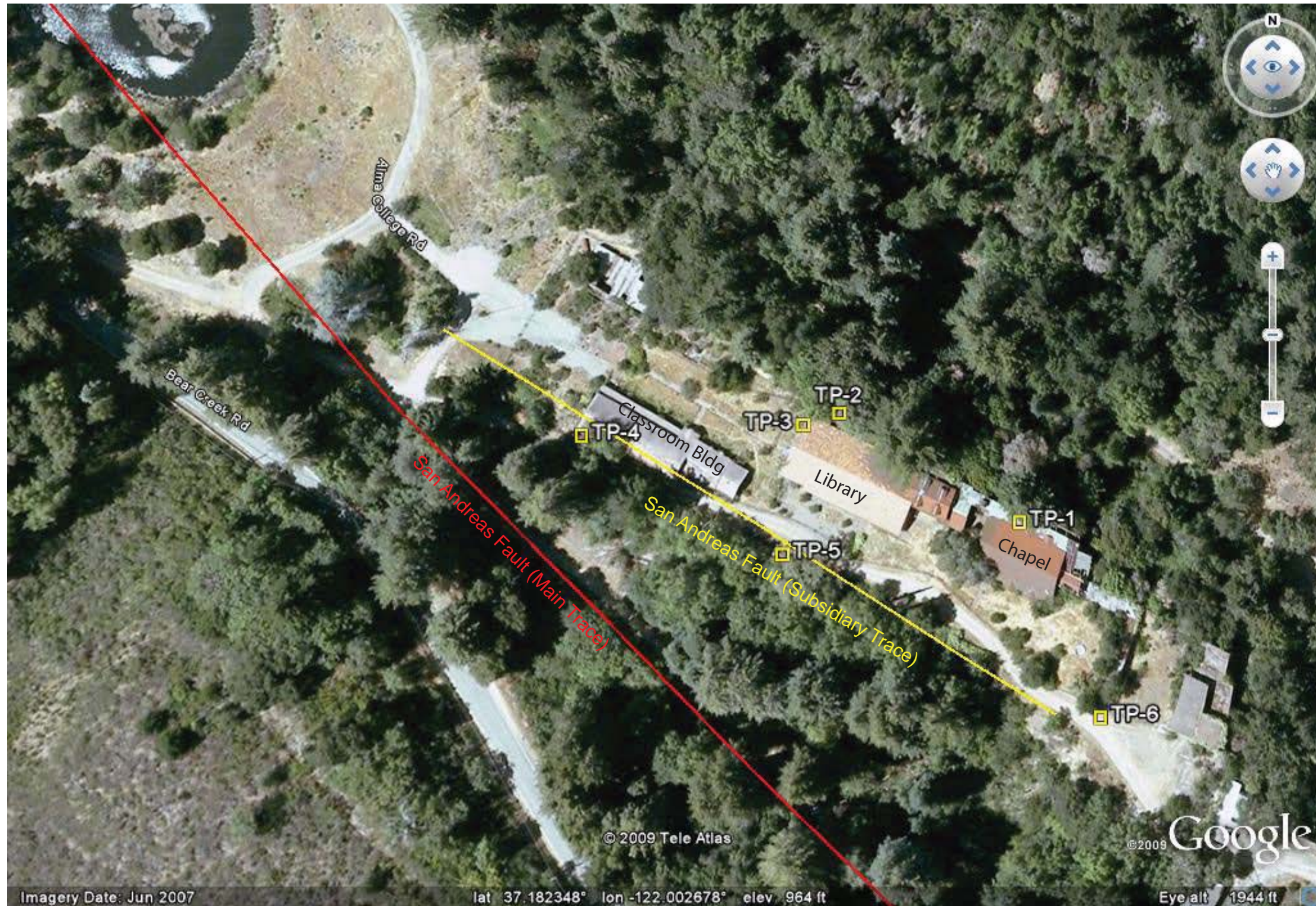

Not To Scale

<b>ALMA COLLEGE CONDITIONS ASSESSMENT</b> Santa Clara County, California		
<b>PARTIAL SITE PLAN</b>		
Date 08/19/09	Project No. 4986.01	Figure B-2
<b>Treadwell&amp;Rollo</b>		





**SECTION A-A'**

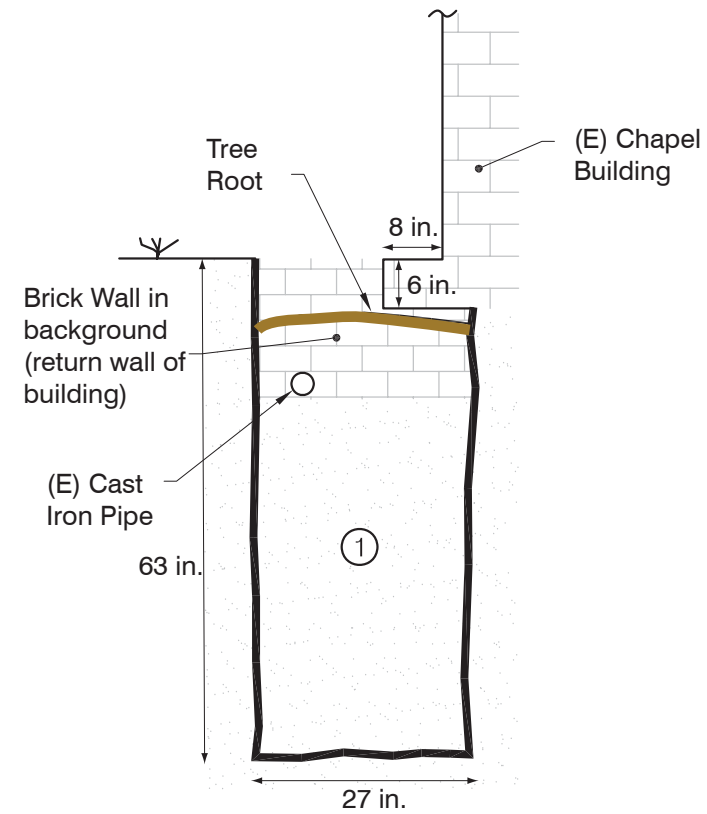

**PLAN VIEW**

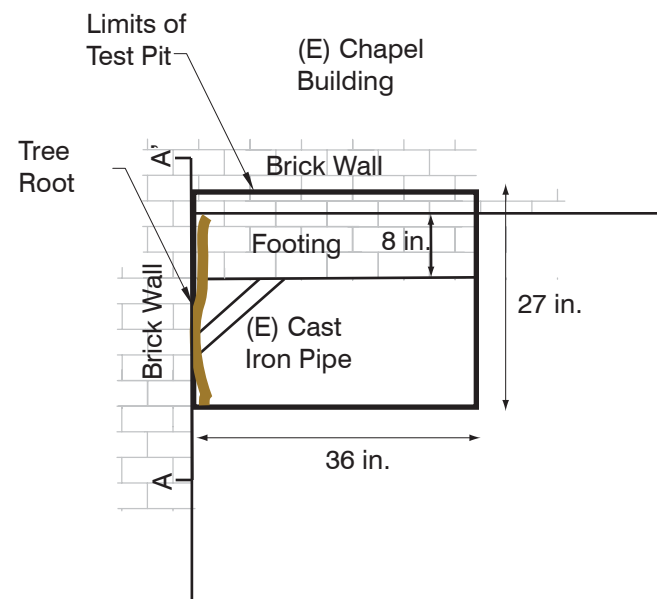

**PHOTO**



- ① SANDSTONE  
yellowish brown (10YR 5/6) and  
grayish brown (10YR 5/2),  
homogeneous, dense, friable,  
well-sorted, fine- to very fine-  
grained, subrounded, slightly  
moist  
[BEDROCK]

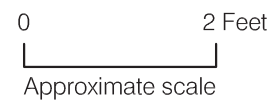

**ALMA COLLEGE CONDITIONS ASSESSMENT**  
Santa Clara County, California

**LOG OF TEST PIT  
TP-1**

Date 08/19/09 | Project No. 4986.01 | Figure B-3

**Treadwell&Rollo**

**SECTION B-B'**

**PLAN VIEW**

**PHOTOS**

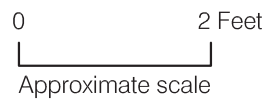
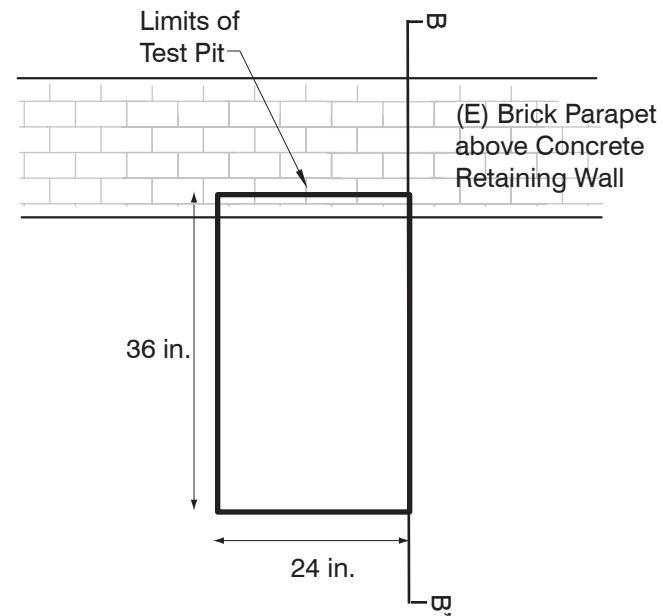
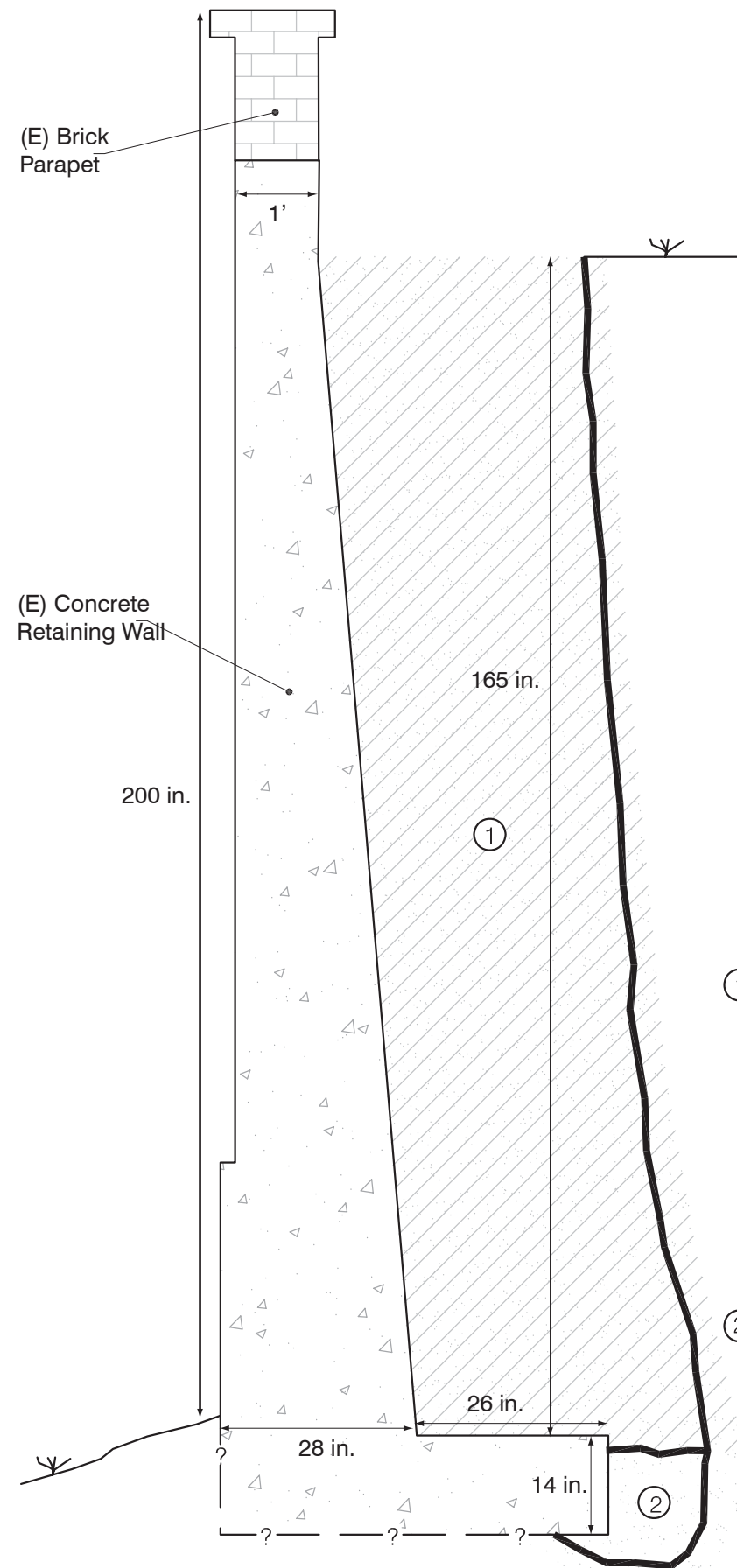

- ① SANDY CLAY (CL)  
brown (10YR 4/3) to dark brown (10YR 3/3), stiff, slightly moist, low to moderately plastic, heterogeneous with brick, concrete, and glass fragments scattered throughout, 10-20% fine- to medium-grained sand and 5-10% gravel [RETAINING WALL BACKFILL]
- ② SANDSTONE  
yellowish brown (10YR 5/6) and grayish brown (10YR 5/2), homogeneous, dense, friable, well-sorted, fine- to very fine-grained, subrounded, slightly moist [BEDROCK]



**ALMA COLLEGE CONDITIONS ASSESSMENT**  
Santa Clara County, California

**LOG OF TEST PIT**  
**TP-2**

Date 08/19/09 | Project No. 4986.01 | Figure B-4

**Treadwell&Rollo**

**SECTION C-C'**

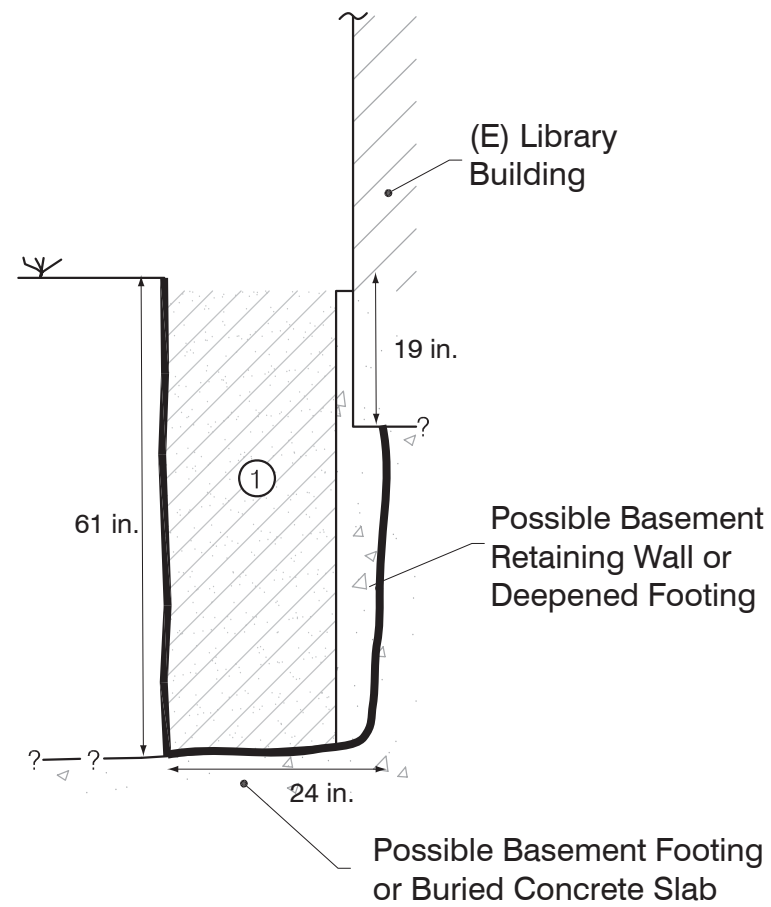

**PLAN VIEW**

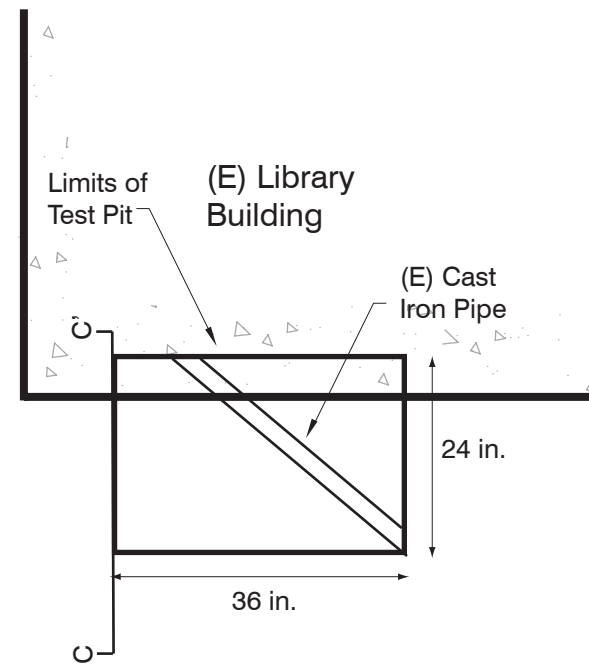

**PHOTOS**



- ① SILTY SAND (SM) to CLAYEY SAND (SC) very dark grayish brown (10YR 3/2) with variegated colored sand and rock fragments, medium dense, poorly sorted, very fine- to coarse-grained, scattered brick and concrete fragments, moist, low plasticity, abundant roots and rootlets  
[FILL]

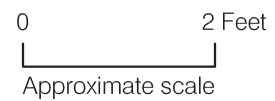

**ALMA COLLEGE CONDITIONS ASSESSMENT**  
Santa Clara County, California

**LOG OF TEST PIT**  
**TP-3**

Date 08/19/09 | Project No. 4986.01 | Figure B-5

**Treadwell&Rollo**



**SECTION D-D'**

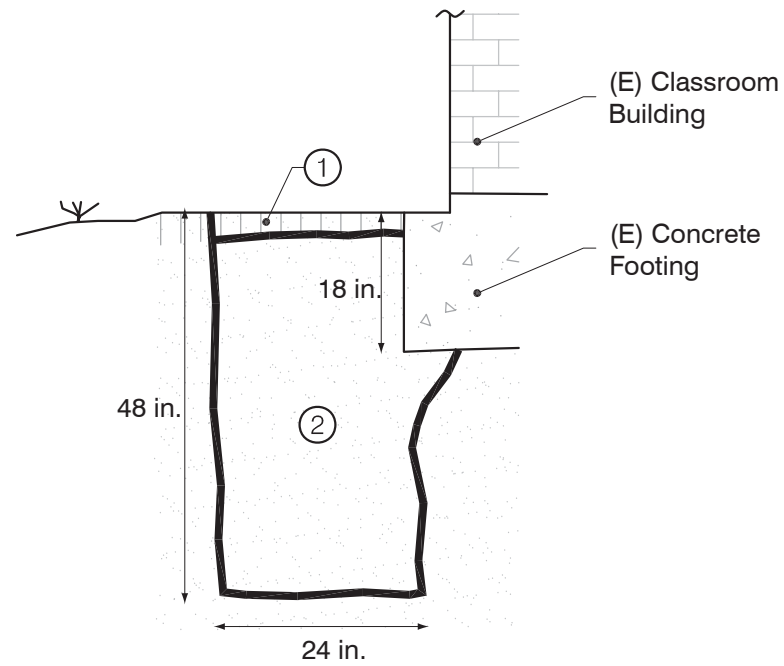

**PLAN VIEW**

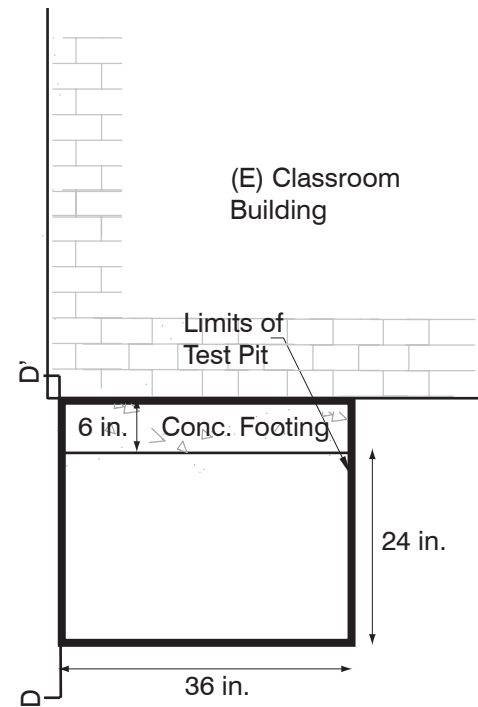

**PHOTO**



- ① SANDY SILT (ML)  
dark grayish brown (10YR 4/2),  
stiff, homogeneous, dry, poorly  
sorted, fine- to coarse grained,  
dry, abundant roots and organics  
[TOPSOIL]
- ② SANDSTONE  
yellowish brown (10YR 5/6) to  
grayish brown (10YR 5/2),  
very dense, homogeneous, well-  
sorted, very fine- to fine-grained,  
subrounded to subangular,  
slightly moist  
[BEDROCK]

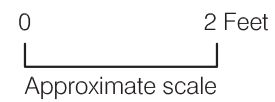

**ALMA COLLEGE CONDITIONS ASSESSMENT**  
Santa Clara County, California

**LOG OF TEST PIT  
TP-4**

Date 08/19/09 | Project No. 4986.01 | Figure B-6

**Treadwell&Rollo**

**SECTION E-E'**

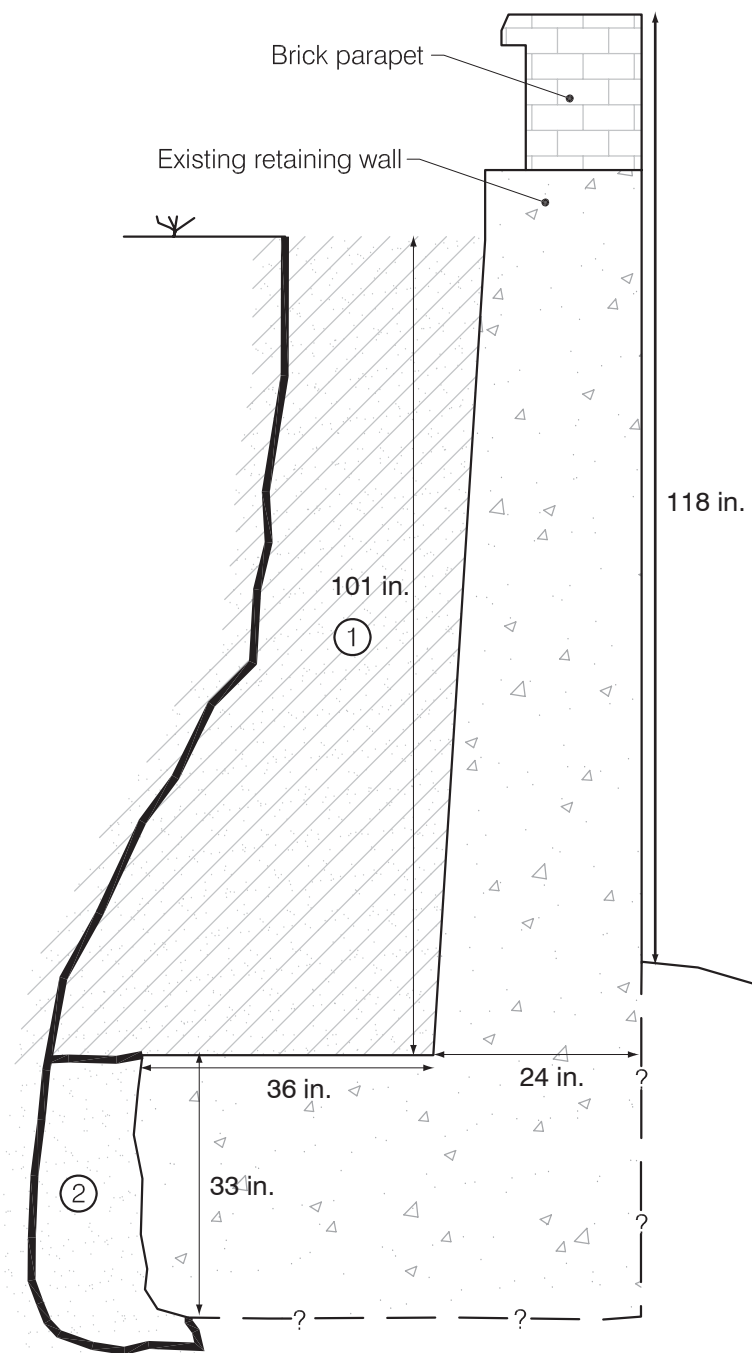

**PLAN VIEW**

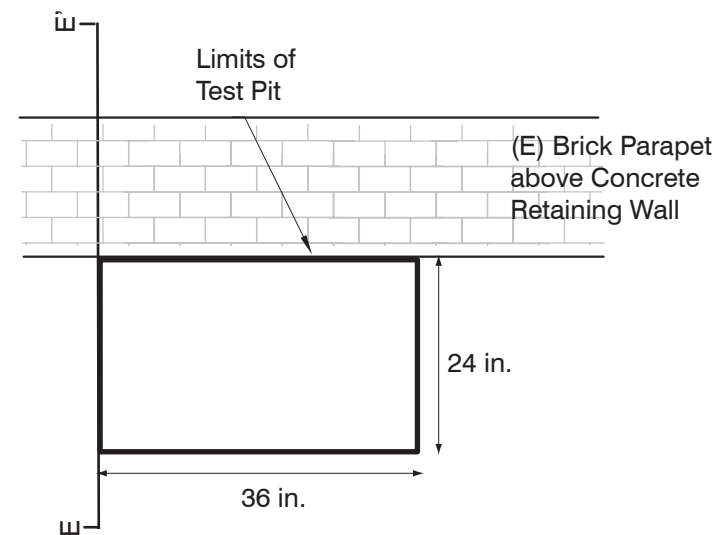

**PHOTOS**



- ① SANDY CLAY (CL)  
brown (10YR 4/3) to dark brown (10YR 3/3), stiff, slightly moist, low to moderately plastic, heterogeneous with brick, concrete, and glass fragments scattered throughout, 10-20% fine- to medium-grained sand and 5-10% gravel [RETAINING WALL BACKFILL]
- ② SANDSTONE  
yellowish brown (10YR 5/6) and grayish brown (10YR 5/2), homogeneous, dense, friable, well-sorted, fine- to very fine-grained, subrounded, slightly moist [BEDROCK]

**ALMA COLLEGE CONDITIONS ASSESSMENT**  
Santa Clara County, California

**LOG OF TEST PIT**  
**TP-5**

Date 08/19/09 | Project No. 4986.01 | Figure B-7

**Treadwell&Rollo**

**SECTION F-F'**

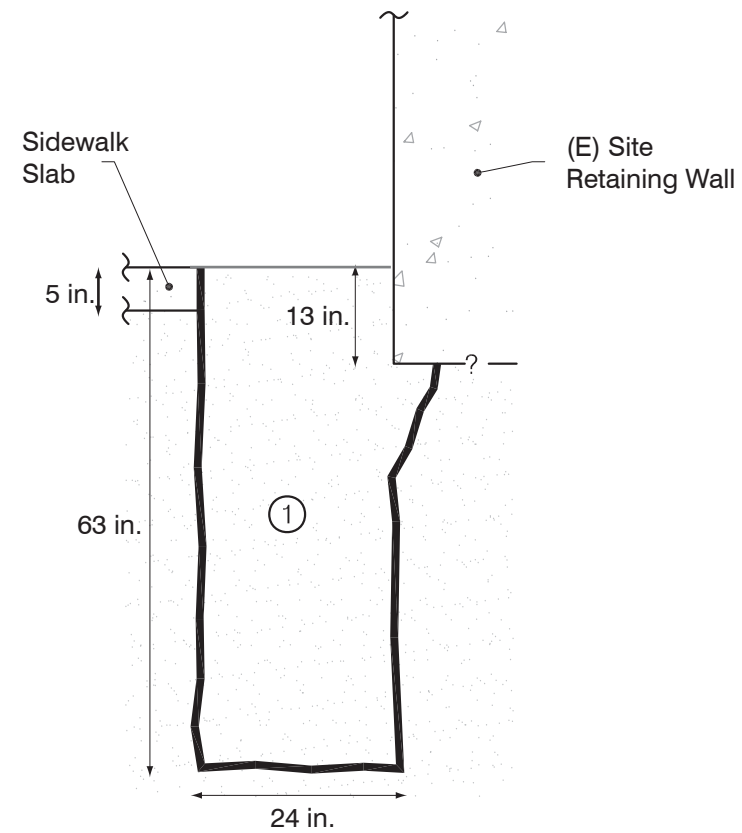

- ① SANDSTONE  
yellowish brown (10YR 5/6) and  
grayish brown (10YR 5/2),  
homogeneous, dense, friable,  
well-sorted, fine- to very fine-  
grained, subrounded, slightly  
moist  
[BEDROCK]

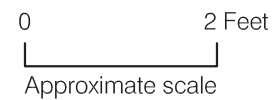

**PLAN VIEW**

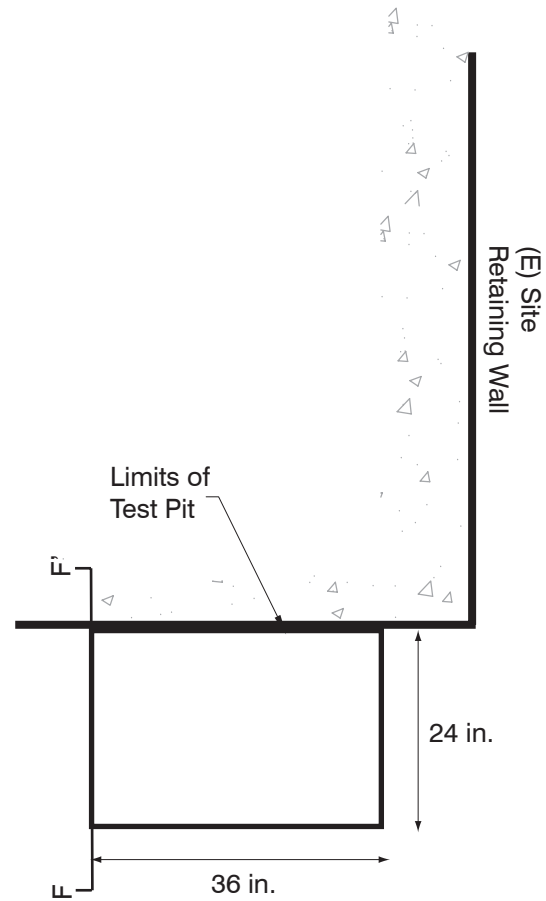

**PHOTOS**



**ALMA COLLEGE CONDITIONS ASSESSMENT**  
Santa Clara County, California

**LOG OF TEST PIT**  
**TP-6**

Date 08/19/09 | Project No. 4986.01 | Figure B-8

**Treadwell&Rollo**



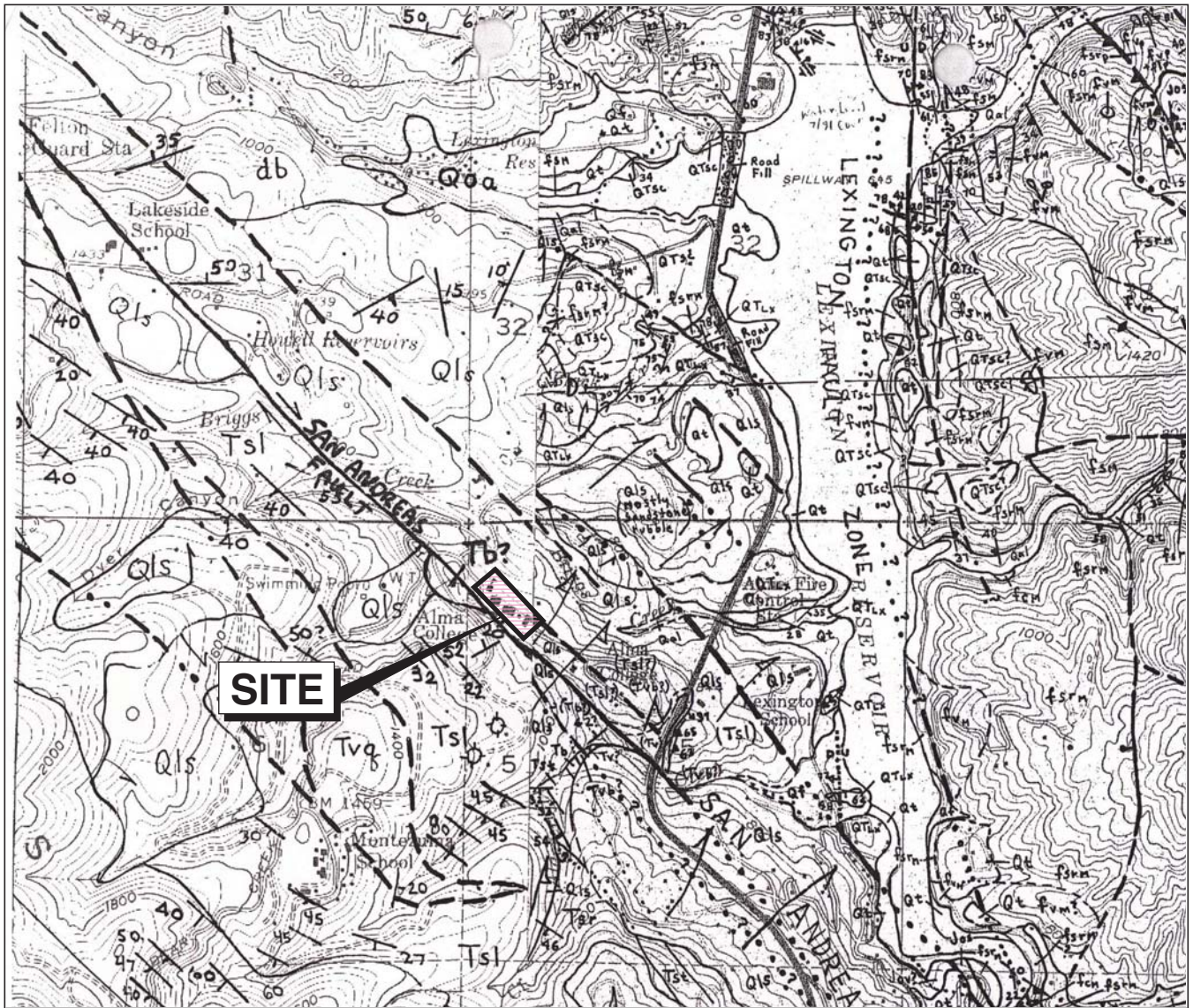

**EXPLANATION**

Qal – Alluvium

Qls – Landslide Deposits

Tv and Tvq – Vaqueros Formation sandstone

Tsl – San Lorenzo Formation shale and mudstone

Tst – Twohard Shale member of the San Lorenzo Formation

Tb – Butano Formation Sandstone



Geologic contact



Fault (dashed where approximate, dotted where concealed)



Landslide (arrows indicate primary direction of movement)



Syncline



Anticline



Strike and Dip of Bedding

Reference:

BRABB, E. E. and T. W. DIBBLE, Jr., 1979, Preliminary Geologic Map of Castle Rock Ridge Quadrangle, Santa Cruz and Santa Clara Counties, California, U.S. Geological Survey, Open File Report 79-659, 1:24,000.

McLAUGHLIN, R. J., J. C. CLARK, E. E. BRABB, AND E. J. HELLEY, 1991, Geologic Map and Structure Sections of the Los Gatos 7 1/2-Minute Quadrangle, Santa Clara and Santa Cruz Counties, California, U. S. Geological Survey, Open-File Map 91-593, 1:24,000.

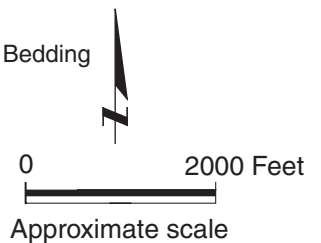

**ALMA COLLEGE CONDITIONS ASSESSMENT**  
Santa Clara County, California

**REGIONAL GEOLOGIC MAP**

**Treadwell & Rolo**

Date 10/05/09

Project No. 4986.01

Figure B-9



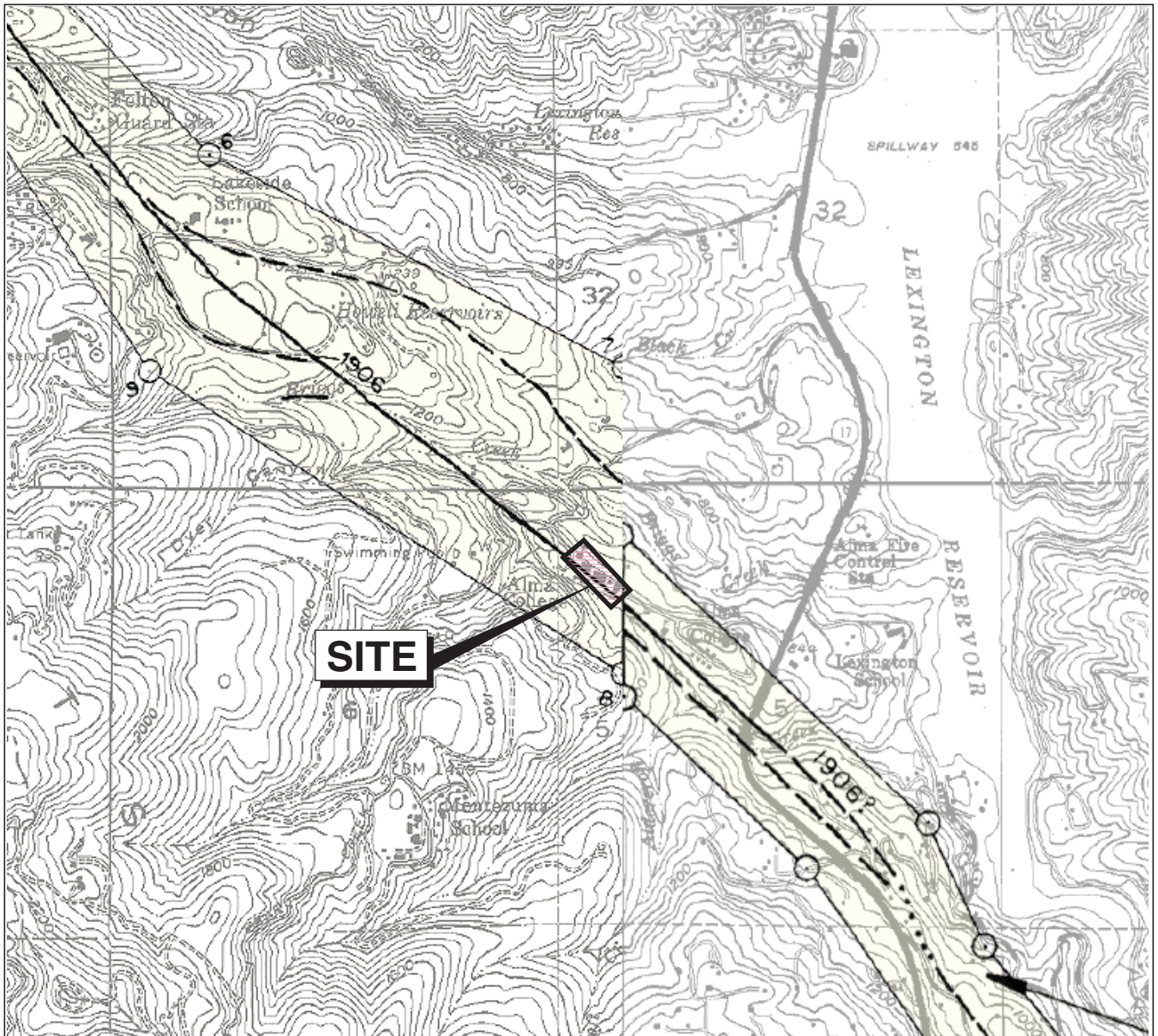

**EXPLANATION**

**Potentially Active Faults**

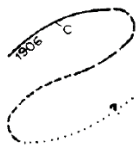

Faults considered to have been active during Quaternary time; solid line where accurately located, long dash where approximately located, short dash where inferred, dotted where concealed; query (?) indicates additional uncertainty. Evidence of historic offset indicated by year of earthquake-associated event or C for displacement caused by creep or possible creep.

----- Aerial photo lineaments (not field checked); based on youthful geomorphic and other features believed to be the results of Quaternary faulting.

**Special Studies Zone Boundaries**

3-----4 These are delineated as straight-line segments that connect consecutively numbered turning points so as to define one or more special studies zone segments.

-----1 Seaward projection of zone boundary.

Reference:  
State of California Special Studies Zones for Los Gatos and  
Castlerock Ridge Quadrangles, 1991 and 1974 respectively.



0 2000 Feet  
Approximate scale

**ALMA COLLEGE CONDITIONS ASSESSMENT**  
Santa Clara County, California

**REGIONAL ALQUIST-PRIOLO MAP**

**Treadwell & Rollo**

Date 10/05/09

Project No. 4986.01

Figure B-10

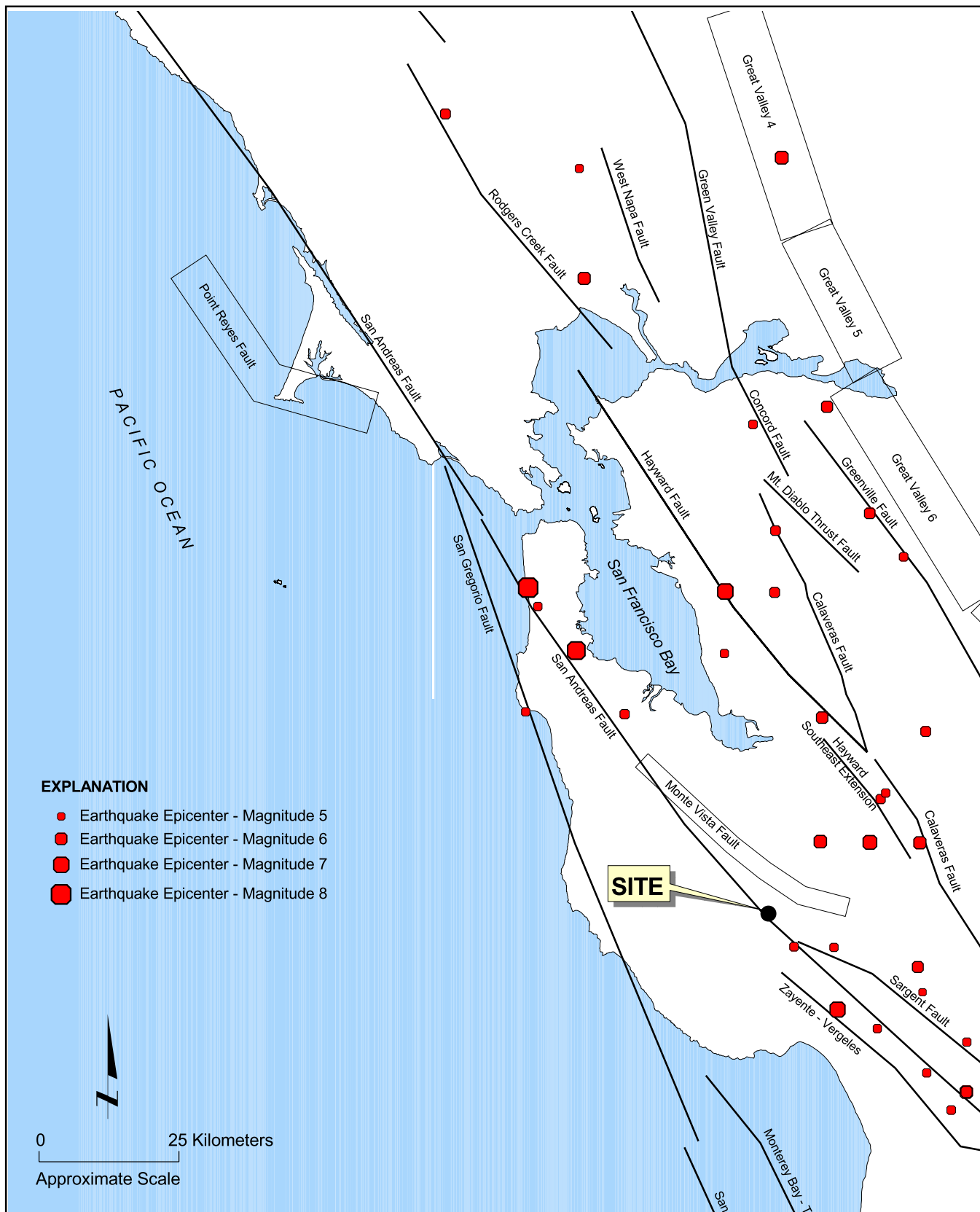

**EXPLANATION**

- Earthquake Epicenter - Magnitude 5
- Earthquake Epicenter - Magnitude 6
- Earthquake Epicenter - Magnitude 7
- Earthquake Epicenter - Magnitude 8

**NOTES:**

Digitized data for fault coordinates and earthquake catalog was developed by the California Department of Conservation Division of Mines and Geology. The historic earthquake catalog includes events from January 1800 to December 2000.

**ALMA COLLEGE CONDITIONS ASSESSMENT**  
Santa Clara County California

**MAP OF MAJOR FAULTS AND EARTHQUAKE EPICENTERS IN THE SAN FRANCISCO BAY AREA**

**Treadwell&Rollo**

Date: 10/05/09 | Project No. 4986.01 | Figure B-11

<p><b>I Not felt by people, except under especially favorable circumstances. However, dizziness or nausea may be experienced.</b> Sometimes birds and animals are uneasy or disturbed. Trees, structures, liquids, bodies of water may sway gently, and doors may swing very slowly.</p> <p><b>II Felt indoors by a few people, especially on upper floors of multi-story buildings, and by sensitive or nervous persons.</b> As in Grade I, birds and animals are disturbed, and trees, structures, liquids and bodies of water may sway. Hanging objects swing, especially if they are delicately suspended.</p> <p><b>III Felt indoors by several people, usually as a rapid vibration that may not be recognized as an earthquake at first. Vibration is similar to that of a light, or lightly loaded trucks, or heavy trucks some distance away. Duration may be estimated in some cases.</b> Movements may be appreciable on upper levels of tall structures. Standing motor cars may rock slightly.</p> <p><b>IV Felt indoors by many, outdoors by a few. Awakens a few individuals, particularly light sleepers, but frightens no one except those apprehensive from previous experience. Vibration like that due to passing of heavy, or heavily loaded trucks. Sensation like a heavy body striking building, or the falling of heavy objects inside.</b> Dishes, windows and doors rattle; glassware and crockery clink and clash. Walls and house frames creak, especially if intensity is in the upper range of this grade. Hanging objects often swing. Liquids in open vessels are disturbed slightly. Stationary automobiles rock noticeably.</p> <p><b>V Felt indoors by practically everyone, outdoors by most people. Direction can often be estimated by those outdoors. Awakens many, or most sleepers. Frightens a few people, with slight excitement; some persons run outdoors.</b> Buildings tremble throughout. Dishes and glassware break to some extent. Windows crack in some cases, but not generally. Vases and small or unstable objects overturn in many instances, and a few fall. Hanging objects and doors swing generally or considerably. Pictures knock against walls, or swing out of place. Doors and shutters open or close abruptly. Pendulum clocks stop, or run fast or slow. Small objects move, and furnishings may shift to a slight extent. Small amounts of liquids spill from well-filled open containers. Trees and bushes shake slightly.</p> <p><b>VI Felt by everyone, indoors and outdoors. Awakens all sleepers. Frightens many people; general excitement, and some persons run outdoors.</b> Persons move unsteadily. Trees and bushes shake slightly to moderately. Liquids are set in strong motion. Small bells in churches and schools ring. Poorly built buildings may be damaged. Plaster falls in small amounts. Other plaster cracks somewhat. Many dishes and glasses, and a few windows break. Knickknacks, books and pictures fall. Furniture overturns in many instances. Heavy furnishings move.</p> <p><b>VII Frightens everyone. General alarm, and everyone runs outdoors.</b> People find it difficult to stand. Persons driving cars notice shaking. Trees and bushes shake moderately to strongly. Waves form on ponds, lakes and streams. Water is muddied. Gravel or sand stream banks cave in. Large church bells ring. Suspended objects quiver. Damage is negligible in buildings of good design and construction; slight to moderate in well-built ordinary buildings; considerable in poorly built or badly designed buildings, adobe houses, old walls (especially where laid up without mortar), spires, etc. Plaster and some stucco fall. Many windows and some furniture break. Loosened brickwork and tiles shake down. Weak chimneys break at the roofline. Cornices fall from towers and high buildings. Bricks and stones are dislodged. Heavy furniture overturns. Concrete irrigation ditches are considerably damaged.</p> <p><b>VIII General fright, and alarm approaches panic.</b> Persons driving cars are disturbed. Trees shake strongly, and branches and trunks break off (especially palm trees). Sand and mud erupts in small amounts. Flow of springs and wells is temporarily and sometimes permanently changed. Dry wells renew flow. Temperatures of spring and well waters varies. Damage slight in brick structures built especially to withstand earthquakes; considerable in ordinary substantial buildings, with some partial collapse; heavy in some wooden houses, with some tumbling down. Panel walls break away in frame structures. Decayed pilings break off. Walls fall. Solid stone walls crack and break seriously. Wet grounds and steep slopes crack to some extent. Chimneys, columns, monuments and factory stacks and towers twist and fall. Very heavy furniture moves conspicuously or overturns.</p> <p><b>IX Panic is general.</b> Ground cracks conspicuously. Damage is considerable in masonry structures built especially to withstand earthquakes; great in other masonry buildings - some collapse in large part. Some wood frame houses built especially to withstand earthquakes are thrown out of plumb, others are shifted wholly off foundations. Reservoirs are seriously damaged and underground pipes sometimes break.</p> <p><b>X Panic is general.</b> Ground, especially when loose and wet, cracks up to widths of several inches; fissures up to a yard in width run parallel to canal and stream banks. Landsliding is considerable from river banks and steep coasts. Sand and mud shifts horizontally on beaches and flat land. Water level changes in wells. Water is thrown on banks of canals, lakes, rivers, etc. Dams, dikes, embankments are seriously damaged. Well-built wooden structures and bridges are severely damaged, and some collapse. Dangerous cracks develop in excellent brick walls. Most masonry and frame structures, and their foundations are destroyed. Railroad rails bend slightly. Pipe lines buried in earth tear apart or are crushed endwise. Open cracks and broad wavy folds open in cement pavements and asphalt road surfaces.</p> <p><b>XI Panic is general.</b> Disturbances in ground are many and widespread, varying with the ground material. Broad fissures, earth slumps, and land slips develop in soft, wet ground. Water charged with sand and mud is ejected in large amounts. Sea waves of significant magnitude may develop. Damage is severe to wood frame structures, especially near shock centers, great to dams, dikes and embankments, even at long distances. Few if any masonry structures remain standing. Supporting piers or pillars of large, well-built bridges are wrecked. Wooden bridges that "give" are less affected. Railroad rails bend greatly and some thrust endwise. Pipe lines buried in earth are put completely out of service.</p> <p><b>XII Panic is general.</b> Damage is total, and practically all works of construction are damaged greatly or destroyed. Disturbances in the ground are great and varied, and numerous shearing cracks develop. Landslides, rock falls, and slumps in river banks are numerous and extensive. Large rock masses are wrenched loose and torn off. Fault slips develop in firm rock, and horizontal and vertical offset displacements are notable. Water channels, both surface and underground, are disturbed and modified greatly. Lakes are dammed, new waterfalls are produced, rivers are deflected, etc. Surface waves are seen on ground surfaces. Lines of sight and level are distorted. Objects are thrown upward into the air.</p>
---

<p><b>ALMA COLLEGE CONDITIONS ASSESSMENT</b> Santa Clara County, California</p>	<p><b>MODIFIED MERCALLI INTENSITY SCALE</b></p>		
<p><b>Treadwell &amp; Rollo</b></p>	<p>Date 10/05/09</p>	<p>Project No. 4986.01</p>	<p>Figure B-12</p>

**II. ASSESSMENTS & ANALYSES**  
**SECTION C - STRUCTURAL ASSESSMENT**

- Figure C-1. Chapel: New Shear Walls Proposed
- Figure C-2. 1950 Library Addition: Window Infill Proposed
- Figure C-3. Classroom: New Shear Walls & Hardy Frames Proposed





---

**II. ASSESSMENTS & ANALYSES**  
**SECTION C - STRUCTURAL ASSESSMENT**

---

**CHAPEL BUILDING****1.0 CHAPEL BUILDING - EXISTING CONDITIONS****1.1 *General Structural Description***

The existing Chapel building is a one-story over crawlspace wood-framed structure. There is also a one-story below grade wood-framed portion (assumed to be added in 1934, when the side chapels were added to the Chapel building) which is below the exterior walkway to the north of the main structure. This portion was not investigated in detail.

The structural system for the Chapel building consists of the following:

- 2 layers of 1 x straight sheathing at the roof and asphalt shingles.
- The roof sheathing is supported by a two-way system of 3x6 exposed roof rafters spaced at 4 feet to 5 feet on center each way.
- The roof rafters are supported by heavy timber, exposed and clad, roof trusses at approximately 10 feet on center spanning approximately 45 feet.
- Exterior stud bearing walls are 2x6 studs at 16 inches on center.
- The ground floor framing system over crawlspace consists of finished wood flooring over 1x diagonal sheathing (where exposed to view). Flooring is supported by 3x12 floor joists at 16 inches on center. Floor joists span between the exterior foundation walls and interior wood girders on support posts.
- The interior girder and post line in the crawlspace is supported on unreinforced brick masonry pier footings. The continuous exterior foundation walls are constructed of unreinforced brick masonry of 8 inches thickness, plus a brick veneer course, for a total thickness of 13 inches.
- Lateral (wind or seismic) loads are resisted primarily by the exterior and interior wood sheathing on the exterior stud walls. The existing 1x roof sheathing and the existing 1x diagonal sheathing and finished flooring at the floor level act as diaphragms to transfer the lateral loads to the exterior walls, which are then transferred to the existing foundations.
- Based on our limited walkthrough observations, the main structure of the Chapel appears to be in fair to good condition and appears to have performed well over its life, including in past earthquake events. Only minor evidence of foundation cracking or settlements or variations in floor levelness was noted during our site visits.
- The exceptions noted were the lack of proper site drainage around the building, the need for additional crawlspace and lower level venting, areas of deterioration and dry rot damage at the roof eaves and at the exterior porch roof framing/trellis and settling and movement of adjacent site retaining walls and site access structures.

**1.2 *Foundations***

The existing interior post pier footings and perimeter foundations are of unreinforced brick masonry construction. No independent field testing of the brick shear strength was possible within the scope of this report. These foundations, including the interior post

piers, where observed, appear to have performed adequately over their life. Although unreinforced brick masonry foundations are acceptable under the 2007 California Historic Building Code if evaluated for their existing loading conditions, in our opinion, the existing foundations will likely require strengthening or replacement. This is addressed in more detail under the *Code Considerations* section below.

### **1.3 Wall Structure**

The existing interior and exterior wood stud walls appear to be in good condition, including the interior wood panel finishes. The north and south exterior walls were noted to be deflected outward at the top likely due to the outward thrust of the roof trusses. Seismic deficiencies noted in the existing walls and their connections to the floor and roof diaphragms are addressed under the *Code Considerations* section below.

### **1.4 Roof Structure**

The existing roof framing, except at the exterior, exposed rafter ends and at roof diaphragm edges exposed to weather, appeared to be in good condition, with little evidence of interior moisture/leaks or dry rot damage. A more detailed survey would be required to confirm this. Based on our preliminary analysis to date, the roof structure appears to be adequate to support the tributary dead and code live loads, with the exception being the existing joint connections of the heavy timber roof truss members, which would likely require strengthening. A more detailed analysis would be required to confirm this. Any seismic deficiencies noted in the existing roof diaphragm and its connections are addressed under the *Code Considerations* section below.

### **1.5 Floor Structure**

Only limited access to observe the crawlspace framing was possible during our site visits. Review of additional photographs provided to us indicated that the crawlspace framing, in the areas photographed, is in fair to good condition. A more detailed survey would be required to confirm this.

### **1.6 Code Considerations**

General Note: As we understand it, structural evaluation of a qualified historic building would be required by the California Historical Building Code (CHBC) for a proposed change of use or occupancy. In addition, local regulatory agencies may also have more specific requirements for historic buildings. For qualified historic buildings, the CHBC provides alternative measures to that of the regular code for new construction. The CHBC does provide latitude in evaluating historic construction and requires a minimum level of structural performance. Unsafe conditions identified must be corrected by alternative resistance or strengthening. Our preliminary analysis indicated that there are several structural deficiencies that would be prudent to address on a voluntary basis if the building, vacant now, is proposed to be reoccupied in the future.

A preliminary seismic analysis of the Chapel building, not including the portion under the north exterior walkway, was completed based on known structural information. This analysis was based on the lateral load regulations of Section 8-706 of the 2007 California Historic Building Code, including Tables 8-8-A and 8-8-B, allowable capacities for existing materials. The seismic lateral force level for evaluation of historic buildings required by this code section is equivalent to approximately 75% of the 1995 California Building Code (1994 Uniform Building Code) seismic force level for new buildings.



## **2.0 CHAPEL BUILDING - STRUCTURAL DEFICIENCIES**

The structural deficiencies noted are summarized below. The proposed strengthening to address these deficiencies is covered in the Treatment Recommendations section.

### **2.1 Roof Diaphragm Capacity**

The existing 1x skip sheathing does not have adequate capacity to transfer the code required wind or seismic forces to the interior and exterior shear walls or to brace the walls out-of-plane. In addition, the connections of the roof diaphragm to the interior and exterior shear walls are likely deficient.

### **2.2 Floor Diaphragm Capacity**

The existing 1x diagonal sheathing and finish wood flooring has adequate capacity to transfer the code required wind or seismic forces to the existing interior and exterior shear walls. However, the connections of the floor diaphragm to these walls are likely deficient.

### **2.3 Existing Shear Wall Capacities**

A detailed survey of the existing exterior wall sheathing was not possible during this phase. However, in general, the existing exterior wood sheathing and interior wood paneling do not have adequate capacity to resist the code required wind or seismic forces. In addition, the exterior walls are not connected (bolted) to the existing foundations to transfer the code required wind or seismic forces.

### **2.4 Existing Foundations**

A detailed analysis was not possible without some additional brick shear strength testing. However, based on our experience and engineering judgment, the existing unreinforced brick masonry foundations do not likely have adequate capacity to resist their tributary code required dead, live and wind or seismic forces without additional strengthening or replacement.

### **2.5 Additional Noted Deficiencies**

In addition to the deficiencies noted above, the following deficiencies/maintenance issues were noted but not reviewed in detail:

- More crawlspace vents will likely be required.
- The exterior North Walkway extends from the east end of Chapel building to the west end of the 1950 Library structure. The North Walkway roof overlaps the roofs of the adjacent buildings. Portions, if not all, of the North Walkway posts, roof framing/trellis will need to be stabilized/strengthened, replaced, or could be removed.
- The existing one-story below grade portion of the Chapel building north of the main building was not reviewed in detail. It is possible that this portion could be demolished and backfilled depending on its historic significance and the proposed future use of the site. As a minimum, if this portion is to be retained, the existing deck finish would likely need to be removed and replaced in order to repair any water damage/dry rot in this area and in order to properly waterproof the structure below the porch deck.

- The existing brick and concrete site retaining wall north of the Chapel building, which the Chapel building relies on to retain the soil under its north foundations, has settled, rotated and deflected significantly. This is addressed in more detail under Site Retaining Walls later in this section.
- The existing exterior brick and concrete stairs which provide access to the lower level of the building under the north porch deck, have settled and failed and will need to be removed (and replaced) if the lower level is to be retained.

### **3.0 CHAPEL BUILDING - TREATMENT RECOMMENDATIONS**

#### **3.1 *Protect Foundations and Crawlspace Framing***

- Provide proper grading to direct site water, including roof runoff, away from existing or new foundations.
- Provide overall site and foundation drainage to keep site water away from the existing infiltration and accumulation in the crawlspaces.
- Provide proper, code required, wood-earth separation between the existing or new exterior wall sill plates and crawlspace framing and adjacent soil grades.

#### **3.2 *Roof Diaphragm Strengthening***

- Improve roof diaphragm capacity by the addition of new 5/8" plywood sheathing throughout over the existing 1x skip sheathing. Improve roof diaphragm connections to the existing exterior walls, including new, proposed shear walls noted below, by the addition of new plywood edge nailing to existing blocking over walls and new Simpson framing clips to attach the blocking to the existing exterior wall top plates.

#### **3.3 *Improve Floor Diaphragm to Foundation Connections***

- Provide additional Simpson framing clips and anchor plates (or bolts) to improve the connection of the existing floor diaphragms to existing or new blocking and the connection of the foundation sill plates to the existing (or new) foundations.

#### **3.4 *Improve Existing Shear wall Strength***

- Provide new plywood sheathing on the exterior face of selected exterior walls (see Figure C-1) and new foundation bolting, including new Simpson hold-downs, to existing (or new) foundations to improve overall building seismic resistance.

#### **3.5 *Improve Roof Truss Connections***

- Investigate and strengthen existing truss member joint connections by the addition of new bolts and gusset plates at the truss member intersections.

#### **3.6 *Improve Foundations***

- Investigate and strengthen or replace existing unreinforced brick masonry foundations with new reinforced concrete.

## **LIBRARY BUILDING**

The existing Library building consists of the original one-story Library structure, assumed to be constructed in 1934, and the new two-story Library structure addition, constructed in 1950. The original drawings for the 1950 Library addition, which combined both architectural and structural information (12 sheets total), were provided for our use.

### **1.0 1934 LIBRARY STRUCTURE - EXISTING CONDITIONS**

#### **1.1 General Structural Description**

The structural system for the 1934 Library structure consists of the following:

- 1x straight sheathing (assumed) at the roof with asphalt shingles.
- The roof sheathing is supported by wood roof rafters at approximately 24 inches on center (assumed; the roof framing, except for rafter tails, was not exposed at the time of our site visits).
- The wood roof rafters appear to be supported by interior concrete beams (extent of reinforcing unknown).
- The ground floor is a concrete slab-on-grade.
- The exterior walls consist of approximate 5-inch thick concrete walls (extent of reinforcing unknown) with exterior 8-inch thick brick veneer at the lower level and a wood shingle exterior wall finish at the upper level.
- The exterior wall foundations appear to be of concrete construction with an exterior brick veneer course (the extent of reinforcing and thickness of the foundation walls are unknown).
- Lateral (wind or seismic) loads are resisted primarily by the exterior concrete walls. The existing 1x roof sheathing acts as a diaphragm to transfer the lateral loads to the exterior walls and their foundations.
- The 1934 Library building appears to be in fair to good condition and appears to have performed well over its life, including in past earthquake events. Only minor evidence of foundation cracking or settlements or variations in floor levelness was noted during our site visits.
- The exceptions noted were the lack of proper site drainage around the building, areas of deterioration and dry rot damage at the roof eaves and at the exterior porch roof framing/trellis and settling and movement of adjacent site retaining walls.

#### **1.2 Foundations**

The existing exterior perimeter foundations are of concrete construction. No independent field testing or investigation of the concrete strength or the extent, if any, of existing reinforcing steel in the concrete was possible within the scope of this report. These foundations, where observed, appear to have performed adequately over their life. This is addressed in more detail under the *Code Considerations* section below.

#### **1.3 Wall Structure**

The existing exterior concrete walls appear to be in good condition. Seismic deficiencies noted in the existing walls and their connections to the roof diaphragm are addressed under the *Code Considerations* section below.

#### **1.4 Roof Structure**

The existing roof framing, except at the exterior, exposed rafter ends and at roof diaphragm edges exposed to weather, is assumed to be in fair to good condition, with little evidence of interior moisture/leaks or dry rot damage. A more detailed survey would be required to confirm this. It was not possible within the scope of this phase of the project to provide a preliminary analysis to verify if the roof structure is adequate to support the tributary dead and code live loads, or if it would require strengthening. A more detailed analysis, including exposing a portion of the existing roof framing, would be required to confirm this. Any seismic deficiencies noted in the existing roof diaphragm and its connections are addressed under the *Code Considerations* section below.

#### **1.5 Code Considerations**

See General Note in *Chapel Building Code Consideration* section.

A preliminary seismic analysis of the 1934 Library addition building was completed based on known structural information. This analysis was based on the lateral load regulations of Section 8-706 of the 2007 California Historic Building Code, including Tables 8-8-A and 8-8-B, allowable capacities for existing materials. The seismic lateral force level for evaluation of historic buildings required by this code section is equivalent to approximately 75% of the 1995 California Building Code (1994 Uniform Building Code) seismic force level for new buildings.

### **2.0 1934 LIBRARY STRUCTURE - STRUCTURAL DEFICIENCIES**

The structural deficiencies noted are summarized below. The proposed strengthening to address these deficiencies is covered in the Treatment Recommendations section.

#### **2.1 Roof Diaphragm Capacity**

The existing 1x skip sheathing does not have adequate capacity to transfer the code required wind or seismic forces to the exterior shear walls or to brace the exterior walls out-of-plane. In addition, the connections of the roof diaphragm to the exterior shear walls are likely deficient.

#### **2.2 Existing Shear wall Capacities**

A detailed survey of the existing exterior concrete walls, including an investigation of the concrete strength or the extent, if any, of existing reinforcing steel in the concrete, was not possible within the scope of this report. The existing concrete walls are not adequately connected to the existing roof framing to transfer the code required wind or seismic forces.

#### **2.3 Brick Veneer/Wood Wall Anchorage**

The existing brick veneer and wood wall finishes on the exterior walls are not likely adequately anchored to the exterior concrete walls. A more detailed survey would be required to confirm this.

### **3.0 1934 LIBRARY STRUCTURE - TREATMENT RECOMMENDATIONS**

#### **3.1 Protect Foundations and Crawlspace Framing**

- Provide proper grading and site drainage to direct site water, including roof runoff, away from the existing foundations.

**3.2 Roof Diaphragm Strengthening**

- Improve roof diaphragm capacity by the addition of new 5/8" plywood sheathing throughout over the existing 1x skip sheathing. Improve roof diaphragm connections to the existing exterior walls by the addition of new plywood edge nailing to existing or new blocking over the exterior walls and new Simpson framing clips to attach the blocking to the exterior wall existing or new sill plate. Bolt existing or new sill plates to top of existing exterior concrete walls with new epoxy bolts. Provide new out-of-plane wall bracing consisting of horizontal threaded rods epoxied into the top of the concrete walls and strapped to existing roof framing or new blocking.

**3.3 Improve Existing Shear wall Strength**

- Investigate and strengthen, if required, the existing exterior concrete shear walls. A possible alternative would be to tie the 1934 Library structure to the 1950 Library structure in the east-west direction to resist its tributary seismic loads.

**3.4 Improve Exterior Wall Brick Veneer and Wood Wall Anchorage**

- Investigate and strengthen the anchorage of the existing lower level brick veneer and upper level wood wall finishes to the existing exterior concrete walls.

## 1.0 1950 LIBRARY STRUCTURE - EXISTING CONDITIONS

### 1.1 *General Structural Description*

The structural system for the 1950 Library structure addition consists of the following:

- 3-inch lightweight concrete slab at the roof and clay tile shingles.
- The roof slab is supported by 8-inch WF steel beams at approximately 6 feet on center which span to and are supported by 16-inch WF steel girder and column gabled frames at 19 feet 4 inches on center.
- Exterior bearing walls are of reinforced concrete; 8 inches thick above the ground floor and 10 inches thick below the ground floor.
- The ground floor slab over the basement is 11 inches thick, reinforced concrete supported by interior reinforced concrete columns and the exterior reinforced concrete bearing walls.
- The basement floor slab is a 6-inch thick reinforced concrete slab-on-grade.
- The existing foundations consist of reinforced concrete interior spread footings and exterior grade beams.
- Based on our limited walkthrough observations, the main structure of the 1950 Library addition appears to have performed well over its life, including in past earthquake events. Only minor evidence of foundation cracking or settlements was noted during our site visits.
- The exceptions noted were cracking in the exterior non-structural columns along the south arcade, evidence of water damage to the ground floor ceiling (roof) finishes at various locations indicating possible roof leaks, and some settling and rotation of the north site retaining wall adjacent to the building.

### 1.2 *Foundations*

The existing interior column spread footings and exterior wall grade beam foundations are of reinforced concrete construction. Field sampling and testing to verify existing concrete strengths was not possible as part of this phase of the project. Based on our preliminary analysis, in general, the foundations appear to be adequately reinforced and to have performed well over the life of the structure. Our preliminary calculations, however, indicate bearing pressures that are somewhat higher than would be expected for the existing site soil conditions. A more detailed analysis would be required to confirm this.

### 1.3 *Wall Structure*

The existing exterior reinforced concrete walls appear to be in good condition and to have performed well over their life. Seismic deficiencies noted in the existing walls and their connections to the floor and roof diaphragms are addressed under the *Code Considerations* section below.

### 1.4 *Roof Structure*

The existing roof framing was not exposed for observation at the time of our site visits. Some deterioration (rusting) of the roof steel framing and cracking of the roof concrete slab may be occurring due to moisture infiltration. There was evidence of water damage to various areas of the existing ground floor ceilings noted during our site visits which is likely due to roof leaks. A more detailed survey would be required to confirm this. Based on our preliminary analysis to date, the existing roof structure appears to be adequate to support the tributary dead and code live loads. A more detailed analysis would be required to confirm this. Any seismic deficiencies noted in the existing roof diaphragm

and its connections to the exterior walls are addressed under the *Code Considerations* section below.

### **1.5 Floor Structure**

The existing ground floor reinforced concrete flat slab appeared to be in good condition, with little evidence of cracking or significant floor deflections. Based on our preliminary analysis, the existing floor structure appears to be adequate to support the tributary dead and code live loads. A more detailed analysis, based on a specific future use or occupancy, would be required to confirm this.

### **1.6 Code Considerations**

See General Note in *Chapel Building Code Considerations* section.

A preliminary seismic analysis of the 1950 Library addition building was completed based on known structural information. This analysis was based on the lateral load regulations of Section 8-706 of the 2007 California Historic Building Code, including Tables 8-8-A and 8-8-B, allowable capacities for existing materials. The seismic lateral force level for evaluation of historic buildings required by this code section is equivalent to approximately 75% of the 1995 California Building Code (1994 Uniform Building Code) seismic force level for new buildings.

## **2.0 1950 LIBRARY STRUCTURE - STRUCTURAL DEFICIENCIES**

The structural deficiencies noted are summarized below. The proposed strengthening to address these deficiencies is covered in the Treatment Recommendations section.

### **2.1 Roof Diaphragm Capacity**

Based on our preliminary analysis, the existing lightweight concrete roof slab appears to have adequate capacity to transfer the code required wind or seismic forces. However, its connections to the perimeter concrete shear walls, for both in-plane and out-of-plane loading, and to the interior steel frames appear to be deficient. This will require removal and replacement of the existing roofing likely around the entire perimeter and at selective interior locations. However, due to the roof leaks noted in several locations, removal and replacement of all the existing roofing would be prudent, in our opinion.

### **2.2 Existing Shear wall Capacities:**

Based on our preliminary analysis, in general, the existing reinforced concrete exterior walls appear to be of sufficient length and to be adequately reinforced for the code required wind or seismic forces. However, one section of the north exterior wall in the northwest corner of the building below the ground floor, has existing door and window openings at the existing bathrooms that does not allow for the proper transfer of seismic loads from the solid wall panel above the openings to the foundations below.

### **2.3 Additional Noted Deficiencies:**

In addition to the deficiencies noted above, the following deficiencies/maintenance issues were noted but not reviewed in detail.

- Some existing non-structural concrete columns along the south exterior arcade are cracked and spalled.



**3.0 1950 LIBRARY STRUCTURE - TREATMENT RECOMMENDATIONS****3.1 *Protect Foundations***

- Provide proper grading and site drainage to direct site water, including roof runoff, away from the existing foundations.

**3.2 *Improve Roof Diaphragm Connections***

- Provide additional anchorage of the exterior concrete walls to the roof diaphragm. Strengthen connections of the roof diaphragm to the existing steel interior frames.

**3.3 *Improve Roofing/Waterproofing***

- Remove and replace existing clay tiles and investigate and repair existing roofing waterproofing system to minimize future moisture infiltration.

**3.4 *Improve Existing Shear wall Strength***

- Improve existing exterior reinforced concrete shear wall capacities by infilling opening in a portion of north exterior wall at the northwest corner of the building. (See Figure C-2).

**3.5 *Repair Cracked Arcade Columns***

- Repair by epoxy injection or replace existing cracked and spalled non-structural concrete columns along south exterior arcade.



## **CLASSROOM BUILDING**

### **1.0 CLASSROOM BUILDING - EXISTING CONDITIONS**

#### **1.1 General Structural Description**

The existing Classroom building is a one-story over crawlspace wood-framed structure with concrete foundations, assumed to have been constructed in approximately 1935.

The structural system for the Classroom building consists of the following:

- 1x skip sheathing at the roof and asphalt shingles.
- The roof sheathing is supported by “carpenter built” trusses at 32” on center consisting of 2x4 roof rafters, 2x6 ceiling joists and 1x6 diagonal members nailed together at the member intersections.
- The roof framing spans the full width of the building and is supported on the exterior stud bearing walls which appear to be typically 2x6 studs at 16 inches on center.
- The ground floor framing system over crawlspace consists of 1x straight sheathing overlain by 1x finish flooring. Access to the crawlspace was not possible during our site visits. The framing is assumed to consist of 2x floor joists at 16 inches on center. Floor joists are assumed to span between the exterior foundation walls and interior wood girders on support posts.
- The interior girder and post lines in the crawlspace are assumed to be supported on unreinforced concrete pier footings. The continuous exterior foundations and foundation walls are of concrete construction, assumed to be unreinforced, with a single Wythe brick veneer.
- Lateral (wind or seismic) loads are resisted primarily by the exterior wood sheathing and interior plaster and wood paneling finishes on the exterior stud walls. The existing 1x roof sheathing and the existing 1x straight sheathing and finished flooring at the floor level act as diaphragms to transfer the lateral loads to the exterior walls, which are then transferred to the existing exterior foundations.
- Based on our limited walkthrough observations, the main structure of the Classroom building appears to be in fair condition and appears to have performed well over its life, including in past earthquake events.
- The exceptions noted were the lack of proper site drainage around the building, the need for additional crawlspace venting, significant areas of deterioration and dry rot damage at the main roof, the main roof eaves and the exterior porch roof and eaves. In addition, the existing main roof appears to be sagging in several locations, indicating that the roof members are overloaded and require strengthening.

#### **1.2 Foundations**

The existing foundations (where exposed) are of concrete construction, likely unreinforced. No independent field testing to verify the concrete compressive strength and the extent of reinforcing steel, if any, was possible within the scope of this report. These foundations, where observed, appear to have performed adequately over their life. Any seismic deficiencies noted in the existing foundations are addressed under the *Code Considerations* section below.

### **1.3 Wall Structure**

The existing interior and exterior wood stud walls appear to be in fair to good condition with the exception being some areas of the interior finishes on the exterior walls where there is evidence of moisture infiltration and possible water damage. A more detailed survey would be required to confirm the extent of this damage. Seismic deficiencies noted in the existing walls and their connections to the floor and roof diaphragms are addressed under the *Code Considerations* section below.

### **1.4 Roof Structure**

The existing roof framing, except at exposed rafter ends and at roof diaphragm edges exposed to weather, appeared to be in fair to good condition. However, based on our preliminary analysis to date, the roof “trusses” and their connections are inadequate to support the roof dead and code required live loads without additional strengthening. This deficiency is addressed in more detail in the Treatment Recommendations section. Seismic deficiencies noted in the existing roof diaphragm and its connections are addressed under the *Code Considerations* section below.

### **1.5 Floor Structure**

Access to observe the crawlspace framing was not possible during our site visits. Any seismic deficiencies noted in the existing floor diaphragm and its connections are addressed under the *Code Considerations* section below.

### **1.6 Code Considerations**

See General Note in *Chapel Building Code Considerations* section.

A preliminary seismic analysis of the Classroom building was completed based on known structural information. This analysis was based on the lateral load regulations of Section 8-706 of the 2007 California Historic Building Code, including Tables 8-8-A and 8-8-B, allowable capacities for existing materials. The seismic lateral force level for evaluation of historic buildings required by this code section is equivalent to approximately 75% of the 1995 California Building Code (1994 Uniform Building Code) seismic force level for new buildings.

## **2.0 CLASSROOM BUILDING - STRUCTURAL DEFICIENCIES**

The structural deficiencies noted are summarized below. The proposed strengthening to address these deficiencies is covered in the Treatment Recommendations section.

### **2.1 Roof Diaphragm Capacity**

The existing 1x skip sheathing does not have adequate capacity to transfer the code required wind or seismic forces to the interior and exterior shear walls or to brace the walls out-of-plane. In addition, the connections of the roof diaphragm to the interior and exterior shear walls are likely deficient.

### **2.2 Floor Diaphragm Capacity:**

The existing 1x sheathing and finish wood flooring has adequate capacity to transfer the code required wind or seismic forces to the existing interior and exterior shear walls. However, the connections of the floor diaphragm to these walls are likely deficient.

### **2.3 Existing Shear wall Capacities**

A detailed survey of the existing exterior wall sheathing was not possible during this phase. However, in general, the existing exterior wood sheathing and interior plaster or wood paneling finishes do not have adequate capacity to resist the code required wind or seismic forces. The south exterior wall, in particular, is very open with many window and door openings. In addition, the exterior walls are not adequately connected (bolted) to the existing foundations to transfer the code required wind or seismic forces.

### **2.4 Existing Foundations**

A detailed analysis was not possible without some additional concrete strength testing and verification of the extent of reinforcing steel, if any. However, based on our experience and engineering judgment, the existing concrete foundations likely have adequate capacity to resist their tributary dead and code required live loads without additional strengthening. However, localized strengthening or possible new foundation portions will likely be required in areas where new exterior shear walls are proposed.

### **2.5 Additional Noted Deficiencies**

In addition to the deficiencies noted above, the following deficiencies/maintenance issues were noted but not reviewed in detail:

- More crawlspace vents will likely be required.
- Portions of the existing roof, roof rafter tails and exterior porch roof framing will need to be stabilized/strengthened or replaced.

## **3.0 CLASSROOM BUILDING - TREATMENT RECOMMENDATIONS**

### **3.1 Protect Foundations and Crawlspace Framing**

- Provide proper grading to direct site water, including roof runoff, away from existing or new foundations.
- Provide overall site and foundation drainage to keep site water away from the existing infiltration and accumulation in the crawlspaces.
- Provide proper, code required, wood-earth separation between the existing or new exterior wall sill plates and crawlspace framing and adjacent soil grades.

### **3.2 Roof Framing Strengthening**

- Strengthen existing roof framing “trusses” throughout by sistering (doubling up) with roof rafters, ceiling joists and diagonals at all roof members and by improving the connections of all existing and new vertical and diagonal members to all existing and new roof rafters and ceiling joists.

### **3.3 Roof Diaphragm Strengthening:**

- Improve roof diaphragm capacity by the addition of new 5/8” plywood sheathing throughout over the existing 1x skip sheathing. Improve roof diaphragm connections to the existing exterior walls, including new, proposed shear walls noted below, by the addition of new plywood edge nailing to existing blocking over walls and new Simpson framing clips to attach the blocking to the existing exterior wall top plates.

**3.4 Improve Floor Diaphragm to Foundation Connections:**

- Provide additional Simpson framing clips and anchor plates (or bolts) to improve the connection of the existing floor diaphragms to existing or new blocking and the connection of the foundation sill plates to the existing (or new) foundations.

**3.5 Improve Existing Shear wall Strength:**

- Provide new plywood sheathing on the interior face of selected exterior walls and on selected interior walls. In addition, provide new Simpson Strong Walls or Hardy Frames at selected locations in the south exterior walls (see Figure C-3) and new foundation bolting, including new Simpson hold-downs, to existing (or new) foundations to improve overall building seismic resistance.

**3.6 Improve Existing Foundations:**

- Investigate and provide localized strengthening (new reinforced concrete) of existing concrete foundations, if required, in areas where new exterior plywood shear walls are proposed above.

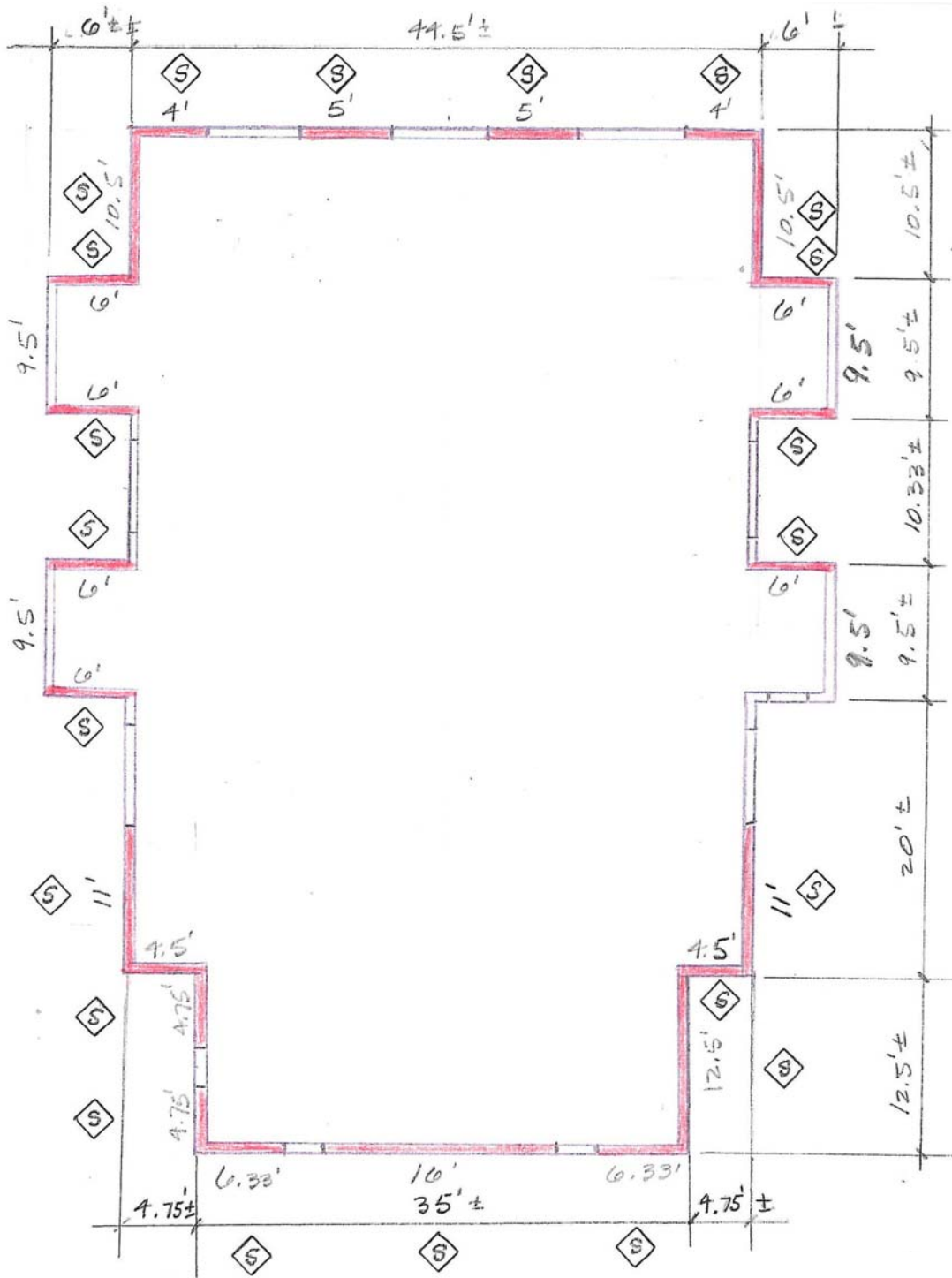

Legend for Shear Strengthening

Plywood shear walls

### Chapel

Structural Treatment Recommendation:

New plywood applied to existing walls proposed for shear wall strengthening.

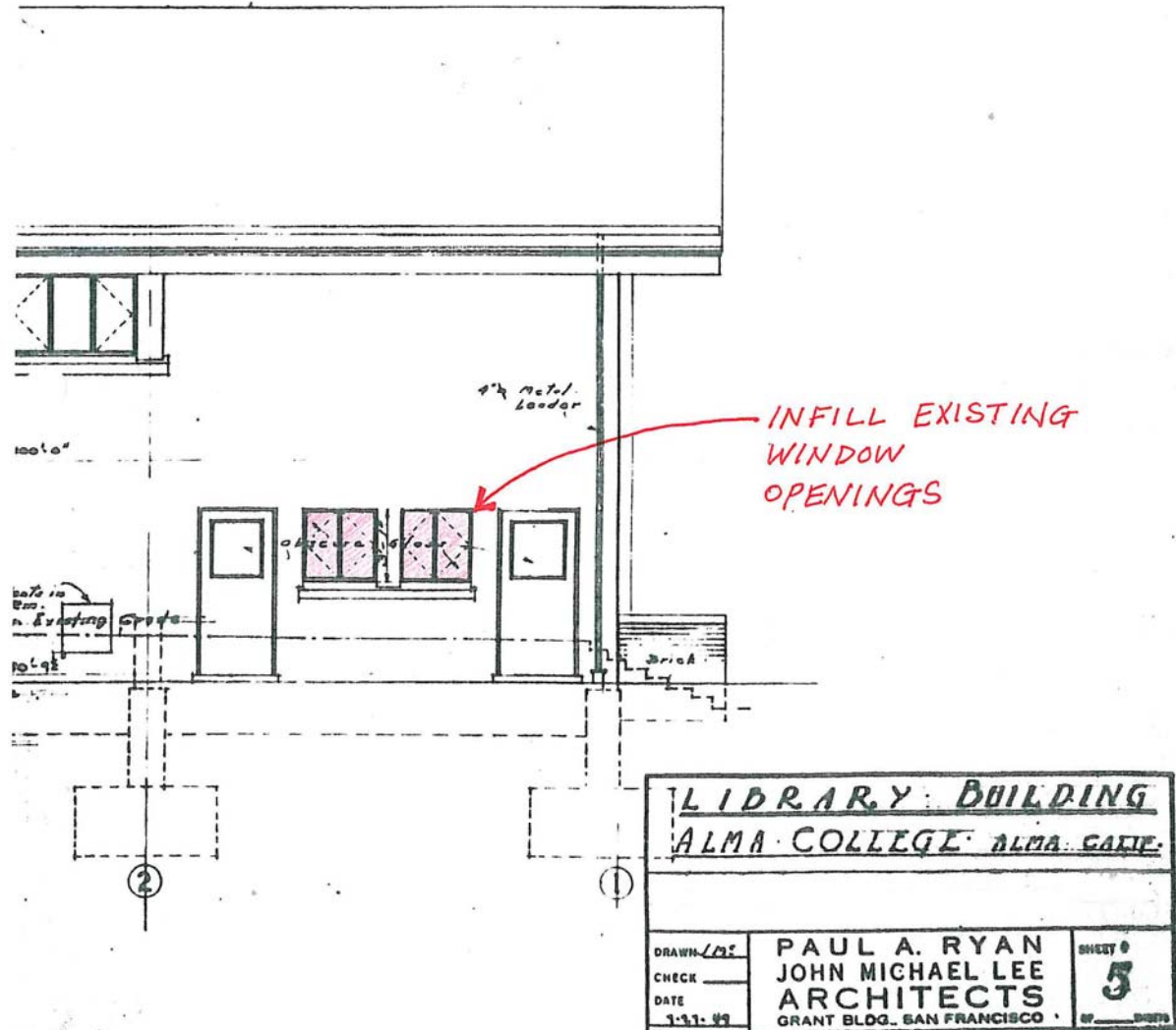

### 1950 Library Structure

Structural Treatment Recommendations:

North wall window infill proposed for shear wall strengthening.



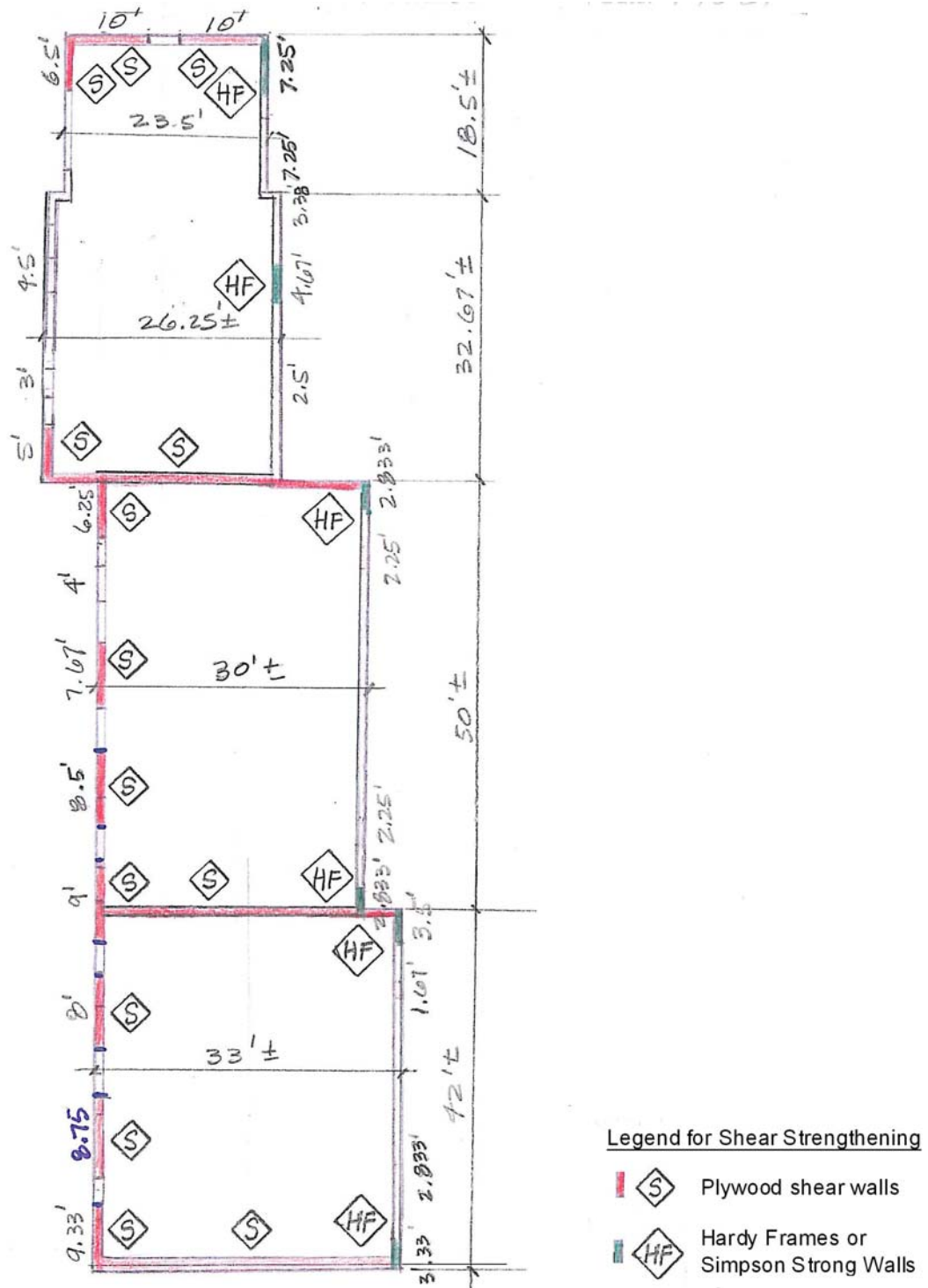

**Classroom**

Structural Treatment Recommendations:

New plywood and frames at existing walls proposed for shear wall strengthening.





**II. ASSESSMENTS & ANALYSES**  
**SECTION D - ARCHITECTURAL ASSESSMENT**

- Exhibit D-1. Architectural Survey & Abbreviations Key
- Exhibit D-2. Historic & Current Photographs of Buildings
- Exhibit D-3. Alma College Site Conditions & Adaptability



---

**II. ASSESSMENTS & ANALYSES**  
**SECTION D - ARCHITECTURAL ASSESSMENT**

---

**Architectural Survey**

The architectural survey focused on the current physical condition and deterioration of existing structures in greater detail than in previous studies considering the findings of the geotechnical and structural engineers. The survey focused on the three main building structures and several ancillary structures remaining on the site.

**Main Structures Survey**

The three main structures include the Chapel, Library (1934 and 1950 structures), and the Classroom building. The Chapel and 1934 Library are in fair condition overall. The 1950 Library is the most intact and structurally stable and well documented of the main structures. Although the Classroom building appears to have stable foundations, its roof is in poor condition with major warping and material deterioration. Its proximity to the subsidiary seismic fault also makes the Classroom building the least stable of the structures, requiring the most work to retrofit for a non-habitable use.

For a better understanding of building conditions, the exhibits for this section should be actively referenced, see Exhibit D-1: Architectural Survey, Exhibit D-2: Historic and Current Photographs of Buildings, and Exhibit D-3: Alma College Conditions & Adaptability. The following summarizes several major existing conditions that affect the main structures and their proposed treatment:

1. Roof Deterioration – Water damage at eaves and at interior ceilings imply roofing system failure. At the Chapel, 1934 Library and Classroom buildings, exterior visual survey indicated asphalt shingle deterioration, sheathing and flashing damage. The interiors did not show major signs of leakage. The south side of the 1950 Library clay tile roof has minimal damage as viewed from below; the north side is less visible. The interior of the 1950 Library shows signs of water damage at the peak and in limited ceiling locations. Re-roofing and installation of gutter and downspout systems would need to occur at each building both for condition and for installation of new seismic diaphragms.
2. Wood Deterioration – At the Chapel, 1934 Library and Classroom buildings, eaves and roof elements are the most exposed and deteriorated – dry rot, splitting, misaligned members. Rehabilitation would involve consolidating deteriorated existing wood where possible, dutchmen where appropriate, and replacement in-kind where severely deteriorated. Rakes had minor deterioration and some loose members. These could be treated and re-attached. Siding is fairly intact but may be brittle and dry. Installation of new shear wall material would require complete replacement of shingles in-kind at the Chapel and Classroom buildings.
3. Vegetation – Overgrown vegetation brings moisture close to the building and wall surfaces. Vegetation should be cut back and maintained at each main structure.
4. Drainage – The existing conditions at each of the main structures do not promote proper drainage of water due to vegetation overgrowth and grading. Vegetation

should be cut back and drainage to promote flow away from buildings should be considered as part of overall site drainage. Gutter and downspout systems at buildings should be integrated with site drainage.

5. Foundations – At the Chapel and Classroom buildings, cracks and mortar deterioration were noted in locations at the brick foundation. Brick is fairly intact but repointing of mortar joints would be necessary. The brick facing at the 1934 Library would need to be repaired where missing and mortar joints repointed. The concrete foundations at the 1950 Library may require minor architectural repair of spalls and cracks. Waterproofing at the foundations may be considered along with site drainage.
6. Removal of Vermin – The Chapel building appears to have the highest population of visible vermin. Bats have congregated at limited locations at the Chapel trusses and within the walls and ceiling of one side chapel. Guano has collected but the carpeting has protected most of the wood floor surfaces. The District has mentioned that a specialized team would clean out the buildings to be reused once bats have been relocated. For any future use, mitigation would need to be considered when dealing with the bat population.
7. Paint – At each main structure, paint finishes are deteriorated, faded and flaking. New paint where it existed is recommended to protect surfaces. Paint vandalism exists at various locations on wood and brick surfaces. Vandalism could be removed with treatment or replaced with new in-kind materials where possible. Use of the site may discourage vandalism but appropriate lighting and security measures may be necessary.
8. Windows and Doors – At each main structure, broken glazing was observed at windows and doors. Door leafs and frames were misaligned, warped or damaged. Repair of these elements requires special care and detailed work that may need to be done in a workshop rather than in-place depending on their condition and the new use of a structure.

The conditions described are common to historic buildings but because the site was neglected for many years, the extent of repair is not comparable to and surpasses that of buildings in continuous use. A new proposed project would involve additional work to renovate interiors of buildings and improve mechanical, electrical and plumbing systems as required by the new use and code.

### **Ancillary Structures Survey**

The North Walkway includes a clay tile veranda at the north side of the Chapel and wood floor extending from the west end of the Chapel to the west end of the 1950 Library. Vegetation has grown over the clay tile and the wood walkway has partially collapsed and is severely damaged. The covered portion of the walkway consists of wood beams that rest on the building roofs and project out to meet wood posts that are attached to the north retaining wall. The roof is composed of wood planking, corrugated plastic roof at the east and corrugated metal roofing at the north. The condition of the wood members is poor with water damage and deterioration at the roof and bowing of the beams. The metal roof is rusted. The covered portion of the walkway should either be removed or rebuilt. The walking surfaces would require repointing and reglazing of

the clay tile paving at the Chapel and rebuilding of the wooden plank walkway adjacent to the Library.

The East Walkway is wood-framed with large beams and posts, glazed openings and wood panels at the base. The East Walkway used to extend from the east side of the Chapel to the Tevis House / Faculty Residence. The walkway was mostly destroyed in 1970 by the fire that destroyed the Faculty Residence. The two bays that remain adjacent to the Chapel still stand but have fire damage, missing glazing, and deteriorated wood members and paneling, and a collapsed wood floor. At the remaining bays, damaged material could be replaced in-kind or, by using the remaining bays and historic documentation as a reference, reconstruct the walkway.

The Garage/Residence is in poor condition. Similar to the Classroom, it is adjacent to a subsidiary earthquake fault. The building is engaged with the retaining wall and stands against a steep slope that poses a fall hazard. Visual survey was performed from outside the chain link fence which did not provide access to the building. The roofing material and sheathing are deteriorated. The brick and concrete wall materials appear intact but portions of wood-framed infill walls, windows and a door are missing. The exterior stairway to the lower level is mostly missing and the remaining portions are severely damaged. Even though the Garage / Residence is mostly intact, its close proximity to a subsidiary trace fault means it cannot be made habitable. As a secondary structure, it could be demolished or retained but made inaccessible to the public depending on the level of hazard management required.

Ancillary structures in ruin include the Tevis House / Faculty Residence and Dormitory buildings. The remaining material is in fair condition and would require stabilization to be reused as an interpretive site. Debris and vegetation should be removed from these ruins and minimal repair performed to protect the remains from further deterioration. The ruins should be assessed for hazards and remediation applied.

The Tevis House / Faculty Residence Carports A & B are the only remaining portion of the Faculty Residence destroyed by fire in 1970. Visual survey was performed from outside the chain link fence which did not provide access to the carports. At Carport A, the brick and concrete appear intact but wood beam panels are fire damaged. Vegetation has grown over the rear arches and lower terrace on the east side of the carport and the materials are less visible. Carport B roof beams are deflected and the corrugated roof is damaged and displaced.

The Dormitories were demolished in 1969 and only the foundations remain. The ruins are obscured by vegetation growth, contain debris and may pose a fall hazard because of their depth below grade.

The Wood Shed southwest of the Classroom is in poor condition. The finish material appears intact but the wall assembly is partially collapsed. The shed walls could be set right and new foundations provided to stabilize it for future use. It is a minor feature and its date is unknown, so, it could be demolished but because it retains some characteristics of the early Alma College period buildings, it could also be retained as contributor to the site.

The non-historic concrete masonry unit (CMU) Shed, north of the Dormitories, is intact but was not surveyed. It could be demolished or used for a secondary function.



### Architectural Survey & Analysis - Abbreviations Key

The Alma College property has been vacant for many years. The key ratings assume a base level of substantial deterioration due to neglect that are not comparable to ratings for buildings in active use.

#### Conditions Key

Key Symbol	Meaning	Description
E	Excellent	Feature is intact and retains character
G	Good	Minor limited deterioration, but feature is intact, repairable, and retains character
F	Fair	Deteriorated portions of feature require replacement, portions that remain retain character
P	Poor	Severe deterioration, none or remnants of feature remain, and do not retain character of original intact feature
O	Obscured	Feature obscured by subsequent additions or other
M	Missing	Feature removed
NE	Not evaluated	The feature was not evaluated for this study but could require future study for conditions.
N/A	Not applicable	The survey did not address items that were not applicable to the discipline.

#### Adaptability Key

Key Symbol	Meaning
1	Highly adaptable requiring reasonable work and expense
2	Moderately adaptable requiring increased work and expense
3	Low adaptability requiring substantial cost
4	Adaptable for interpretive value requiring stabilization of ruin

#### Significance Key

Key Symbol	Meaning
S	Significant contribution to cultural landscape as primary defining element
C	Contributes to cultural landscape as a secondary element

**Architectural Survey**

**CHAPEL  
(1909/1934)**

<i>Feature</i>	<i>Condition Description</i>	<i>Rating</i>
Main (original) Gable Roof & Eaves	Asphalt shingles intact at south, some detachment, north not visible. Eave features obscured by north walkway and side chapels.	G
Main Roof gable rake with vertical boards, stick work, brackets & fascia boards	East - deterioration from exposure, paint peeling, separations at vertical boards, horizontal fascia board detached. West - only lower portion & brackets visible	F
West addition gable rake, vertical boards, brackets & fascia boards	Upper gable flush with wall, smaller gable on addition overhangs.	E
Wood wall shingles	South side chapel shingles most exposed & deteriorated. Other areas intact, paint vandalism.	F
Clinker brick foundation	Brick in good condition, grout poor at corners & some open joints	G
Tall multi-pane French doors	(3) of (6) - broken glazing. Splintered wood.	F
East Walkway (once connected by covered walkway to Tevis Mansion)	(2) bays remain. Wood floor-portion intact near clay-tile veranda, exposed subfloor at remainder to Tevis mansion, hazard. Roof sheathing rotted as seen from interior. Beam ends-poor attachment, vegetation growth. Glazing at windows broken, warped wood frame. Wood members-general dry rot, fire/heat damage at east.	P
North Entry Porch (west addition) with wood stair, railing, shed roof & brackets	Door covered at exterior. Gable roof lapped by loggia roof, condition not visible.	G
North Covered Loggia with wood posts & roof	Water damage at beams under covered portion. Wood water stained, may be rotted, some paint vandalism. Partially visible corrugated plastic and metal roof - partially missing, rusted edge.	F
Clay-tile veranda paving & grout, wood railing	North & East - Cracks, vegetation growth, wear. South - Veranda removed during Alma College period. Wood railing - misaligned, missing pickets, original cap replaced, existing cap deteriorated	F M P
Vaulted, open-beamed ceiling	Intact, some detached beam cover boards, possible damage where bats congregate.	G
Chimney & Fireplace	Removed during Alma College period.	M
Wood floors	Covered with carpet except about 3' at edges of room, floor covered in guano especially at (2) locations	G
Paneled walls	Wood paneling intact	G
Side chapels ( two added on Chapel north & south elevs)	Intact. Northeast chapel - bats within walls, liquid stains at ceiling.	G - (3) F - (1)
Side chapel gables	South - good condition, North - obscured by loggia roof	G - (2) O - (2)
Side chapel windows	Approx. size: 2' x 3' high, fixed, trim intact, windows intact at southwest chapel only, other chapel - damaged or missing glazing	P
Altar platform in main chapel	Intact, partially covered with carpet, guano	G
West addition room	Infill cabinetry, furniture, debris, minor wood wall damage	F
West addition windows	Approx. size: 2' x 4'high, double hung.	G
Basement level	Interior finishes in disrepair, guano at floor	F



**Architectural Survey**

	<i>Feature</i>	<i>Condition Description</i>	<i>Rating</i>
<b>LIBRARY (1934)</b>	Gable Roof	Asphalt shingles & sheathing edge deterioration. Original gutters - some detached/missing	P
	Wood Dormers at roof with louver vents	South - water damage, wood deterioration, North - less wood deterioration, (1) louver missing	P
	Eaves with exposed rafters	Water damage, wood deterioration	F
	Gable decorated with stick work, brackets & beams	East - dutchmen at part of upper gable rake board, lower gable, minor board detachment, beam detached from rake board. West - truncated by New Library addition	G
	Wood shingles	South upper wall - some dry rot, paint flaking at lower shingles, bee hive at west side window opening. East lower wing - south, east, north elevations - intact, some loose shingles, water stains especially at joint with brick building	F
	Clinker Brick wall & foundation	South - loose brick/removal, paint vandalism, opening at base of wall at new library. East - grout deterioration. North - grout intact.	G
	West section of building	Removed for construction of 1949 Library addition.	M
	South Entry Porch with gable roof, fascia, brackets, stick work over vertical boards, and spindle screen	Porch substantially intact. Brackets ends and fascia notches deteriorated. Roof valley and edges deteriorated and separated.	G
	Clay-tile paving at porch	Eroded at step, grout deterioration	F
	Multi-pane metal casement windows	Substantially intact, few broken features	G
	Wood Doors	Intact	G
	North Covered Loggia with wood posts & roof	Dry rot, vegetation growth. Roof sheathing - water damage, bowed. Floor boards uneven, bowed. Partially visible corrugated metal roof - rusted at edge	P
	Wood water table trim	Intact, displaced at corners, nosing damage at east	G
Interior space	Infill wood-framed loft within main double-height space with lower kitchen area. Interior concrete surfaces intact with stains and peeling paint. Vestibule / front offices with wood paneling intact, acoustical tile in disrepair.	F	

**Architectural Survey**

	<i>Feature</i>	<i>Condition Description</i>	<i>Rating</i>
<b>LIBRARY (1950)</b>	Low pitched gable roof with clay tile	South - minor tile displacement at south side. North - not easily visible above loggia roof, covered with tree needles & leaves	F
	Deep overhanging eaves	Minor wood fascia detachment. Water damage at south soffit. North eave less visible above loggia roof.	F
	North concrete chimney	Concrete above roof - spalls, damage at roof penetration, missing stucco at walkway under loggia roof.	P
	Stucco finish at concrete walls	Cracks, spalls, water damage, flaking paint	F
	South façade: low colonnade at first story, flat walkway at second, Concrete Jesuit seal at West end	Concrete base - minor cracks. Colonnade - large crack at end (center of building).	G
	North Covered Loggia with wood posts & roof	Spaces between roof sheathing, severe cant at wood board floor & stair, water damage	P
	West full-height, multi-pane fixed window	Glazing broken, wood frame substantially intact, overall shape & divisions remain	F
	Metal casement windows under eaves	Exterior - not visible. Interior - sash intact, screen panel damage, glazing broken at some north windows	F
	North metal door	Metal frame intact, glazing broken, difficult to open	F
	Large vaulted interior space	Murals intact but faded. Ceiling peak appears to have water damage, possible rust stain. Northwest corner ceiling - water damage.	F
	Stairs to Basement	Southwest stair closed off. Northeast stair and basement not investigated.	NE
	Basement	NE	NE

**Architectural Survey**

	<i>Feature</i>	<i>Condition Description</i>	<i>Rating</i>
<b>CLASSROOM BUILDING (1934)</b>	Gabled Roof	Roof shape warped. Severe shingle deterioration, missing flashing at locations, water damage at roofing, sheathing edge, eave soffit	P
	Eave & rafter tails	Water damage, deterioration	F
	East Gable End Decorated with Stick work and Bracing	Upper gable - stick work detachment, bracket ends deteriorated	F
	West Gable	Finish material (assumed to be board & batten) missing, gable aligned with wall, no roof overhang	M
	Wood wall shingles	North & south elevations at east section of building - ivy growth at north, south intact	F
	Board & batten wall finish	North elevation at clerestory windows above arcade - intact with water damage	F
	East section of building	No access.	
	Double-hung windows	Interior section of building - intact at classroom.	F
	Clerestory windows above north arcade	Substantially intact, paint flaking. (1) wood screen broken, (1) window with broken glazing	F
	Multi-pane glazed doors at classroom entrances	Splintered wood, missing panel at mid-section of building	F
	North Porch Entry with gable roof, brackets & fascia boards	Biological growth/ivy, roof & bracket end deterioration, water damage at wall	P
	South Porch Entry with gable roof, brackets, fascia boards, brick paving & steps to concrete steps	Roof eave deterioration, water damage. Wood substantially intact, stair rail newel post top deteriorated	F
	Classrooms finishes	West section of building - Wood ceiling obscured by acoustical tile ceiling Wood wall paneling & trim work intact. East section - no access.	O G NE
	Brick foundation	Not easily visible with vegetation. North - grout missing especially at arcade. South - large hole under window	F
	East concrete retaining wall	Creates moat, debris and vegetation	F
	Wood grilles at brick openings & wood water table trim above brick foundation	Holes in grilles. Water table corners damaged, detached.	P
	Brick vestibule with spindle screen openings, brick stair to entry	Wood substantially intact, Roof, wood eaves & rake - wood deterioration. Biological growth/ivy.	G
	Arcade vertical wood siding	Intact, paint vandalism	G
Arcade posts & lintels, railing	Retrofit metal straps, missing rail pickets, loose rail	F	
Clay tile paving at porch	Biological growth/ivy, wear	F	

**Architectural Survey**

<i>Feature</i>	<i>Condition Description</i>	<i>Rating</i>
----------------	------------------------------	---------------

**Miscellaneous Features - Demolished, Collapsing, in Ruins or Hazardous**

**GARAGE /  
RESIDENCE  
(1940s)**

Building	Multi-story building at steep grade change, hazard. No Access. Visual observation from outside fence.	P NE
Roof	Roof, flashing, sheathing deteriorated.	
Brick piers at west	Intact.	
Concrete walls	Intact.	
Infill wood-framed walls	Partially intact.	
Windows	Missing at uppermost level.	
Door	Missing at lower level.	
Exterior Stair	Damaged and partially removed	

**WOOD SHED**

Gable roof	Asphalt shingle roof & eave deteriorated, thick layer of leaves & needles on roof	P
Eave & rafter tails	End deterioration, water damage	F
Gable rake with center bracket & rake board	West - Bracket intact, rake board severe deterioration, board & batten at gable intact, East - bracket intact, decorative	F
Board & batten siding at walls	Walls warped, collapsing. Siding intact with some deterioration.	P
West double shed doors - full width of east wall	Upper panel vertical boards, lower panel slanted boards. Doors intact but warped, deteriorated at bottom.	P
Six-pane window	North - sash exists, glazing broken, South & East - no sash	P

**TEVIS HOUSE /  
FACULTY  
RESIDENCE  
(1909-1969)**

Building	Substantially missing. No Access. Remaining portions as listed were visually observed from outside fence.	R NE
Concrete retaining wall West side of building	Standing but large crack near southeast corner.	
Carport A Northeast side of building	Brick & concrete structure, interior space, east arched opening & lower terrace. Brick & concrete appear intact, wood roof missing & deteriorated, wood ceiling beams and rafters deflected, fire damaged & deteriorated.	
Carport B Southeast side of building & north of Garage	Intact brick piers with poor grouting detail, deflected wood beams, displaced/damaged corrugated metal roof.	

**DORMITORIES  
(1934-1937)**

Building Limited access.	Limited access. Substantially demolished after Alma College period.	R NE
Foundations	Joist pockets, foundation vents below existing grade, unexcavated crawl space	
Wood Framing	Lightweight wood construction at center.	
Steel windows at north.	NE	
Brick terrace	Between dormitory and classroom building Partially intact, brick paving & piers are damaged.	



Image 1. Tevis Library, historic exterior view of south and east façades with a wrapping veranda with railing and the original walkway to the Tevis House to the east (not shown). (California Jesuit Archives, Santa Clara. Alma College File.)



Image 2. Tevis Library, historic interior view showing the original fireplace. (California Jesuit Archives, Santa Clara. Alma College File.)



Image 3. Alma College Chapel, historic exterior view of south facade. The Jesuits converted the Tevis Library to a chapel. The Tevis period veranda was removed and side chapels were added during the Alma College period. The East Walkway to the Faculty Residence is shown at the right. (California Jesuit Archives, Santa Clara. Alma College File.)



Image 4. Alma College Chapel, historic interior view at the northeast corner. The side chapels and altar steps at the left were added during the Alma College period. The Tevis library fireplace on another wall was removed. (California Jesuit Archives, Santa Clara. Alma College File. Photograph by Gabriel Moulin Studio, San Francisco, May 1950.)





Image 5. Alma College Chapel, existing exterior view of the south facade. As the most exposed side of the building, the wood deterioration is more severe than other sides. (Knapp Architects, digital photograph, 2009)



Image 6 & 7. Alma College Chapel, existing exterior view of the north façade (left) and west façade (right). The building has sustained paint vandalism at various locations. The clay tile at the north veranda is worn and has some vegetation growth. The north covered walkway obscures the upper façade and roofline. (Knapp Architects, digital photograph, 2009)



Image 8 & 9. Alma College Chapel, existing interior view to the west (left) and detail of corner with wood paneling (right). An indigenous bat population lives within the building. Carpeting has protected the floor from bat guano collection. The wood wall paneling is intact and appears to be in good condition. (Knapp Architects, digital photograph, 2009)



Image 10. Alma College Chapel, existing interior view of a basement space. The basement has limited wood paneling but does not appear to be historically significant. (Knapp Architects, digital photograph, 2009)



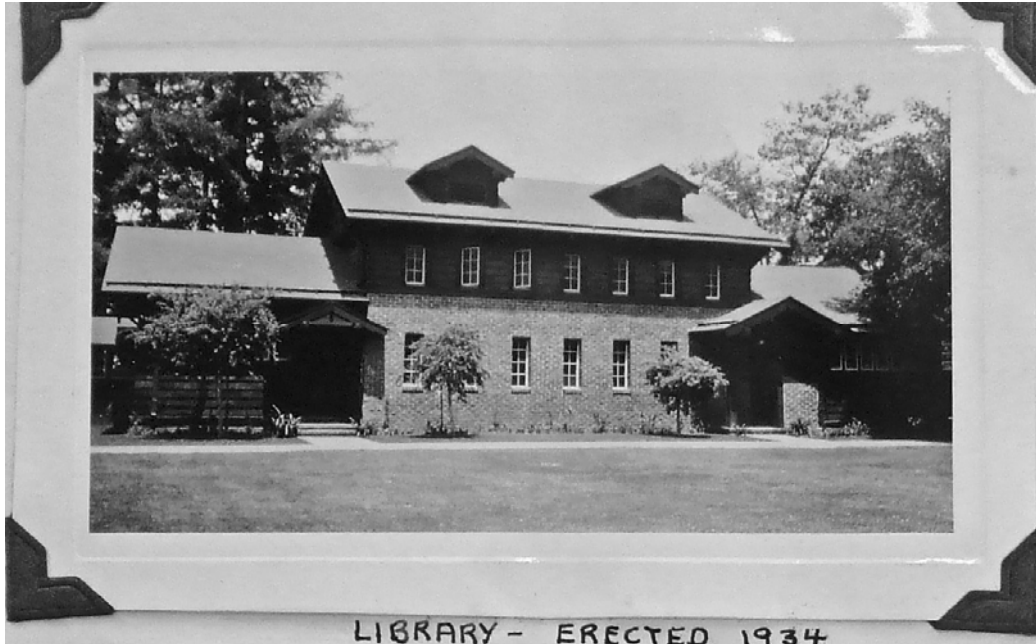

Image 11. Alma College 1934 Library, historic view of south façade. (California Jesuit Archives, Santa Clara. Alma College File.)



Image 12. Alma College 1934 Library, historic view of from the southwest. (California Jesuit Archives, Santa Clara. Alma College File.)



Image 13. Alma College 1934 Library, existing view of south façade. The lower building projection at the west side of the building was removed when the new library addition was built in 1949. (Knapp Architects, digital photograph, 2009)

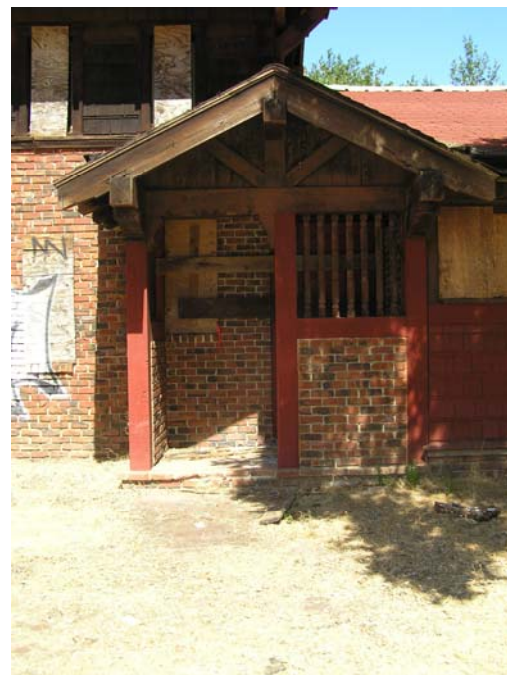

Image 14 & 15. Alma College 1934 Library, existing view of the north façade (left) and south porch (right). The wood floor at north walkway is uneven and damaged and the walkway roof obscures part the lower façade. The entry porch is intact with minor damage at the brick step. (Knapp Architects, digital photograph, 2009)





Image 16. Alma College 1934 Library, existing view of south-facing roof dormer. (Knapp Architects, digital photograph, 2009)



Image 17. Alma College 1934 Library, existing lower east roof, upper roof and roof dormer viewed from the southeast. The woodwork, roof material and sheathing are deteriorated. (Knapp Architects, digital photograph, 2009)



Image 18 & 19. Alma College 1934 Library, existing interior view of north wall (left) and detail of window (right). The character of the space and its industrial steel sash windows is intact. (Knapp Architects, digital photograph, 2009)



Image 20 & 21. Alma College 1934 Library, existing interior view of vestibule (left) looking north and library space with non-historic stair and loft looking southeast. (Knapp Architects, digital photograph, 2009)



Image 22. Alma College 1949 Library addition, historic view from the southwest. (California Jesuit Archives, Santa Clara. Alma College File.)



Image 23. Alma College 1949 Library addition, historic view from the southeast. An entryway is shown at the corner where the new library meets the old library. (California Jesuit Archives, Santa Clara. Alma College File.)





Image 24. Alma College 1949 Library addition, existing interior view looking west. The large interior vaulted space is shown with the full-height west window. (Knapp Architects, digital photograph, 2009)



Image 25. Alma College 1949 Library addition, existing interior view looking east. Murals at the ceiling and walls are visible. A band of windows is seen at the right. Brown staining at the peak of the vault implies water infiltration. (Knapp Architects, digital photograph, 2009)



Image 26 & 27. Alma College 1949 Library, existing north windows (left) and doorway (right). Window screens and glazing are damaged. The glazed door operability requires repair. (Knapp Architects, digital photograph, 2009)



Image 28. Alma College 1949 Library, existing interior view of full-height west window and mural at north wall. The west window framing is substantially intact but the glazing is broken. (Knapp Architects, digital photograph, 2009)



Image 29. Alma College Classroom Building, historic view of north façade from the northeast. (California Jesuit Archives, Santa Clara. Alma College File.)



Image 30. Alma College Classroom Building, historic interior view of a classroom. (California Jesuit Archives, Santa Clara. Alma College File.)





Image 31. Alma College Classroom Building, existing exterior view of north façade. The dark lines at the roof are displacement cracks where the roof form is warped ((Knapp Architects, digital photograph, 2009)



Image 32 & 33. Alma College Classroom Building, existing exterior view of the southwest corner (left) and east façade (right). The west façade finish material is missing. The east façade has incurred some paint vandalism at the shingles. (Knapp Architects, digital photograph, 2009)





Image 34 & 35. Alma College Classroom Building, existing exterior view of typical bay at the arcade (left) and interior view along the arcade (right). Vegetation has invaded the perimeter of the building, grown onto the building and at the floor of the arcade. (Knapp Architects, digital photograph, 2009)



Image 36 & 37. Alma College Classroom Building, existing exterior view of secondary north entryway and south entry porch with stair. Lack of gutters has allowed water to flow from the roof down onto the walls which are water-stained. (Knapp Architects, digital photograph, 2009)



Image 38. Alma College Classroom Building, existing exterior view of roofline at main south entry porch at left. The roofing and wood sheathing are deteriorated. Vegetation growth on the building brings moisture that increases wood deterioration. (Knapp Architects, digital photograph, 2009)



Image 39. Alma College Classroom Building, existing exterior view of retaining wall at east façade which creates a partial moat where vegetation and debris have collected. (Knapp Architects, digital photograph, 2009)





Image 40. Alma College Classroom Building, existing interior view looking north at a classroom entry to the exterior arcade and upper clerestory windows. Historic wood paneling and trimwork is intact. The finish at the partition wall at the right is partially removed. (Knapp Architects, digital photograph, 2009)



Image 41. Alma College Classroom Building, existing interior classroom view looking south to the large double-hung windows and chalkboard at the right. The non-historic acoustical tile ceiling obscures the view of the original ceiling above. (Knapp Architects, digital photograph, 2009)



Image 42. Alma College Classroom Building, existing interior view of original intact glazed doors. (Knapp Architects, digital photograph, 2009)



Image 43. Alma College East Walkway, historic exterior view from the southwest. The walkway connected the Chapel (left) to the Faculty Residence (right) but was damaged in the fire that destroyed the Faculty Residence in 1970. (California Jesuit Archives, Santa Clara. Alma College File.)



Image 44. Alma College North Walkway, historic exterior view of walkway between the Dormitories (left) and the 1934 Library (not shown to the right). (California Jesuit Archives, Santa Clara. Alma College File.)



Image 45. Alma College East Walkway, existing exterior view from the southeast attached to the Chapel east façade. The wood floor is damaged and open to subflooring. (Knapp Architects, digital photograph, 2009).



Image 46 & 47. Alma College East Walkway, existing exterior view of lower wood panels and windows (left) and upper wood beam framing. The glazing at windows is missing or broken. The wood at the east end of the remaining portion of the walkway shows evidence of fire damage. (Knapp Architects, digital photograph, 2009)





Image 48. Alma College East Walkway beyond, existing view inside the North Walkway from the northeast corner of the Chapel. At the left, a brick stair, covered by a shed roof with corrugated plastic, leads to the Chapel basement entry . Vegetation growth is seen at the veranda clay tile. (Knapp Architects, digital



Image 49. Alma College North Walkway, existing view from the northwest corner of the Chapel. The veranda railing appears similar to the original seen in a historic photograph of the south and west sides of the Chapel, see Image 1. The covered walkway roof, beams and posts are also shown. (Knapp Architects, digital photograph, 2009)





Image 50 & 51. Alma College North Walkway, existing interior view looking east (left) and exterior view from the south (right). The stair transition is shown from the brick veranda at the Chapel down to the wood flooring at the 1934 Library. The exterior view shows the cupola atop the pitched walkway roof. (Knapp Architects, digital photograph, 2009)



Image 52 & 53. Alma College North Walkway, existing interior view looking west (left) and exterior view at the 1949 Library addition (right) looking east. The wood walkway and stair are severely canted. (Knapp Architects, digital photograph, 2009)



Image 54-56. Alma College Dormitories, historic exterior views of south facades. (California Jesuit Archives, Santa Clara. Alma College File.)





Image 57. Alma College Dormitory porch ruin, exterior view looking east toward 1949 Library. The brick porch ruin connected the dormitory (left) and classroom (right). The brick paving, stairs and a few piers remain. (Knapp Architects, digital photograph, 2009)



Image 58. Alma College Dormitory ruins, existing exterior view looking north. A portion of the dormitory foundations is visible within which debris has collected. Some metal roofing material covers the ruin. (Knapp Architects, digital photograph, 2009)



Image 59. Alma College Tevis House/Faculty Residence, historic exterior aerial view from the southeast. The Faculty Residence was large, comprised of additions by Tevis and Alma College. The rear façade arches of Carport A are visible to the right of the dark mass of trees at the building. The four bay openings of the Garage/Residence building are shown at the left. Another parking area exists between Carport A and Garage/ Residence. At some point, a covered structure was placed in this area and is referred to as Carport B in this report. (California





Image 60. Alma College Tevis House / Faculty Residence ruin, exterior view looking northwest at the retaining wall that supported a west portion of the house. A large crack in the concrete retaining wall is seen at the left near the wall corner. (Knapp Architects, digital photograph, 2009)



Image 61. Alma College Tevis House / Faculty Residence ruin, Carport A, exterior view looking northeast. A terrace still exists just below and east of the carport. (Knapp Architects, digital photograph, 2009)





Image 62 & 63. Alma College Tevis House / Faculty Residence ruin, Carport A, existing interior view of looking north. The brick facing and concrete structure remain. Wood cover trim has sustained fire damage. The carport has an interior space and rear archways and a lower terrace to the east, not shown. (Knapp Architects, digital photograph, 2009)



Image 64. Alma College Tevis House / Faculty Residence, Carport B (right), existing exterior view looking west. The secondary carport was a parking area adjacent to the Garage/ Residence shown at left. (Knapp Architects, digital photograph, 2009)





Image 65. Alma College Garage/Residence, existing exterior view from the northeast. The brick piers at the four carport openings are shown with wood infill. (Knapp Architects, digital photograph, 2009)



Image 66. Alma College Garage/Residence, existing exterior view from the northwest (left). The multi-story building is composed of concrete and brick. The wood stair to the lower level entry is severely damaged and unusable (right). (Knapp Architects, digital photograph, 2009)





Image 67. Alma College Wood Shed, existing exterior view of west façade with decorative wood shingles and framed barn-like doors. (Knapp Architects, digital photograph, 2009)



Image 68. Alma College Wood Shed, existing exterior view of south façade (left) east façade (right). The roof and walls are partially collapsed. Vegetation debris has collected on the roof. (Knapp Architects, digital photograph, 2009)



Image 69. Alma College shed, historic aerial view from the southeast. A small shed is shown west of the Dormitories. This shed appears similar to the Wood Shed and may be the same, relocated, at some point, southwest of the Classroom during the Alma College period. (California Jesuit Archives, Santa Clara. Alma College File.)



Image 70. Alma College CMU Shed, existing exterior view from the south. The shed is constructed of concrete masonry units and did not appear historic. (Knapp Architects, digital photograph, 2009)





# KnappARCHITECTS

March 2010

Alma College Conditions Assessment  
Phase I - Assessment of Existing Conditions  
Section D - Architectural Assessment

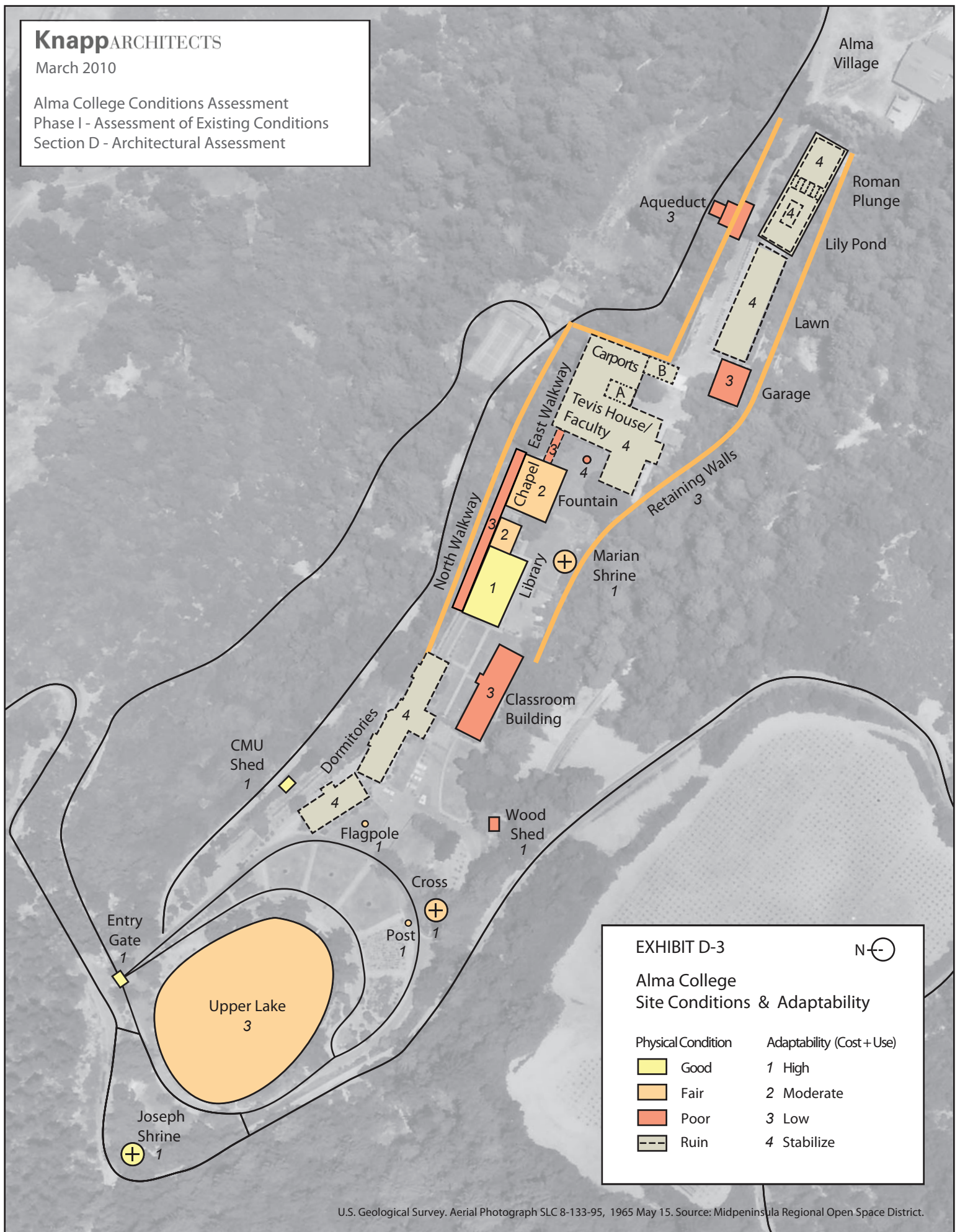





## **II. ASSESSMENTS & ANALYSES**

### **SECTION E - LANDSCAPE ASSESSMENT**

Exhibit E-1.1 - Walls Establishing Level Area

Exhibit E-1.2 - Level Area of Campus Core

Exhibit E-1.3 - Historic Spatial Enclosure

Exhibit E-1.4 - 2009 Spatial Enclosure

Exhibit E-1.5 - Historic Pedestrian Circulation

Exhibit E-1.6 - 2009 Pedestrian Circulation

Exhibit E-2. Historic Site Photographs of Alma College

Exhibit E-3. Landscape Features Plan

Exhibit E-4. Landscape Features - Survey of Conditions

Exhibit E-5. Landscape Features Field Sketches: L1, L4, L6, L9

Exhibit E-6. Current Photographs of Landscape Features

Exhibit E-7. Alma College Ornamental Plant Resource Inventory

(Park, Keith W. "Alma College Ornamental Plant Resource Inventory," Alma College volunteer horticulturalist, 22 July 2009.)



---

## II. ASSESSMENTS & ANALYSES

### SECTION E - LANDSCAPE ASSESSMENT

---

#### Description of the Landscape

For the purposes of this study, the Alma College site is defined as extending from Bear Creek Road near Upper Lake and including all features contained along the flat-topped ridge line to and including the site of the former Roman Plunge. The sides of the flat-topped ridge are established by retaining walls in the southeast and by the road that encircles Upper Lake in the northwest part of this area. This defines the historic core of the Tevis estate and later Jesuit seminary. Additional landscape features lie beyond this boundary including the site of a former gymnasium, entry court, water system, tennis court and equestrian and hiking trails. Since these are entirely or predominantly outside the physical limits of the flat-topped hill where the site was most intensively developed, they are beyond the currently defined Alma College landscape.

The significance and integrity of the site are discussed in the Cultural Landscape Analysis section of this report but it is important to understand, in this section, what makes the landscape significant in order to understand how it can be rehabilitated. The Alma College site is considered a cultural landscape because, viewed as a whole, it represents significant cultural themes in the development of California, particularly the Jesuit period but also earlier periods that are also layered on the site, from the lumber milling time to the country estate period of Dr. Tevis. Exhibit E-4, the Landscape Features - Survey of Conditions, describes extant landscape features and notes whether they are character-defining. The buildings on the site also contribute to the cultural landscape. The level of integrity of the cultural landscape is fair to good but has been impacted by the removal of the two dormitory buildings and the loss to fire of the Tevis House / Faculty Residence. The buildings and landscape features, including those in ruin, and vegetation affect the spatial arrangement of the site.

#### Landscape Survey

The Historic Site Photographs of Alma College, Landscape Features Plan, Landscape Features - Survey of Conditions, Field Sketches, and Current Photographs, Exhibits, E-2 through E-6, describe the features and characteristics of the landscape including:

- Natural systems and features
- Spatial organization
- Land use
- Circulation
- Topography
- Vegetation
- Buildings and structures
- Views and vistas
- Constructed water features
- Small-scale features

A brief description of the key features and characteristics follows:

## Features

Many landscape features are discrete elements such as the St. Joseph Shrine, the Marian Shrine and the semicircular hedge with cross. Some, such as the low posts with shaped, white tops were devices for orienting pedestrians throughout the site during the Jesuit period. At least one of these remains, while many are apparent in the historic photographs. Some features remain in remnant form and are currently obscured by vegetation such as the three formerly coherent elements of the Lawn, Lily Pond and Plunge.

Pervasive throughout the site and key to its presence and physical form are the walls. For this reason walls are addressed separately, below.

## Walls

The peninsula of land, on which the campus sits, is reinforced on each long side by retaining walls that allow for the creation of a level area that today accommodates buildings and relatively flat open spaces, that is, the Alma College campus. The essential task of these walls is that they physically hold up the ridge-top site; by virtue of this role and their sheer extent they are character-defining features. Landscape Exhibits E-1.1 through E-1.6 illustrate the role of the retaining walls and the historic and current spatial properties and circulation of the site. Most of these retaining walls have reinforced concrete below the upper-level grade and freestanding brick walls, usually 16 to 24 inches thick, above that. Where walls do not retain the edges of the ridgeline, they may also be made of mortared or unmortared rock rubble, or, in the case of the level change between the Chapel and the Tevis House / Faculty Residence, reinforced concrete. On the north side of the Chapel and Library, some retaining walls are integral to the buildings. Brick and stone are character defining materials of the site walls as viewed from the cultural landscape point of view.

This report defers to the sections by the structural and geotechnical engineers regarding stability of the walls. This landscape section addresses the role the walls play in the larger cultural landscape. These walls permit the flat space of the ridge-top; without them the sides would slough away, threatening the future stability of the cultural landscape.

## Vegetation

The Alma College cultural landscape has had a vegetation survey completed by Keith Park (Exhibit E-7). Generally there are two types of vegetation – introduced and native. The introduced vegetation that remains represents the hardiest of those species that were part of the Jesuit campus and possibly earlier periods. Trees that remain are drought tolerant and capable of withstanding neglect. More tender species were soon lost after the site was abandoned by the Jesuits. Conifers are a predominant introduced tree type. They are large trees, many with a blue hue, that commonly mark the presence of features. For instance, the Marian Shrine is flanked by a pair of pencil cypress, the Plunge is terminated by a mass of Blue Atlas Cedars, and the semicircular hedge with cross is backed up by a semicircular hedge of Weeping Blue Cedars. Elsewhere a range of tree species exists, such as the Liquidambar at the St. Joseph Shrine and the eclectic mix of species at the grouping of bedrock mortars.

Native vegetation provides the setting for the campus. It has encroached and become denser over time. This vegetation, coupled with the buildings, is responsible for establishing the spatial enclosure of the flat ridge-top site.

## Circulation

The circulation today is along a fire/service road on the south side of the ridge-top (See Exhibit E1.6, 2009 Pedestrian Circulation). Historically, pedestrian circulation was primary. The main pedestrian “spine” was located through the center of the site and it linked Upper Lake to the Tevis House / Faculty Residence. Historically, many more options were available for circulation than are available today, particularly around Upper Lake where radial paths provided easy access to the shoreline path (See Exhibit E1.5, Historic Pedestrian Circulation). The configuration, and to a lesser extent materials, of the pedestrian circulation is character-defining at the Alma College campus.

## Current Condition of the Landscape

1. In its current state, the site is difficult for the visitor to fully comprehend. There are several reasons for this:
  - Historically the approach to the site presented a clear central pedestrian “spine” emanating from the lake and terminating at the Tevis House / Faculty Residence. This spine is no longer available to pedestrians (See Exhibits E1.5 & E1.6, Landscape Circulation Diagrams).
  - This spine was enclosed on both sides by buildings and/or large banks of vegetation. Today several buildings are missing from this historic pattern including two dormitories and the Tevis House / Faculty Residence that enclosed the view (See Exhibits E1.3 & E1.4, Landscape Spatial Enclosure Diagrams).
  - Encroachment on key spaces by vegetation such as the loss of the spatial volume at the lawn between the Garage and former Lily Pond, as well as the open space at the location of the Lily Pond and the Roman Plunge. This lawn has been colonized by *Baccharis pilularis* (Coyote Brush) and the Lily Pond/Roman Plunge have been densely colonized by larger Coyote Brush and Poison Oak.
2. A considerable number of character-defining features are in poor condition. The nature of the maintenance of the landscape features in the future has the potential to improve the ability to both interpret the site and upgrade the condition of some of these character-defining features.
3. A few features are nearly or completely absent, including the Lily Pond, Roman Plunge and adjacent Lawn.
4. Encroachment of vegetation, like that mentioned above at the Lily Pond/Roman Plunge area, is impacting the site as a whole. St. Joseph Shrine was formerly visually open to Upper Lake, and the density and size of vegetation on the periphery of the built area of the campus has increased over time. Also, weeds and Poison Oak are widespread.



5. At the same time, there has been loss of some of the less hardy and/or drought tolerant introduced species that date to the Tevis or Jesuit periods. These plant losses mean that the introduced plants that remain represent a small selection of the original palette.

### **Considerations for Rehabilitation of the Landscape**

1. Reinstating the primary pedestrian access through the center of the site along the historic pedestrian “spine” would significantly help the visitor comprehend the site.
2. Reinforce the historic spatial arrangement of the site by enclosing the central space by extant buildings and/or large masses of vegetation.
3. Maintain the discrete character-defining features as they appeared in historic photographs to improve the visitor’s understanding of the historic layout and usage of the site, e.g. restore St. Joseph Shrine, Marian Shrine and semicircle with hedge and cross.
4. Management of both introduced species and native species will better support the legibility of the Alma College cultural landscape, such as:
  - There are significant numbers of drought-tolerant plants, primarily, though not exclusively, conifers, that date to the Jesuit period. These trees would benefit from pruning, clearing of suckers (e.g. Liquidambar at St Joseph Shrine), and clearing of encroaching vegetation.
  - As noted above, native vegetation has encroached on both the Lawn / Lily Pond / Roman Plunge area and the main central spine. Where the spatial volumes of the site have been altered by the removal of buildings, large banks of native vegetation present a viable alternative to provide the historically appropriate degree of enclosure. Where the encroachment goes beyond this degree vegetation should be removed, pruned or thinned.
  - Weeds and Poison Oak in the historic campus core should be removed.
5. The site lends itself to interpretation of its interesting history. This may take the form of a brochure visitors pick up and carry with them or non-intrusive site maps that show historic pictures of how the features once appeared.

### **Additional Opportunities/Concerns**

As the Alma College cultural landscape will have a new chapter of life under the Midpeninsula Regional Open Space District, several contemporary factors bear on the treatment and maintenance of the site: site safety, accessibility (Americans with Disabilities Act), degree to which it is open to the public, connections to the broader landscape for hiking and equestrian trails and access to and use of irrigation water.

### **Conclusion**

The Alma College site is a cultural landscape with a sizable number of features intact. As the future use of the site has not been determined, it makes sense to retain flexibility where possible. This may be done, in part, by respecting and retaining the historic fabric where feasible.

March 2010

Alma College Conditions Assessment  
Phase I - Assessment of Existing Conditions  
Section E - Landscape Assessment

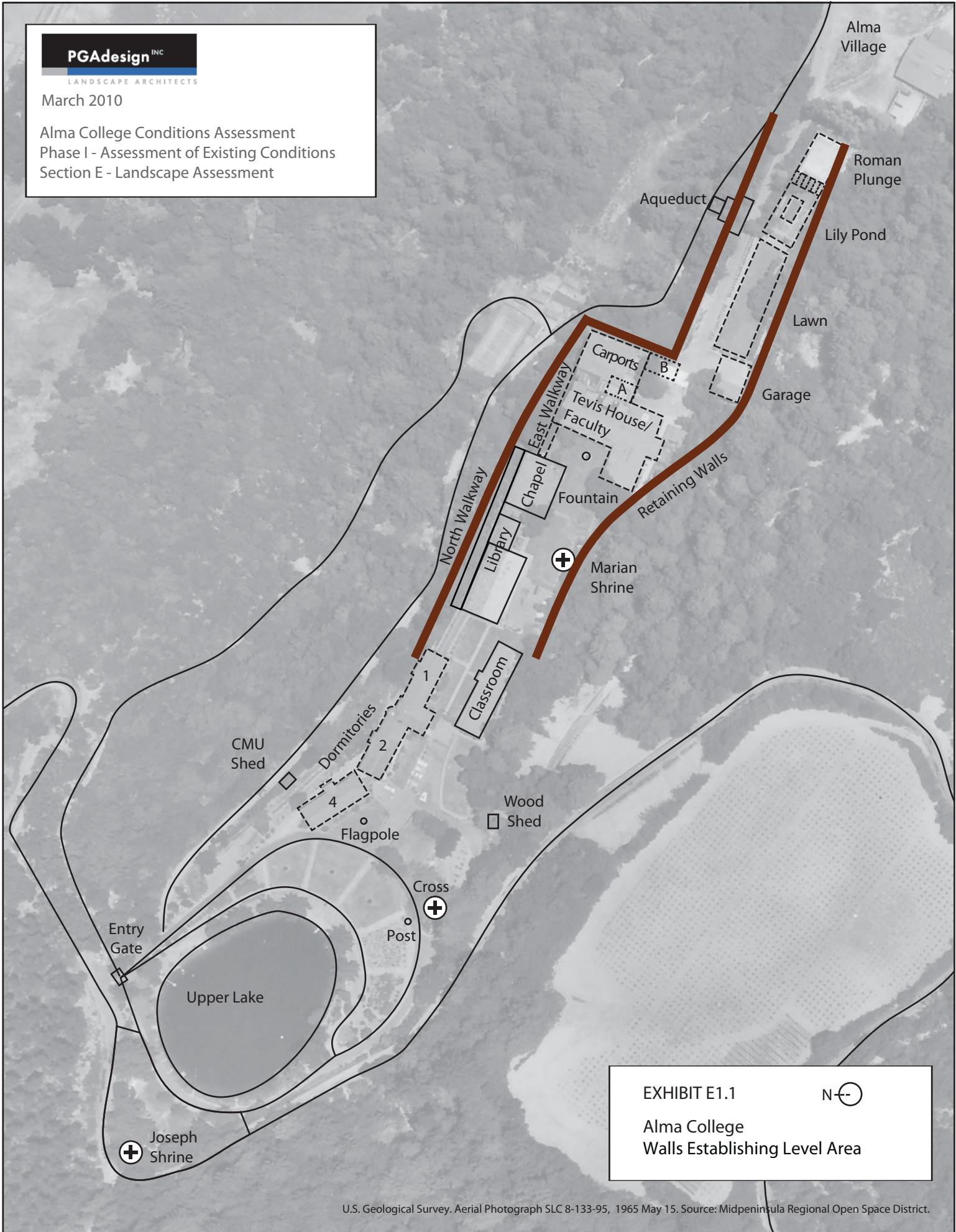

EXHIBIT E1.1      N ↯  
Alma College  
Walls Establishing Level Area

U.S. Geological Survey. Aerial Photograph SLC 8-133-95, 1965 May 15. Source: Midpeninsula Regional Open Space District.



March 2010

Alma College Conditions Assessment  
Phase I - Assessment of Existing Conditions  
Section E - Landscape Assessment

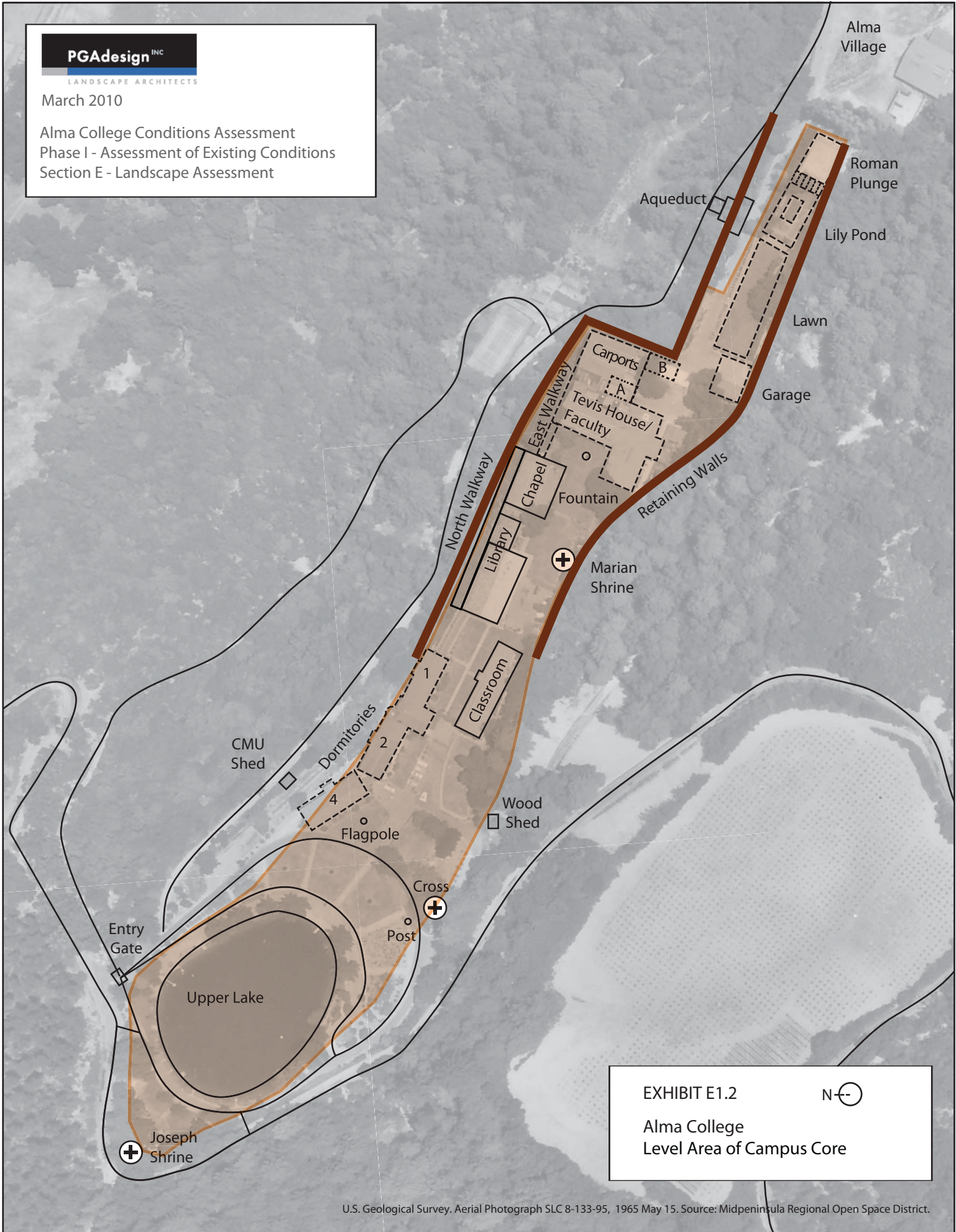

EXHIBIT E1.2      N ⊕  
Alma College  
Level Area of Campus Core

U.S. Geological Survey. Aerial Photograph SLC 8-133-95, 1965 May 15. Source: Midpeninsula Regional Open Space District.



March 2010

Alma College Conditions Assessment  
Phase I - Assessment of Existing Conditions  
Section E - Landscape Assessment

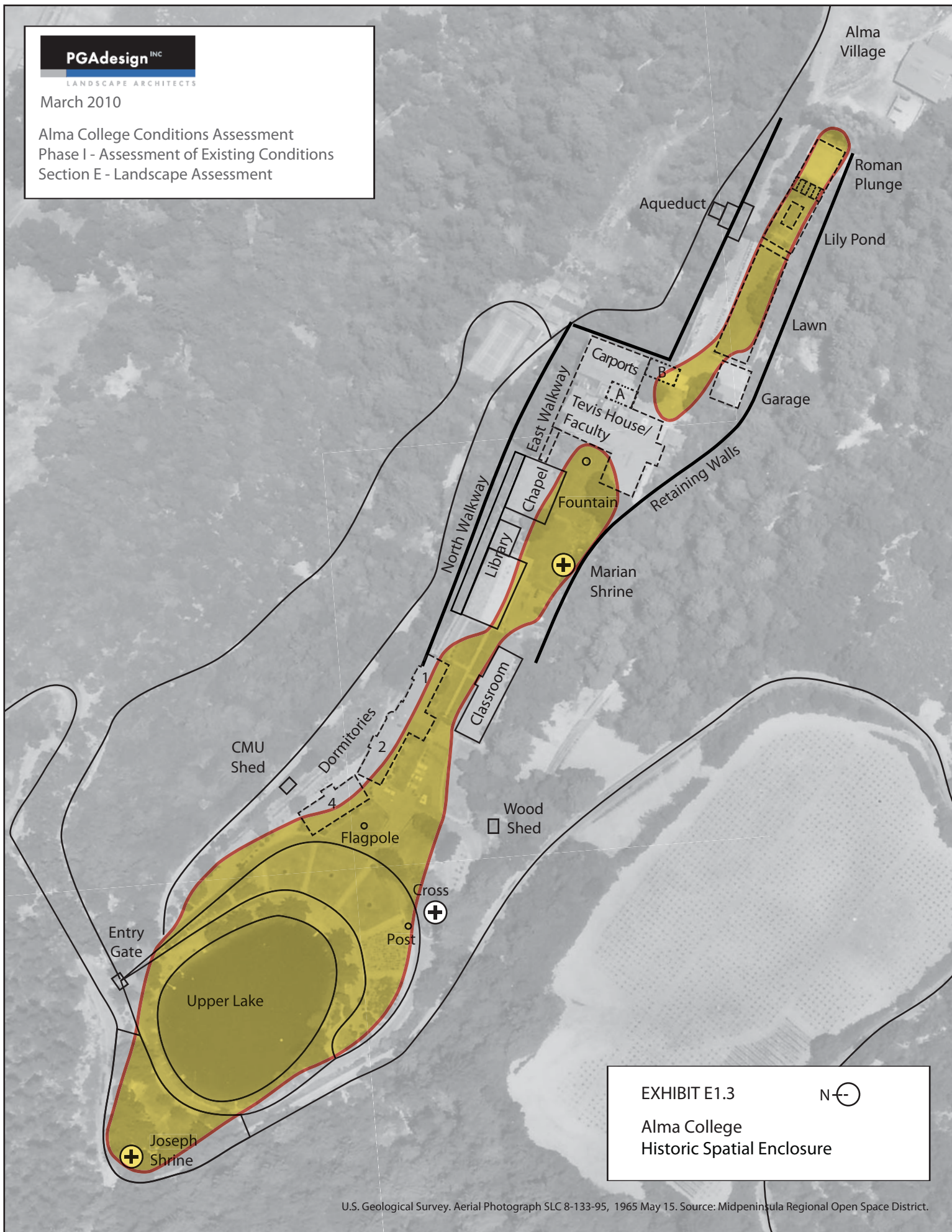



March 2010

Alma College Conditions Assessment  
Phase I - Assessment of Existing Conditions  
Section E - Landscape Assessment

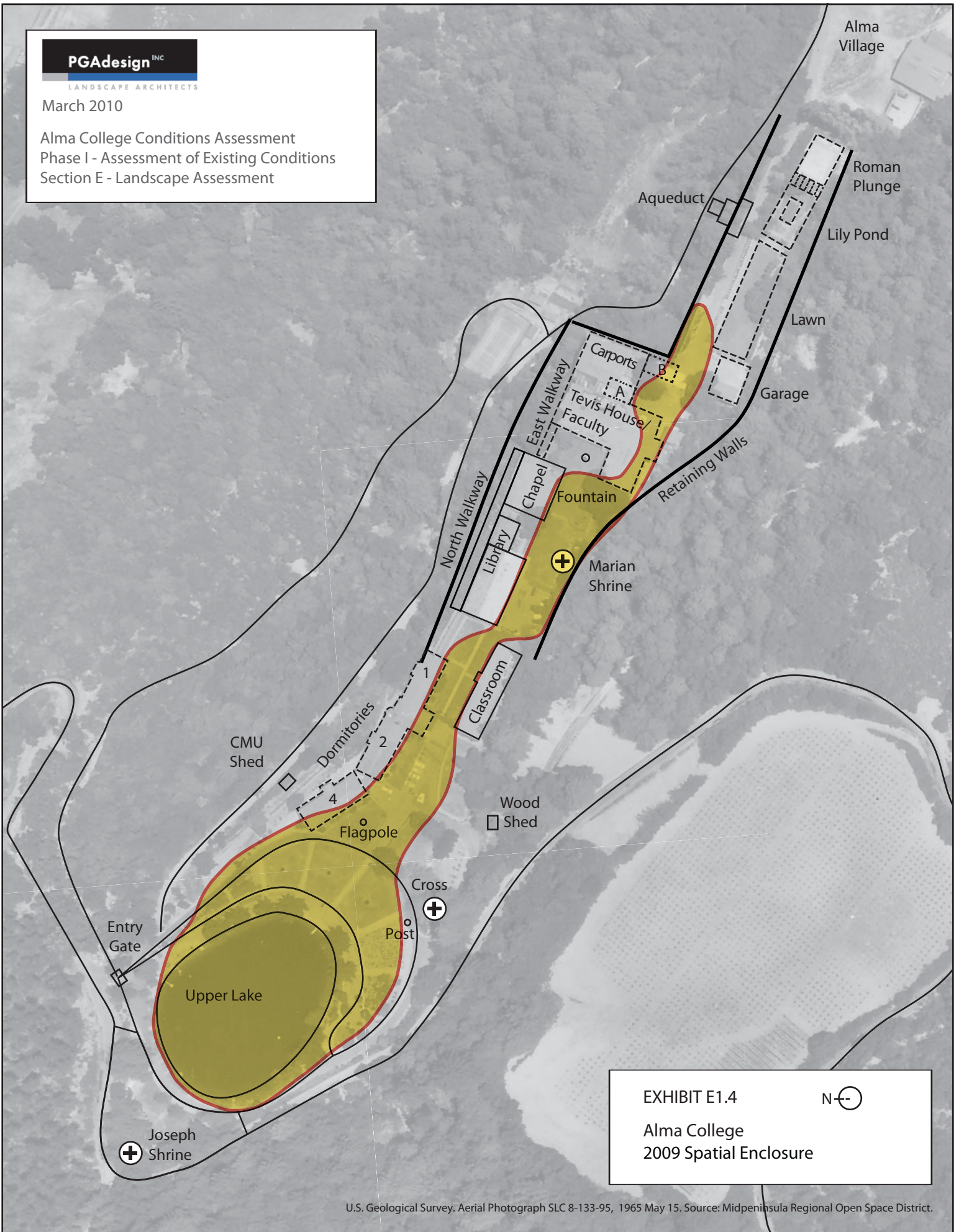

EXHIBIT E1.4



Alma College  
2009 Spatial Enclosure



March 2010

Alma College Conditions Assessment  
Phase I - Assessment of Existing Conditions  
Section E - Landscape Assessment

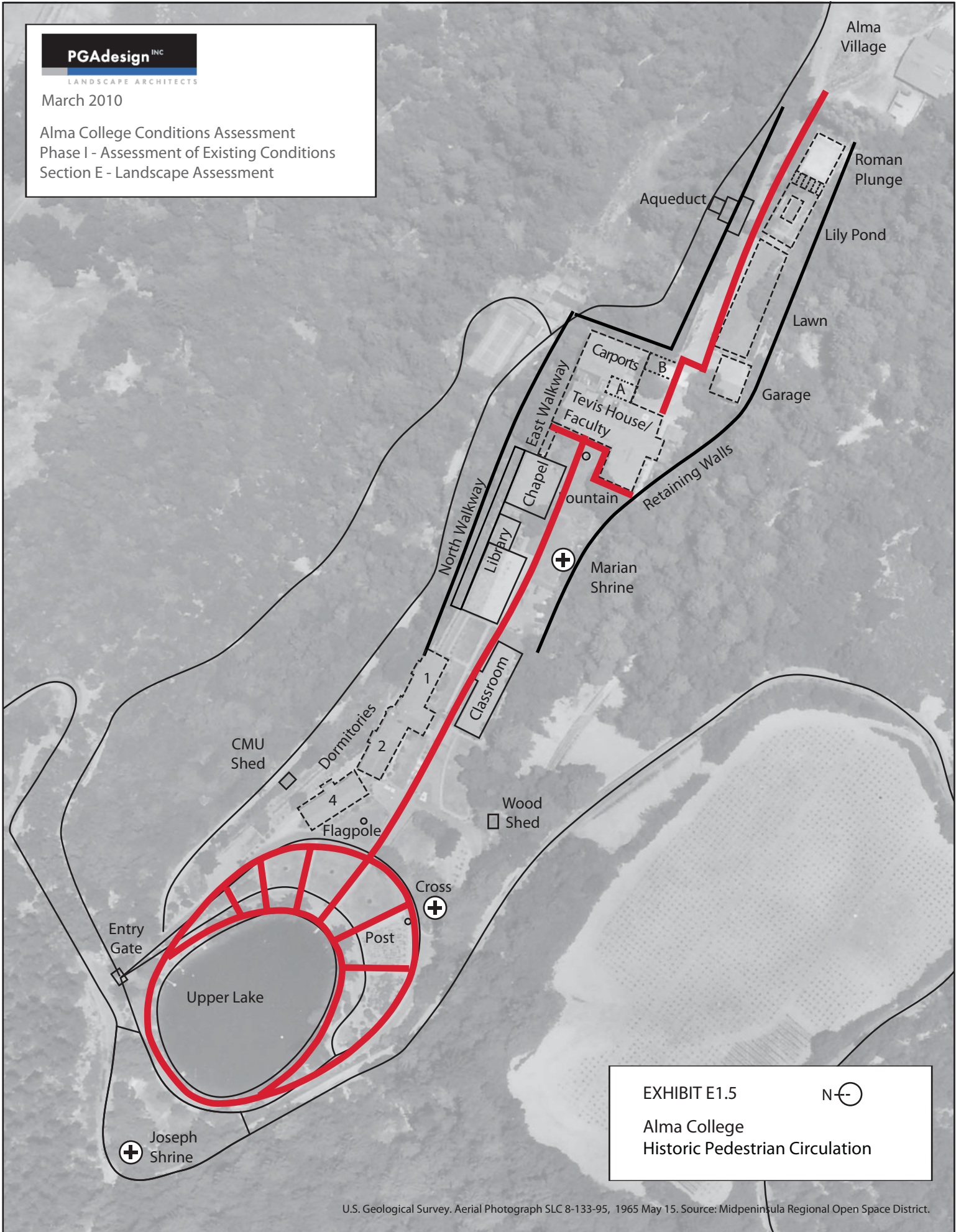

EXHIBIT E1.5      N ↯

Alma College  
Historic Pedestrian Circulation

U.S. Geological Survey. Aerial Photograph SLC 8-133-95, 1965 May 15. Source: Midpeninsula Regional Open Space District.



March 2010

Alma College Conditions Assessment  
Phase I - Assessment of Existing Conditions  
Section E - Landscape Assessment

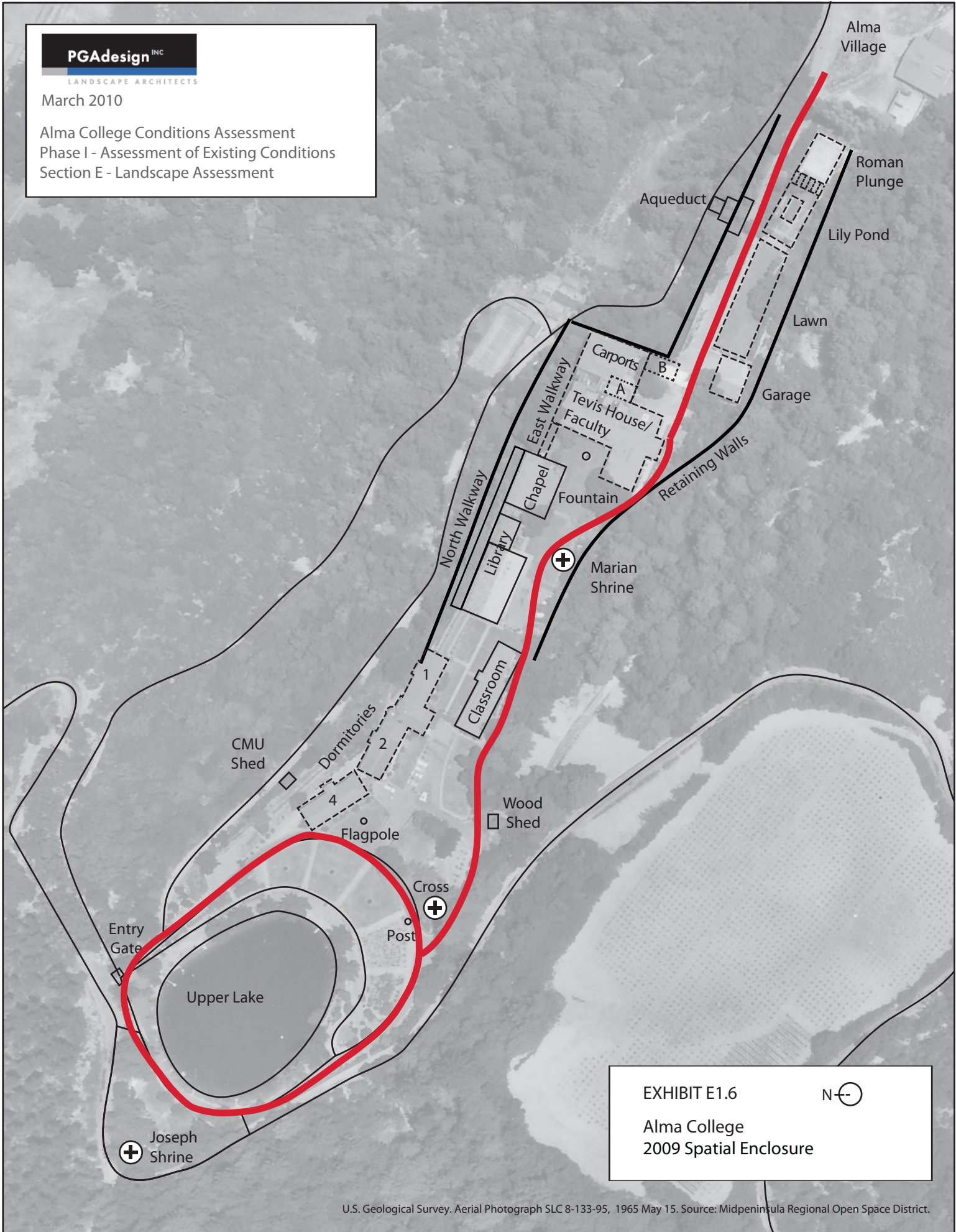

EXHIBIT E1.6



Alma College  
2009 Spatial Enclosure





1. Aerial view of the upper lake end of campus with pedestrian circulation visually prominent.



2. Oblique aerial view looking up the central pedestrian "spine" of campus. The view is contained at the southeast end by the faculty house/Tevis mansion.



3. View of the lawn/lily pond/Roman plunge and the mansion.



4. View of campus from the southwest; an array of buildings stretched out along a flat topped ridgeline with central circulation "spine".



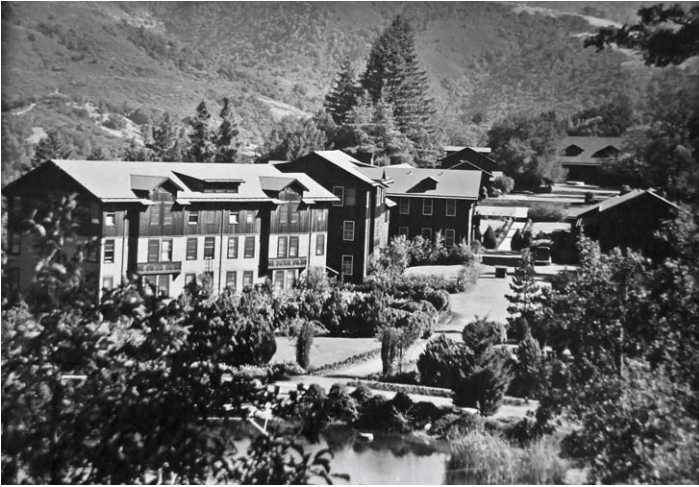

5. Buildings and vegetation enclosed the central space of the Jesuit campus.



6. Jesuit period view looking along the central pedestrian "spine" towards upper lake.



7. View of the stairs up to the lily pond, to trellis/peristyle, the Roman plunge is beyond. Note retaining walls on both sides.



8. View across the lily pond with the still extant semi-circular brick wall to the far right.





9. Jesuit period view looking along the central pedestrian "spine" towards the faculty house/Tevis mansion. This photo predates the substantial library addition.



10. Upper lake with St. Joseph's shrine in the upper corner and formal radial circulation leading to the main part of campus.



11. View over the lawn to the elevated lily pond and trellis/peristyle. Note flanking trees and generous areas of open space.



12. Aerial view of Tevis mansion/faculty house with aqueduct viewed from the northeast.



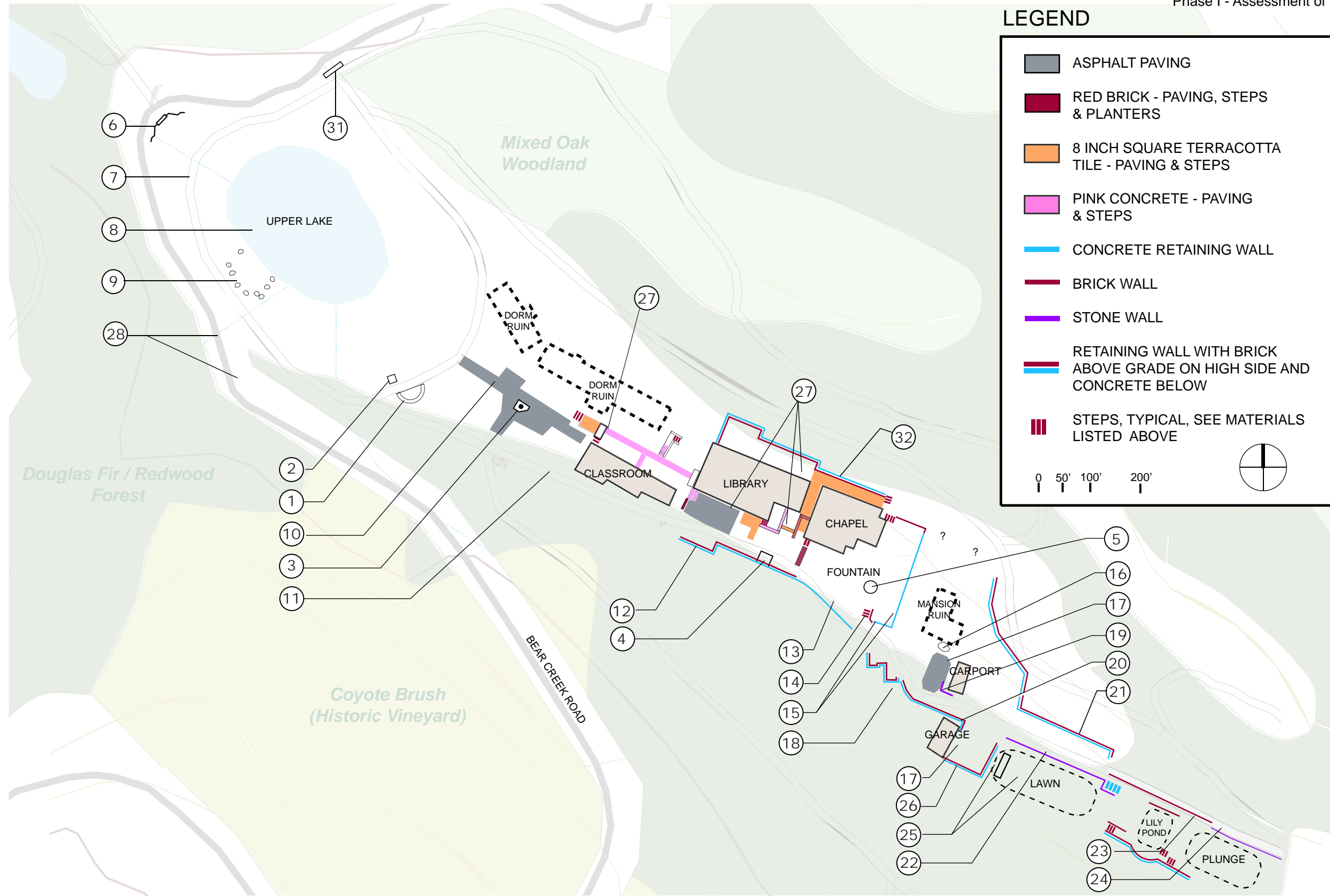

# ALMA COLLEGE SITE ASSESSMENT LANDSCAPE FEATURES PLAN





<b>LANDSCAPE FEATURES: Survey of Conditions</b>			
	<i>Feature</i>	<i>Condition</i>	<i>Character Defining</i>
1)	Cross with semi-circular hedge of Buxus japonica: 60' wide, cross +/-12-ft high. Log cross set in 30" high square concrete base. The semi-circle has a backdrop of blue weeping conifers fronted by the Buxus hedge. The semi-circle faces NW towards the former walk, now drive.	+/- 85% of hedge is present. Colonization within semi-circle of Lonicera, Blackberry, Baccharis, C5 Cherry, Oak. See sketch plan, Item L1.	Yes
2)	Wood Post: Shaped top. Set in ground 8x8, 33" height. Posts appear as path and drive markers in photographs of the Jesuit period.	Fair. Few markers remain. Top was originally painted white.	Yes
3)	Flagpole: Wood with sphere at top. Curb at base. 4-sided raised area, not rectangular.	Fair. Originally white-painted, condition of paint is deteriorated and flaking. Asphalt paving surrounds curbed base.	Yes
4)	Marian Shrine: Square 8' x 8' structure. Wood posts are 8x8 located at the corners, and have brick bases. Brick pedestal centered under the roof is 20" x 20", approx. 36" high. The floor is pink concrete. Rear posts are supported on part of a more extensive brick retaining wall, rather than on brick bases as at the front two posts. The shed roof is wood shingled. The structure is heavily covered with Lonicera and Poison Oak. The shrine is flanked by a pair of pencil conifers.	Fair to good. Some broken brickwork. Wood posts, roof structure and roofing weathered but intact.  Concrete floor = good condition.  See sketch plan, Item L4.	Yes
5)	Fountain Basin: +/- 8' diameter circular made of concrete, with +/- 12" concrete base beyond. The sides and rim of the basin are ornamented by 22" high at rim. Prior to the extant concrete base and flush with grade, there was a brick header course that sat one brick higher than adjacent lawn level.	Poor.  +/- 20% of rim is broken also at the fill/drain line. A further 30% is damaged but not missing.	Yes
6)	St. Joseph's Shrine: Bilaterally symmetrical walled shrine with integral plinth set in front of central wall, flanked by two side walls, with a level cleared area in front. The rear center wall is +/- 11-ft in height, of roughly coursed stone with a brick centerpiece panel, medallion and 30" high brick plinth; the top of center wall is curved. It is flanked on each side by a curved stone wall set 3-ft in front of center wall. The floor is concrete. The flanking stone walls are 6'-6" high at their tallest and step down on each side as they become more distant from the center. The approach to the shrine is terraced with the lower and upper terraces separated by a set of brick steps and a roughly semi-circular graded bank; the terraces are generally level. Along the nearby drive are trees of Liquidamber styraciflua (Liquidambar). Many young saplings have invaded the lower, formerly clear, terrace. Originally sited to be visually connected to Upper Lake. In front of the flanking walls and near the plinth are the remnants of a pair of Taxus sp. (Yews) 4-5-ft in height, now dead.	Brick and Stonework are in good condition. 1 corner cap brick missing from 1 side wall. 2 cracks in concrete floor. Flanking Conifers dead, missing, or failing.  Graded slope and brick stairs are in good condition. View to lake almost obscured by Liquidamber styraciflua saplings. Path to and from stair absent.  See sketch plan, Item L6.	Yes
7)	Drive around Lake: Originally asphalt. Much now duff covered. No curbs. East side several layers of asphalt. Broken and colonized by plants in places. Southeast section near Cross is gravel +/- 12' wide.	Varies. Mostly stable. On west side, the condition is good. On east side, several layers of asphalt are built up with significant surface failure and the condition is Poor to Fair. The gravel section is in good condition.	Yes

<b>LANDSCAPE FEATURES: Survey of Conditions</b>			
	<i>Feature</i>	<i>Condition</i>	<i>Character Defining</i>
8)	Upper Lake: Water spout in middle sits +/- 2' or more above the observed waterline (suggesting the lake was observed with a low water level). Reeds and cattails have naturalized around 100% of the lake's shore. On the Northeast side of the lake is an raised cylindrical concrete utility vault approx. 3' diameter, 6' high possibly serving as a pump vault for the spray jet. On the West side is a square concrete pad/lid 2' by 2' that may house the valve from the water supply from a higher elevation.	Fair. Lake appears to be relatively similar in size to its size during the Jesuit period, though some siltation may have occurred. It is unknown if the jet is functional. The shore line has been heavily invaded by cattails and reeds.	Yes
9)	Bedrock Mortar Grouping consisting of 7 boulders in the central arc, and 5 in an outer arc. The arcs are facing the lake. A wood bench with back to the lake and a Buxus hedge faces the central arc of boulders. There is a grassy clearing between mortars and the bench. A conspicuously eclectic group of tree species are located in this area including Sequoia giganteum (Gigantic Sequoia), a short-needled pine, Phoenix canariensis (Canary Island Palm). The source of these bedrock mortars remains a question.	Good = Mortars. Ground now rough, presume the area was more tended at one time.  Bench wood = Poor condition.  Hedge = Poor.  See sketch plan, Item L9.	Not known
10)	Asphalt Paved Area with white-painted striping for ball courts, with concrete curbs at edges.	Good to Fair. Minor amount of cracks in asphalt with grasses in cracks. This area previously served as the central entry to the Jesuit campus.	No
11)	Drive along the South side of the campus buildings. Surface material is asphalt in places and gravel in places. Date of installation not known.	Fair to Poor.	No
12)	Brick retaining wall on South side of drive (#11), below grade on the high side it is concrete, above grade on the high side it is brick. Above grade on the high side it is 30" high by 16" wide with a soldier brick cap. The cap is stepped at its ends. On the downslope side there is a steep slope towards Bear Creek. Where the terrain on the South side is steeper the wall steps, in plan view, towards the North. The wall is terminated at its South end with a large brick plinth. Overall length of this wall is approx. 150 feet.	Good. Occasional missing bricks, especially at corners. Visual observation only. Defer to structural-geotech for further commentary on condition. A test pit was excavated at this wall on uphill side.	Yes
13)	Concrete retaining wall connecting at end of the brick wall described above in #12. Like the brick wall adjacent to it, this wall sits approx. 30"-48" above grade on the high side. It is heavily covered in creeping fig and is exposed on its South end where it is broken with tangled rebar exposed. The broken end suggests a section of wall has been removed, possibly to permit the gravel drive through in this location. It is possible there was not through circulation in this location originally. Overall length of this wall is approx. 30-ft.	Fair but much of the wall is not visible due to vegetation coverage. Poor condition where cut down to ground for drive.	Yes
14)	Brick Stair leading from fountain level at Library to drive level approaching mansion motor court level.	Fair, though 1 side wall is missing at the stair. The other side wall is brick and in good condition except a couple missing cap bricks at center of coping.	Yes

<b>LANDSCAPE FEATURES: Survey of Conditions</b>			
	<i>Feature</i>	<i>Condition</i>	<i>Character Defining</i>
15)	Brick retaining wall at the edge of the stair described in #14; it turns the corner and after +/- 10' becomes a concrete retaining wall. Overall length is +/- 60-ft. The concrete retaining wall turns to form edge of the mansion motor court and is +/- 14-ft tall in this location. A test pit was excavated on southwest corner of this wall. Downhillside length facing mansion +/- 100-ft long.	One large displacement at the concrete wall at its corner. Defer to structural review otherwise.  Vertical cracks with displacement at the concrete wall facing the mansion.	Yes
16)	Boulder at mansion ruin, backed by brick wall.	Good.	Yes
17)	Asphalt paving at the South side of the mansion	Poor. 75% - 90% covered in vegetation colonizing cracks.	No
18)	Brick retaining wall over concrete retaining wall base with brick stair located across the drive, opposite the parking court of mansion. The brick walls above grade on the high side of the retaining wall has a pile of concrete rubble within it. The Eastern area defined by the brick retaining wall is 20' x 12'; the Western area defined by the brick wall is 12' x 12', between the two is a stair that measures 10' x 5'. On the slope below, there are multiple brick walls that step down the slope. Brick coping to retaining wall is +/- 60' long and leads from the Eastern brick enclosed area towards the East.	The retaining wall is in Fair to Poor condition; see structural assessment.  The stair is badly heaved and is in Poor condition. Its side wall is missing bricks from the coping; some treads and risers are not visible, possibly buried.  Large pieces of brickwork are broken and lie downslope from the wall and stair.  The brick coping that forms the Southern end of this element is in Fair to Good condition.	Yes
19)	Stone retaining wall with random coursing and mortared joints located near the carport.	Significant vertical cracks. Defer to structural assessment.	Yes
20)	Brick wall above concrete retaining wall near garage.	Poor. Large pieces of brickwork are missing.	Yes
21)	Brick retaining wall above with concrete retaining wall below, located on the mansion side of the drive near carport and over aqueduct.	Fair. Some coping broken.	Yes
22)	Rock retaining curb/wall with random coursing and mortared joints located on the South side of the drive leads from the garage to the South, terminating after turning at the stair to the former elevated area of the Lily Pond/Roman Plunge. It tapers in height from 0"-36", and is approx. 75-ft long. The stair that this rock retaining curb/wall terminates at is made of concrete and is inset from the face of the wall.	Good.	Yes
23)	Brick retaining wall located at South side of drive, leading East from the stair up to the former Lily Pond/Roman Plunge level. 4-ft to 14-ft in height. Approx. 130-ft in length.	Good. Minor damage to coping bricks. Defer to structural assessment.	Yes

<b>LANDSCAPE FEATURES: Survey of Conditions</b>			
	<i>Feature</i>	<i>Condition</i>	<i>Character Defining</i>
24)	Boulder rubble retaining wall, rough random coursing without mortar. There is a significant batter to the wall. This wall is located on the South side of the drive leading to the East from the brick wall in #23. It retains the terrace where the Lily Pond/Roman Plunge was formerly located.	Fair. Significant settlement but generally still retaining the slope.	Yes
25)	Lawn, Lily Pond and Roman Plunge terrace has, at its West end, a Pergola with a single row of brick columns, 16" square +/- 10-ft tall, with a wood trellis consisting of two 3x12s with cross bracing. There are 5 brick columns visible, 10-ft on center, covered in grapevine. Remnant terracing is visible, and there is a remnant semicircular brick over concrete retaining wall that aligns with the former position of the Lily Pond. This 3-part feature (Lawn, Lily Pond, Plunge) sits above the associated retaining walls in #22, #23, #24 above, and has terracotta steps, and a terracotta paved path on the south side of the Plunge. The formerly open lawn terrace has been colonized by Baccharis and grasses to the East of the Pergola. On the South side of the terrace, approx. 60-ft east of the Pergola, there is a retaining wall with brick above the high side of adjacent grade and concrete below. This retaining wall appears to retain grade that creates the flat terrace for these features on South (or creek) side. The Lily Pond, Plunge and associated trellis/peristyle are no longer extant. Blue cedars mark the east end of the Plunge.	The terrace of the former Lilly Pond and Roman Plunge remains in Fair to Poor condition.  The brick columns of the Pergola are in Good condition and the wood elements are in Fair condition.  The Pond and Plunge are missing.  Five timbers are lying on the ground on the drive opposite this area and may have been members of the now-missing pergola that divided the Pond from the Plunge. They are 25-ft long, 12x12s with shaped ends.	Yes, in so far as it remains which is limited.
26)	Brick retaining wall above concrete retaining wall at South and East edge of garage forecourt.	Fair to Good. This element is located in a fenced inaccessible area. Review of condition is not complete.	Yes
27)	Pedestrian circulation within the area of the grouping of campus buildings is made up of a series of pink-colored concrete walks, serving the classroom building and library, and level changes via concrete steps in the same areas or brick steps or terra cotta tile steps in the vicinity of the chapel and East end of the library. At the Northwest end of this area, there is a tile paved remnant of the covered walkway off the North corner of the classroom building and tile paving between the library and chapel.	Fair to Poor.	No, not in its current condition.
28)	Fencing throughout the site consists of wood post and rail fence along Bear Creek Road and at perimeter locations and contemporary pressure-treated posts with wire fencing along the South side of Upper Lake and in locations where the Open Space District limits access to the Alma College site.	Post and rail fence is in Poor condition.  Pressure-treated posts with wire fencing are in Good condition.	No



<b>LANDSCAPE FEATURES: Survey of Conditions</b>			
	<i>Feature</i>	<i>Condition</i>	<i>Character Defining</i>
29)	For a survey of vegetation see the "Alma College Ornamental Plant Resource Inventory" prepared by Keith Park 7.22.09. In summary the species on the plateau where the primary campus buildings are located are dominated by introduced ornamental trees and shrubs. Some are addressed in the items above. The majority of species seen from paths at a lower elevation than this plateau are predominantly native species with a limited number of escaped ornamentals. Generally, there is a rich preponderance of large conifers.	Trees that have low water use requirements or are in close proximity to Upper Lake appear to be well established and many are very large, such as the Blue Atlas Cedars, Weeping Blue Atlas Cedars, and Western and Eastern Red Cedars at the Cross with Semi-circular hedge. Based on a review of available historic photographs a significant number of species and plants have been lost from the site. This is likely due to lack of regular watering and maintenance.	Yes, in so far as it remains.
30)	Site grading and terraces predominate within the immediate environs of the campus buildings. At the North West end of the site, there was grading to establish Upper Lake; moving along the spine of the site, terraces were established at the flagpole area, on the North side of the classroom building, on the South side of the library, and the South side of the chapel. A significant level change lies between the chapel and the parking court level of the mansion, and a terrace was created at the Lily Pond/Roman Plunge. These flat spaces, and those occupied by the buildings themselves, were created by the construction of substantial walls on each side of this spur landform.	Fair to Good. The grading is predominantly still intact.	Yes
31)	Entry Gates BC04: Flanked on each side by adobe style concrete block, 14-ft long by 3'-4" wide, 4-ft tall with elevated plinths at each end. 6-ft tall associated wood fencing and metal gates.	Approx 25% of coping block is broken. The remainder of the block work and gate is in Good condition.  All in Good condition. Dates to Open Space District period.	No
32)	Brick wall above concrete retaining wall on north side of library.	Upper wall good; lower wall has rotated away from the upper wall and is in poor condition.	Yes



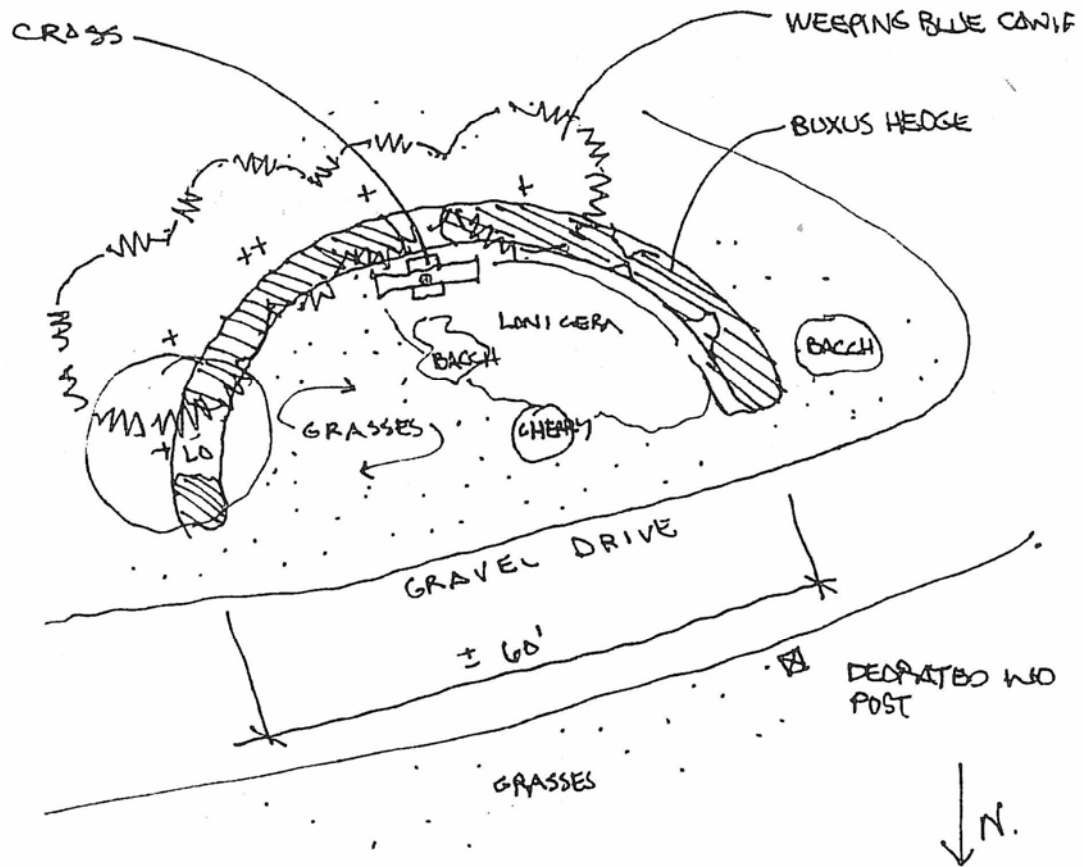

ITEM	CROSS W/	SEMI-CIRCULAR HEDGE	7.2.D9
L1	N.T.S.		

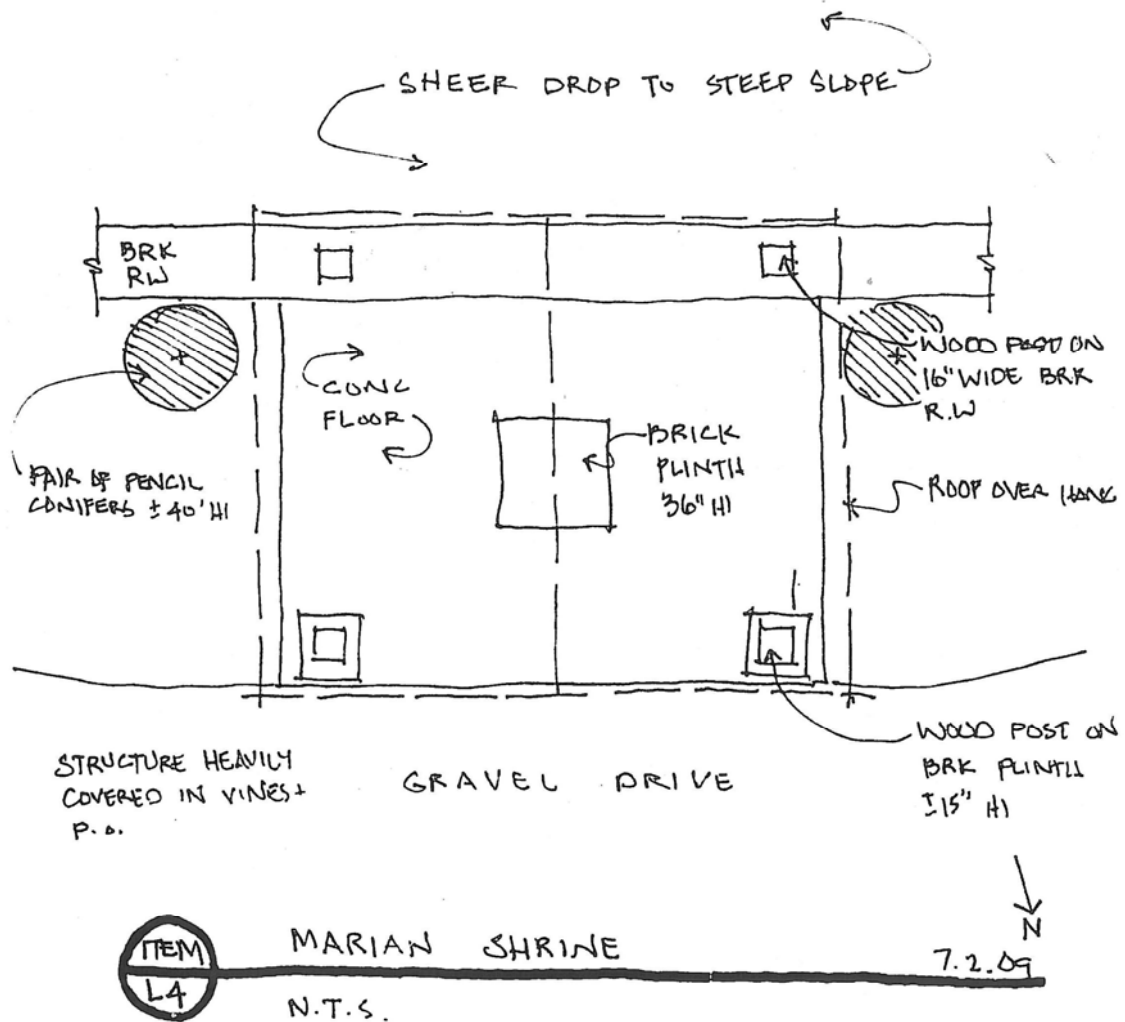



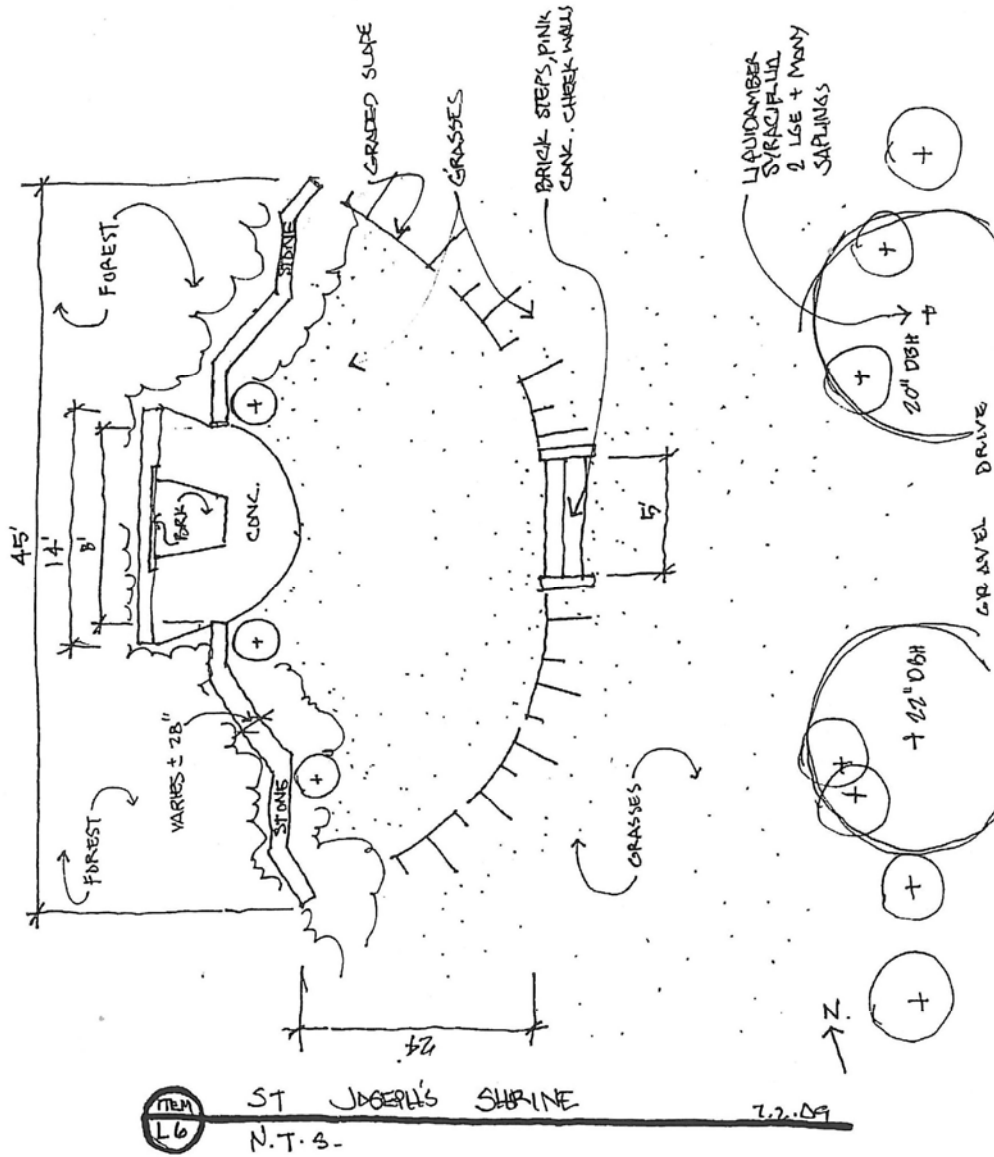

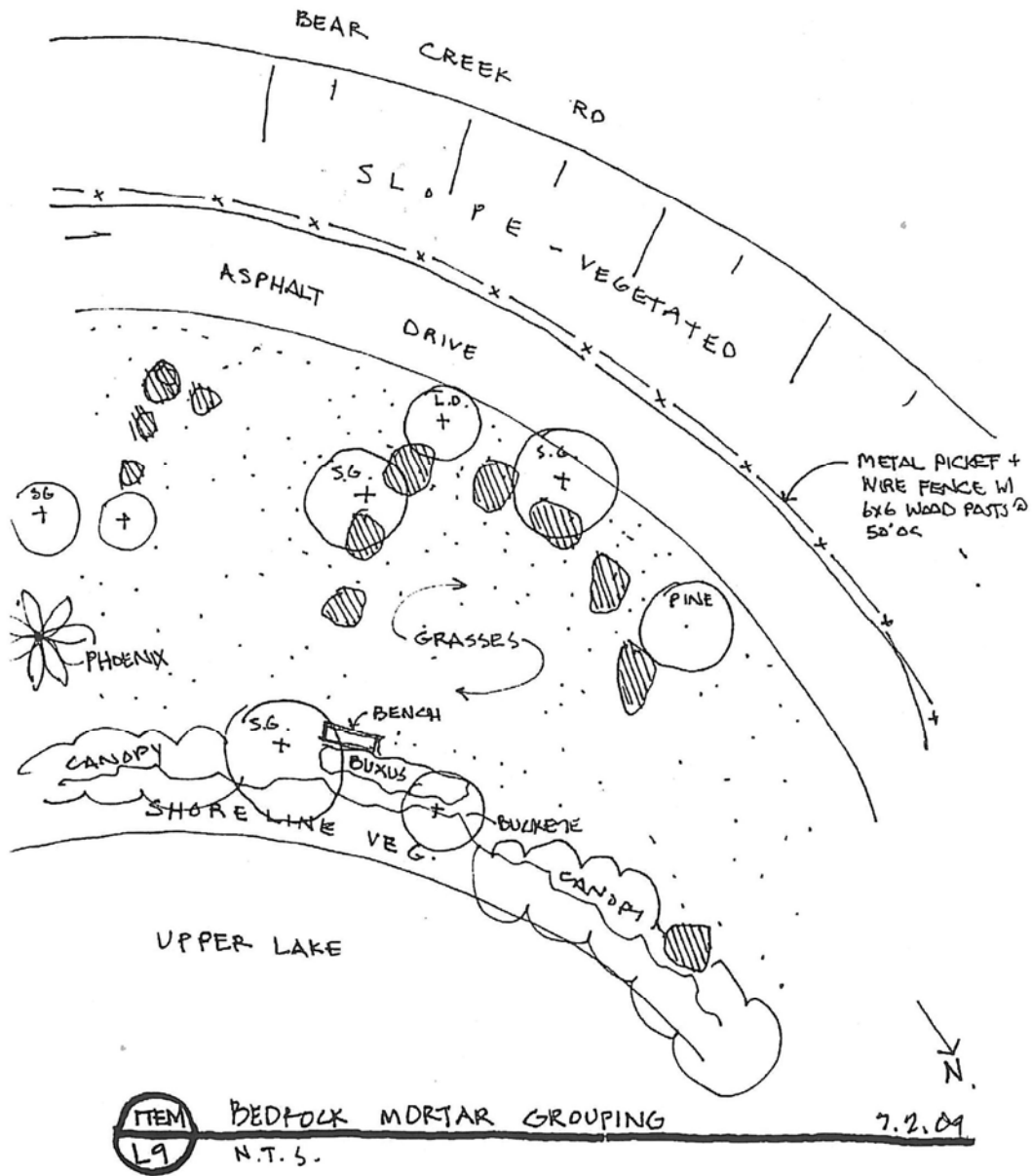



*Item 1 090701 Cross with hedge*



*Item 1 090701 Cross with hedge*



*Item 1 090701 Cross with hedge*



*Item 1 090701 Cross with hedge*



*Item 2 090701 Shaped wood post*



*Item 2 090701 Shaped wood post*



*Item 2 090701 Shaped wood post*



*Item 3 090701 Flagpole 001.jpg*

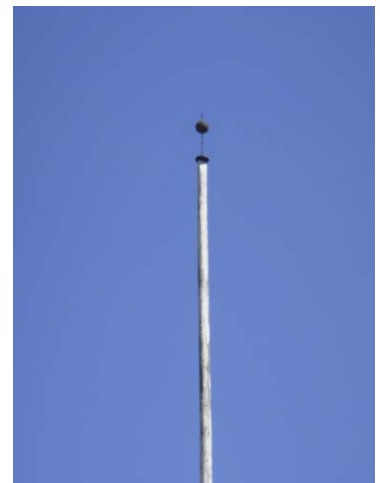

*Item 3 090701 Flagpole 002.jpg*





Item 3 090701 Flagpole 003.jpg



Item 4 090701 Marian Shrine 001.jpg



Item 4 090701 Marian Shrine 002.jpg



Item 4 090701 Marian Shrine 003.jpg



Item 4 090701 Marian Shrine 004.jpg



Item 4 090701 Marian Shrine 005.jpg



Item 4 090701 Marian Shrine 006.jpg



Item 4 090701 Marian Shrine 007.jpg

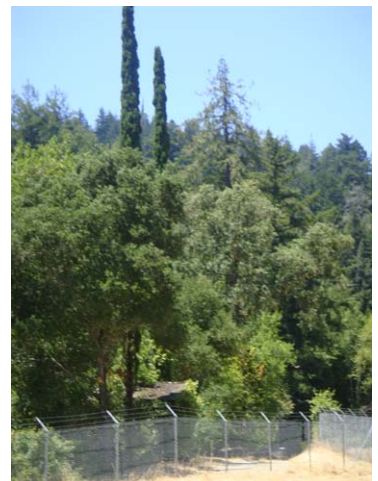

Item 4 090701 Marian Shrine 008.jpg





Item 4 090701 Marion shrine 009.jpg



Item 5 090701 Fountain Basin 001.jpg



Item 5 090701 Fountain Basin 002.jpg



Item 5 090701 Fountain Basin 003.jpg



Item 5 090701 Fountain Basin 004.jpg



Item 5 090701 Fountain Basin 005.jpg



Item 5 090701 Fountain Basin 006.jpg



Item 5 090701 Fountain Basin 007.jpg



Item 5 090701 Fountain Basin





*Item 6 090701 St Josephs Shrine*



*Item 6 090701 St Josephs Shrine*



*Item 6 090701 St Josephs Shrine*



*Item 6 090701 St Josephs Shrine*



*Item 6 090701 St Josephs Shrine*



*Item 6 090701 St Josephs Shrine*



*Item 6 090701 St Josephs Shrine*



*Item 6 090701 St Josephs Shrine*



*Item 6 090701 St Josephs Shrine*





*Item 6 090701 St Josephs Shrine*



*Item 6 090701 St Josephs Shrine*



*Item 6 090701 St Josephs Shrine*



*Item 6 090701 St Josephs Shrine*



*Item 8 090701 Upper Lake 001.jpg*



*Item 8 090701 Upper Lake 002.jpg*



*Item 8 090701 Upper Lake 003.jpg*



*Item 8 090701 Upper Lake 004.jpg*



*Item 8 090701 Upper Lake 005.jpg*





*Item 9 0904xx Bedrock mortar*



*Item 9 0904xx Bedrock mortar*



*Item 9 0904xx Bedrock mortar*



*Item 9 090701 Bedrock mortar*



*Item 9 090701 Bedrock mortar*



*Item 9 090701 Bedrock mortar*



*Item 9 090701 Bedrock mortar*



*Item 9 090701 Bedrock mortar*



*Item 9 090701 Bedrock mortar*





*Item 9 090701 Bedrock mortar*



*Item 12 0904xx Brick retaining wall*



*Item 12 0904xx Brick retaining wall on*



*Item 14 090701 Brick stair from*



*Item 14 090701 Brick stair from*



*Item 14 090701 Brick stair from*



*Item 14 090701 Brick stair from*



*Item 15 090701 Concrete retaining*



*Item 15 090701 Concrete retaining*





*Item 15 090701 Concrete retaining*



*Item 16 090701 Boulder at mansion*



*Item 16 090701 Boulder at mansion*



*Item 18 090701 Brick retaining wall*



*Item 18 090701 Brick retaining wall*



*Item 18 090701 Brick retaining wall*



*Item 18 090701 Brick retaining wall*



*Item 18 090701 Brick retaining wall*

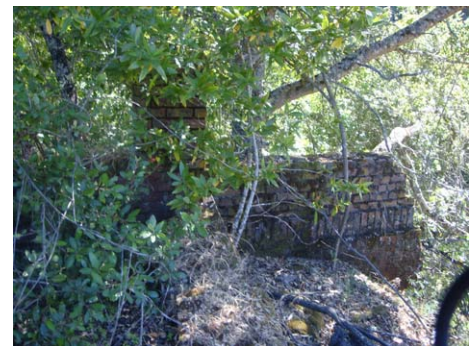

*Item 18 090701 Brick retaining wall*





*Item 18 090701 Brick retaining wall*



*Item 19 090701 Stone retaining wall*



*Item 19 090701 Stone retaining wall*



*Item 19 090701 Stone retaining wall*



*Item 19 090701 Stone retaining wall*



*Item 19 090701 Stone retaining wall*



*Item 20 090701 Brick retaining wall on*



*Item 21 090701 Brick retaining wall SE*



*Item 21 090701 Brick retaining wall SE*





*Item 21 090701 Brick retaining wall SE*



*Item 21 090701 Brick retaining wall SE*



*Item 22 0904xx Rock retaining*



*Item 22 090701 Rock retaining*



*Item 22 090701 Rock retaining*



*Item 22 090701 Rock retaining*



*Item 22 090701 Rock retaining*



*Item 22 090701 Rock retaining*

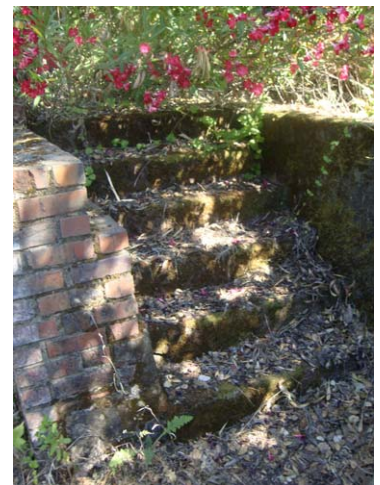

*Item 22 090701 Stair at rock retaining*





*Item 23 090701 Brick retaining wall*



*Item 23 090701 Brick retaining wall*



*Item 23 090701 Brick retaining wall*

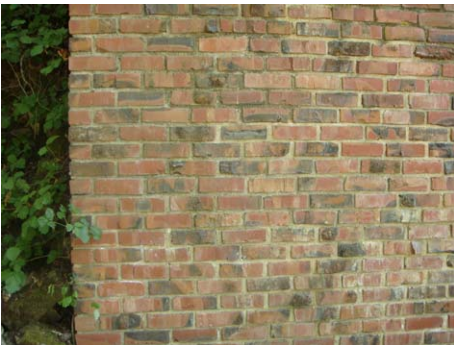

*Item 23 090701 Brick retaining wall*



*Item 23 Brick retaining wall at site*



*Item 24 090701 Boulder rubble*



*Item 24 090701 Boulder rubble*



*Item 25 090701 Lily Pond and Roman*



*Item 25 090701 Lily Pond and Roman*





*Item 25 090701 Lily Pond and Roman*



*Item 25 090701 Lily Pond and Roman*



*Item 25 090701 Lily Pond and Roman*



*Item 25 090701 Lily Pond and Roman*



*Item 25 090701 Lily Pond and Roman*



*Item 25 090701 Lily Pond and Roman*



*Item 25 090701 Lily Pond and Roman*



*Item 25 090701 Lily Pond and Roman*



*Item 25 090701 Lily Pond and Roman*





*Item 25 090701 Lily Pond and Roman*



*Item 26 090701 Brick retaining wall*



*Item 27 090701 Ped circulation near*



*Item 27 090701 Ped circulation near*



*Item 27 090701 Ped circulation near*



*Item 27 090701 Ped circulation near*



*Item 27 090701 Ped circulation near*



*Item 27 090701 Ped circulation near*



*Item 27 090701 Ped circulation near*





*Item 27 090701 Ped circulation near*



*Item 27 090701 Ped circulation near*



*Item 27 090701 Ped circulation near*



*Item 27 090701 Ped circulation near*



*Item 27 090701 Ped circulation near*



*Item 27 090701 Ped circulation near*



*Item 27 Ped circulation near campus*



*Item 27 Ped circulation near campus*



*Item 27 Ped circulation near campus*





*Item 28 090701 Site fencing 001.jpg*



*Item 28 090701 Site fencing 002.jpg*



*Item 28 090701 Site fencing 003.jpg*



*Item 28 090701 Site fencing 004.jpg*



*Item 28 090701 Site fencing 005.jpg*



*Item 28 090701 Site fencing 006.jpg*



*Item 28 090701 Site fencing 007.jpg*



*Item 31 090701 Entry gates 001.jpg*



*Item 31 090701 Entry gates 002.jpg*





*Item 31 090701 Entry gates 003.jpg*



*Item 31 090701 Entry gates 004.jpg*



*Item 31 090701 Entry gates 005.jpg*



*Item 31 090701 Entry gates 006.jpg*



*Item 31 Entry Gates 090701 007.jpg*



*Item 32 090701 Brick Wall 009.jpg*



*Item 32 090701 Brick Wall 013.jpg*



*Item 32 090701 Brick Wall 016.jpg*

Exhibit E-7. Alma College Ornamental Plant Resource Inventory  
(Park, Keith W. "Alma College Ornamental Plant Resource Inventory," Alma  
College volunteer horticulturalist, 22 July 2009.)





Alma College  
Ornamental Plant Resource Inventory

Compiled by Keith Park  
7/22/09

Area Name	Number of Plant Resources
Parking Area	16
Saint Joseph Shrine	10
Pond Road	21
Bedrock Mortar Rock Ring	9
Wooden Cross & Flagpole	11
Classroom and Library Buildings	11
Marian Shrine and Wall	4
Roman Plunge	24
Blue Atlas Cedar Grove	12
Road Below House	20
<b>Total Count</b>	<b>138</b>

### Parking Area

Botanical Name	Common Name	Quantity	Map #
<i>Buxus</i> spp.	Boxwood	1	1
<i>Cedrus deodara</i>	Deodar Cedar	2	2a,b
<i>Cinnamomum camphora</i>	Camphor Tree	1	3
<i>Crataegus</i> (possibly <i>C. laevigatum</i> )	Hawthorn	1	4
<i>Liquidamber styraciflua</i>	Sweet Gum	1	5
<i>Prunus laurocerasus</i>	English Laurel	2	6a,b
<i>Sequoiadendron giganteum</i>	Giant Sequoia	3	7a-c
<i>Spirea cantoniensis</i> 'Flore Pleno'	Double Reeve's Spirea	5	8a-e

### Saint Joseph Shrine

Botanical Name	Common Name	Quantity	Map #
<i>Abelia grandiflora</i>	Abelia	1	9
<i>Crataegus</i> (possibly <i>C. pubescens</i> )	Mexican Hawthorne	1	10
<i>Hedera helix</i>	English Ivy	1	11
<i>Liquidamber styraciflua</i>	Sweet Gum	3	12a-c
<i>Platyclusus (Thuja) orientalis</i>	Oriental Thuja	1	13
<i>Quercus kelloggii</i>	Black Oak	2	14a,b
<i>Sequoiadendron giganteum</i>	Giant Sequoia	1	15

### Pond Road

Botanical Name	Common Name	Quantity	Map #
<i>Cinnamomum camphora</i>	Camphor Tree	2	16a,b
<i>Cupressus macrocarpa</i>	Monterey Cypress	2	17a,b
<i>Malus domestica</i>	Apple	1	18
<i>Prunus cerasifera</i>	Purple-Leaf Plum	1	19
<i>Prunus laurocerasus</i>	English Laurel	4	20a-d
<i>Rosa</i> 'Felicite et Perpetue'	Felicite et Perpetue Rose	2	21a,b
<i>Rosa</i> spp.	Rose	6	22a-f

### Bedrock Mortar Rock Ring

Botanical Name	Common Name	Quantity	Map #
<i>Taxus baccata</i> 'Fastigiata'	Irish Yew	3	23a-c
<i>Buxus</i> spp.	Boxwood	1 hedge	24
<i>Juniperus virginiana</i>	Eastern Redcedar	1	25
<i>Phoenix canariensis</i>	Canary Island Date Palm	1	26
<i>Prunus cerasifera</i>	Purple-Leaf Plum	1	27
<i>Rosa</i> 'Felicite et Perpetue'	Felicite et Perpetue Rose	1	28
<i>Sequoiadendron giganteum</i>	Giant Sequoia	4	29a-d



### Wooden Cross & Flagpole

Botanical Name	Common Name	Quantity	Map #
<i>Abies</i> spp.	Fir Tree	1	30
<i>Cedrus atlantica</i> 'Glauca'	Blue Atlas Cedar	1	31
<i>Cedrus atlantica</i> '?' (Unusually columnar form with pendant branches)	"Weeping" Blue Atlas Cedar	1	32
<i>Juniperus chinensis</i>	Juniper	2 hedges	33a,b
<i>Juniperus virginiana</i>	Eastern Redcedar	2	34a,b
<i>Taxus baccata</i> 'Fastigiata'	Irish Yew	2	35a,b
<i>Thuja plicata</i>	Western Red Cedar	2	36a,b

### Classroom and Library Buildings

Botanical Name	Common Name	Quantity	Map #
<i>Aloe striatula</i>	Coral Aloe	2 clumps	37a,b
<i>Arbutus unedo</i>	Strawberry Tree	1	38
<i>Ficus pumila</i>	Creeping Fig	1	39
<i>Fuschia hybrida</i>	Fuschia	2	40a,b
<i>Hedera</i> spp.	Ivy	2	41a,b
<i>Parthenocissus quinquefolia</i>	Virginia Creeper	1	42
<i>Platycladus (Thuja) orientalis</i>	Oriental Thuja	1	43
<i>Pyrus communis</i>	Pear	1	44

### Marian Shrine and Wall

Botanical Name	Common Name	Quantity	Map #
<i>Chamaecyparis obtusa</i>	False Cypress	1	45
<i>Cupressus sempervirens</i> 'Stricta'	Italian Cypress	2	46a,b
<i>Ficus pumila</i>	Creeping Fig	1	47

### Roman Plunge

Botanical Name	Common Name	Quantity	Map #
<i>Nerium oleander</i>	Oleander	16+	48a-p
<i>Parthenocissus tricuspidata</i>	Boston Ivy	1	49
<i>Platycladus (Thuja) orientalis</i>	Oriental Thuja	4	50a-d
<i>Sequoiadendron giganteum</i>	Giant Sequoia	1	51
<i>Vitis</i> cv.	Grape	2	52a,b

### Blue Atlas Cedar Grove

Botanical Name	Common Name	Quantity	Map #
<i>Cedrus atlantica</i> 'Glauca'	Blue Atlas Cedar	12	53

### Road Below House

Botanical Name	Common Name	Quantity	Map #
<i>Pinus</i> spp.	Pine Tree	15	54a,b
<i>Prunus cerasifera</i>	Purple-Leaf Plum	1	55
<i>Prunus</i> spp.	Green Leaved Plum	2	56
<i>Vinca major</i>	Periwinkle	drifts	57
<i>Wisteria</i>	Wisteria	1	58

## Notes on Plant Material

Map#	Notes
2	Larger tree = 5'6" dbh; 70' tall. Est. age 80 years.
3	3'9" dbh; 30' tall. Healthy.
4	25' tall. Healthy.
5	5' dbh; 60' tall. Healthy, est. age 80 years.
6	25' tall, moderate health.
7a	Shorter tree, Healthy: 5' dbh; 30' tall. Giant Sequoia's are native to the Sierra Range but not the coast ranges.
7b	Taller tree, poor health: 8' dbh; 60' tall.
8	8 original clumps, only 5 extant, possibly from Tevis period.
9	Healthy specimen, possibly from Jesuit period.
10	30' tall tree w/ large leaves pubescent on underside. Possible root suckers arising from ground next to cultivated specimen.
12	Three trees, all healthy, possibly from Tevis period. Tallest tree = 5' dbh; 100' tall. Numerous seedlings or suckers arising along road edge.
13	Figure 37 of Historic Resource Survey shows four of these shrubs from the Jesuit period. Only one is extant.
14a,b	This tree species is endemic to the mixed hardwood and coniferous forests of the Santa Cruz Mountains and might simply be native vegetation. However the way the two trees are perfectly arranged behind the altar suggests that they were intentionally planted as backdrops.
15	4' dbh; only 30' tall due to severe damage to upper portion of tree.
16	Two specimens, double-trunked. One tree 30' tall and healthy, the other almost dead.
17	Tallest tree 100' tall; 8' dbh.
18	Old tree, possibly seedling, poor condition.
19	Small grove, 30' tall, probably from one or two trees that were either cut down & re-sprouted by suckering. Healthy and fruiting.
20	Four individual shrubs, all about 15' tall, shrubby in habit and healthy.
21	Cultivar identified based on a comparison sample taken from a known specimen surviving in the gardens on Alcatraz Island.
22	Climber/rambler, unknown cultivars.
23	Possibly from Tevis period.
25	2 ½' dbh; 25' tall. Species id based on physical characteristics: branches ascending but tips of branches weeping and pendant.
26	9' dbh; 25' tall.
28	Appears to be same cultivar as #21.
29	Four specimens, between 6-7' dbh; average of 50' tall.
30	Unable to id to species, possibly <i>veitchy</i> . 3' dbh; 60' tall. Pyramidal in shape and moderately healthy.
31	10' dbh; 80' tall. Healthy likely from Tevis period. A second dead tree of same cultivar stands next to the living tree.
32	4 ½' dbh; 60' tall. This tree is unique in form and habit, but clearly a form of Blue Atlas Cedar that has weeping, pendant branches and a columnar habit. Interesting specimen that warrants further identification.
33	One of these Junipers in the hedges that flank the flagpole driveway is an attractive golden cultivar that is distinct from the rest of the Juniper hedge material.
34	6' dbh; 50' tall. Appears to be the same species as #25.
35	Same cultivar as #23.
36	6 ½' dbh; formerly taller but now in poor shape and condition.
43	Same species as #13.
44	2' dbh at branching point; 15' tall. Fruits evident, too early to id cultivar.
45	1 ½' dbh; 25' tall. Id'd as False Cypress based on leaf and bark characteristics, but unable to positively id the cultivar. Attractive tree, probably from Jesuit period.
46	These two trees exhibit all characteristics of an extremely narrow form of the normally columnar Italian Cypress, but positive id on the exact cultivar should be made.

- 48 Counted at least 16 distinct shrubs all along retaining wall. Blooming (scarlet red flowers) but in only moderate health generally. Probably from Jesuit period based on the shrubs being planted right up to top of stairs from driveway.
- 50 Long row of up to 12 plants, now only 4 extant. 15'-20' tall on average, probably from Tevis period.
- 51 Largest example of this species on the property: 12' dbh; 80 tall. Probably at least 100 years old.
- 52 Two individual grape vines growing on arbor, unknown cultivar.
- 53 Average of 5' dbh and 80' tall. Two distinct groves of up to 6 individual trees per grove, clearly situated to frame the axis of the Roman Plunge space.





# St. Joseph's Shrine and Picnic Area

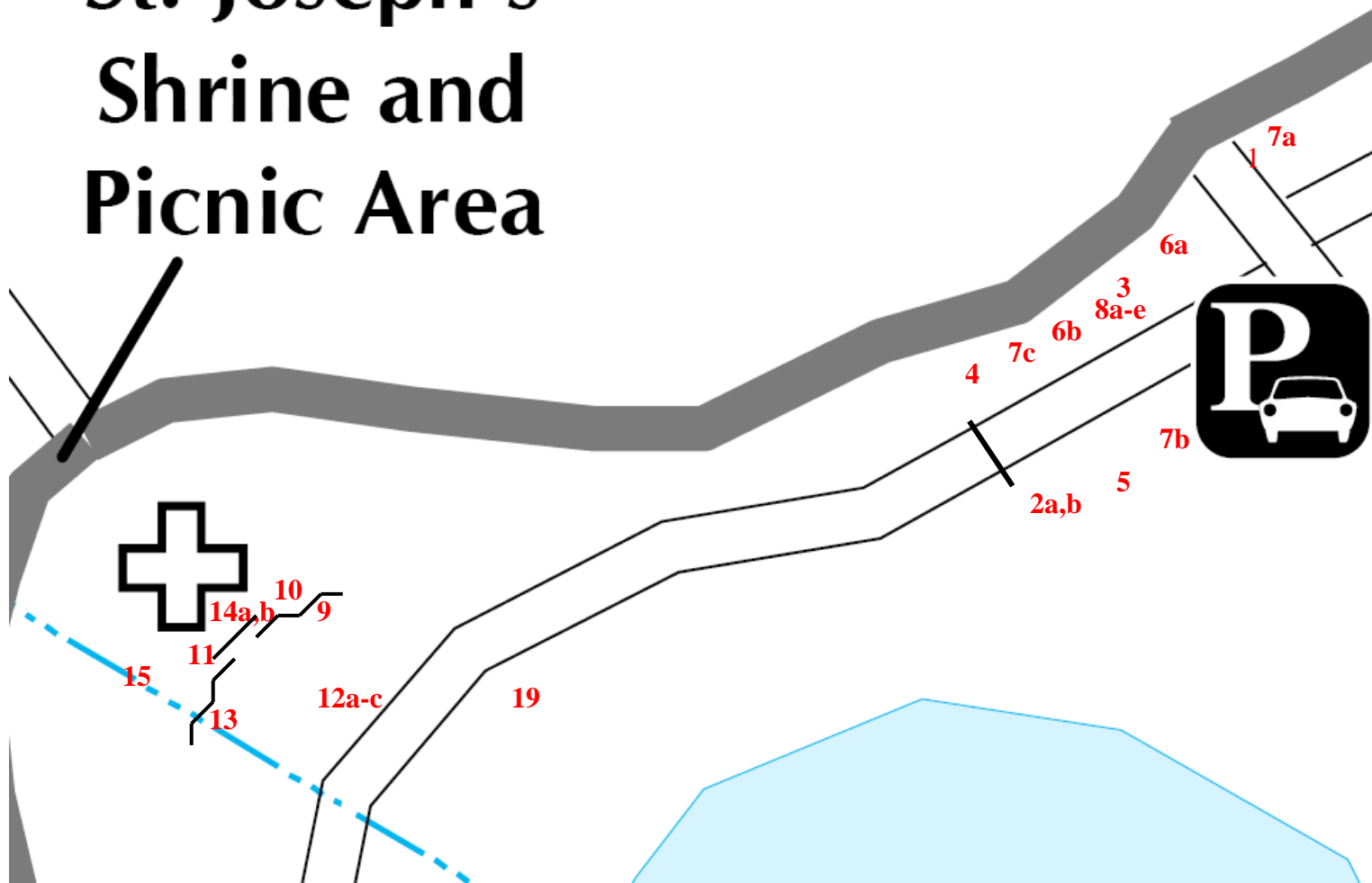

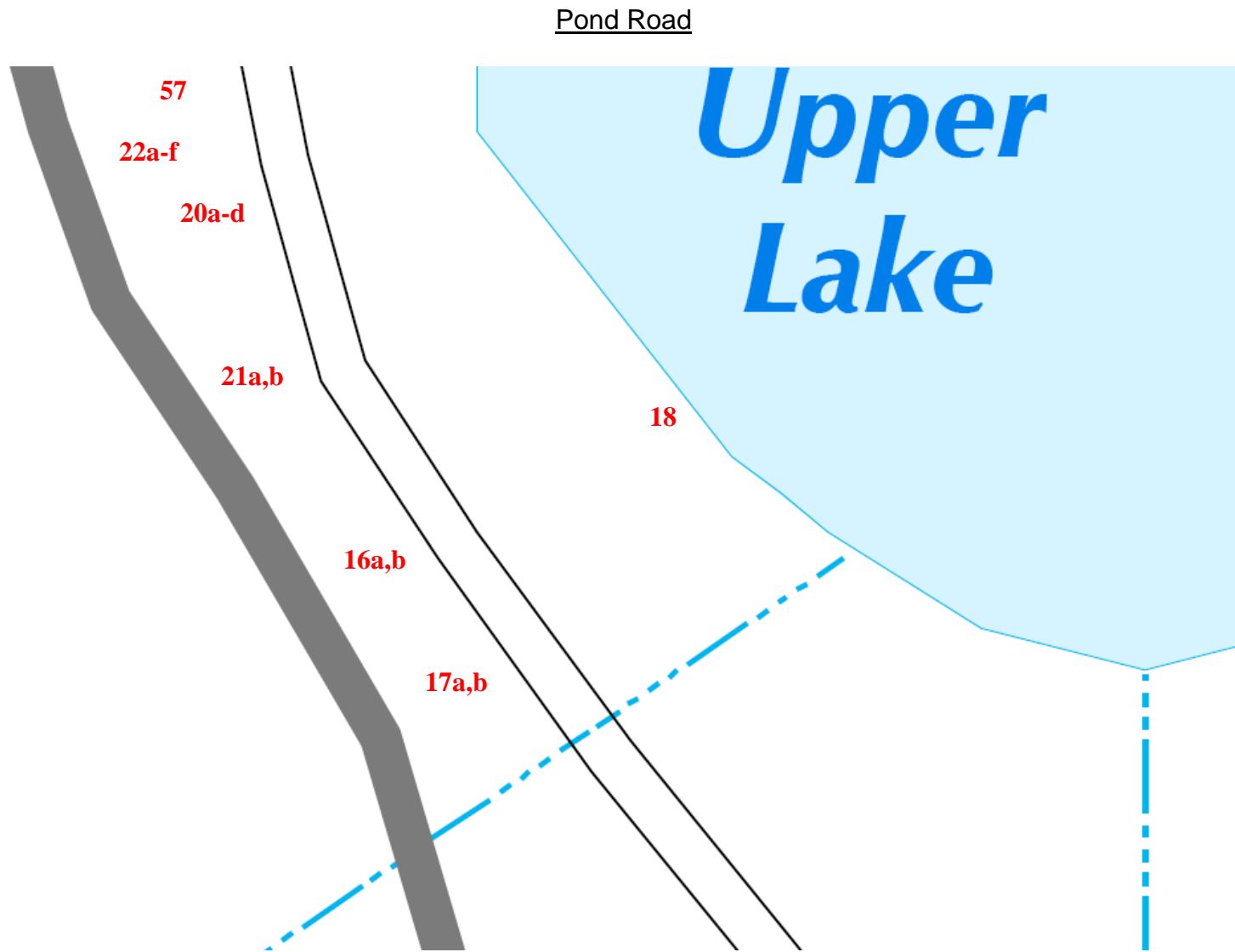

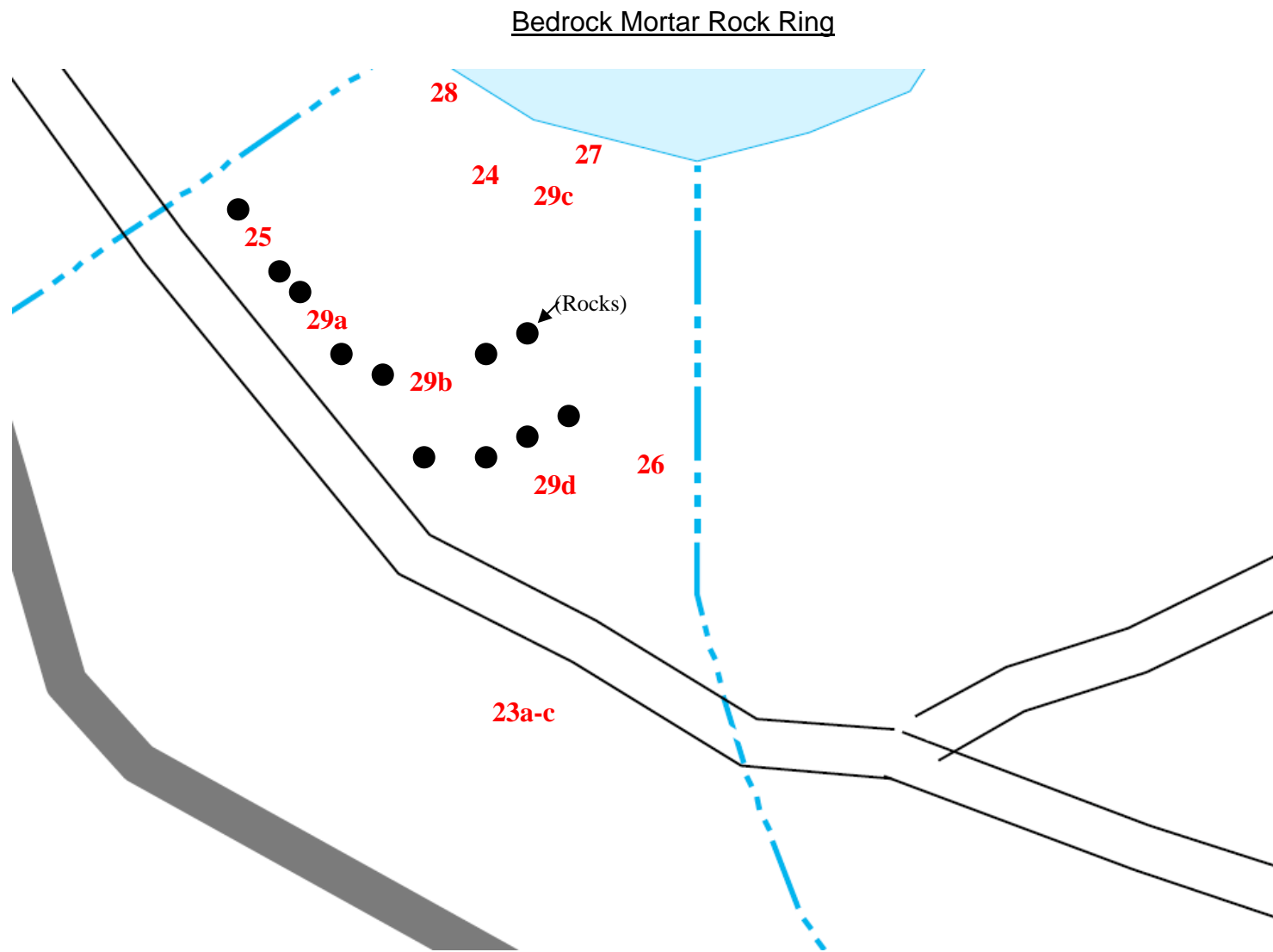



Wooden Cross & Flagpole

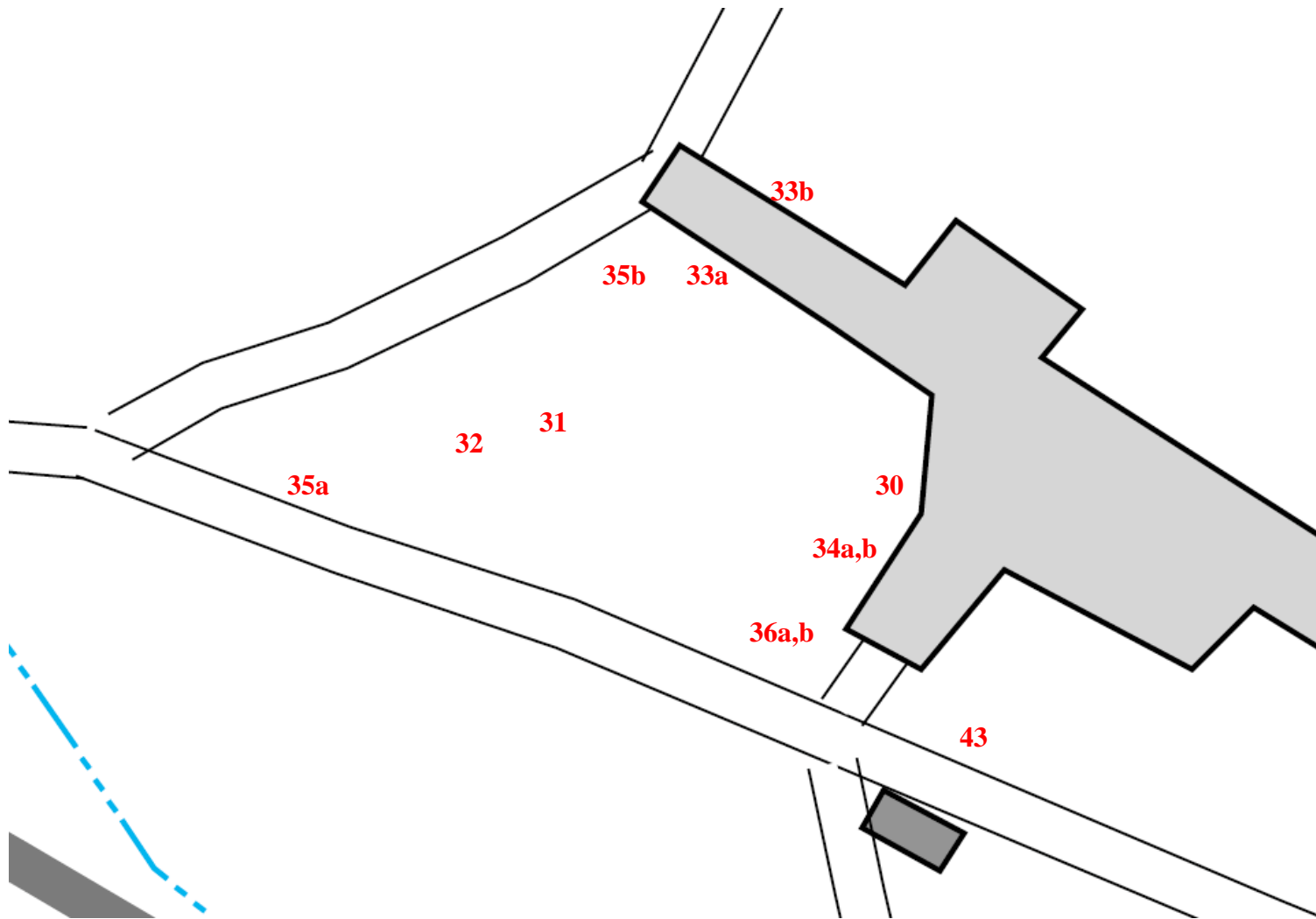

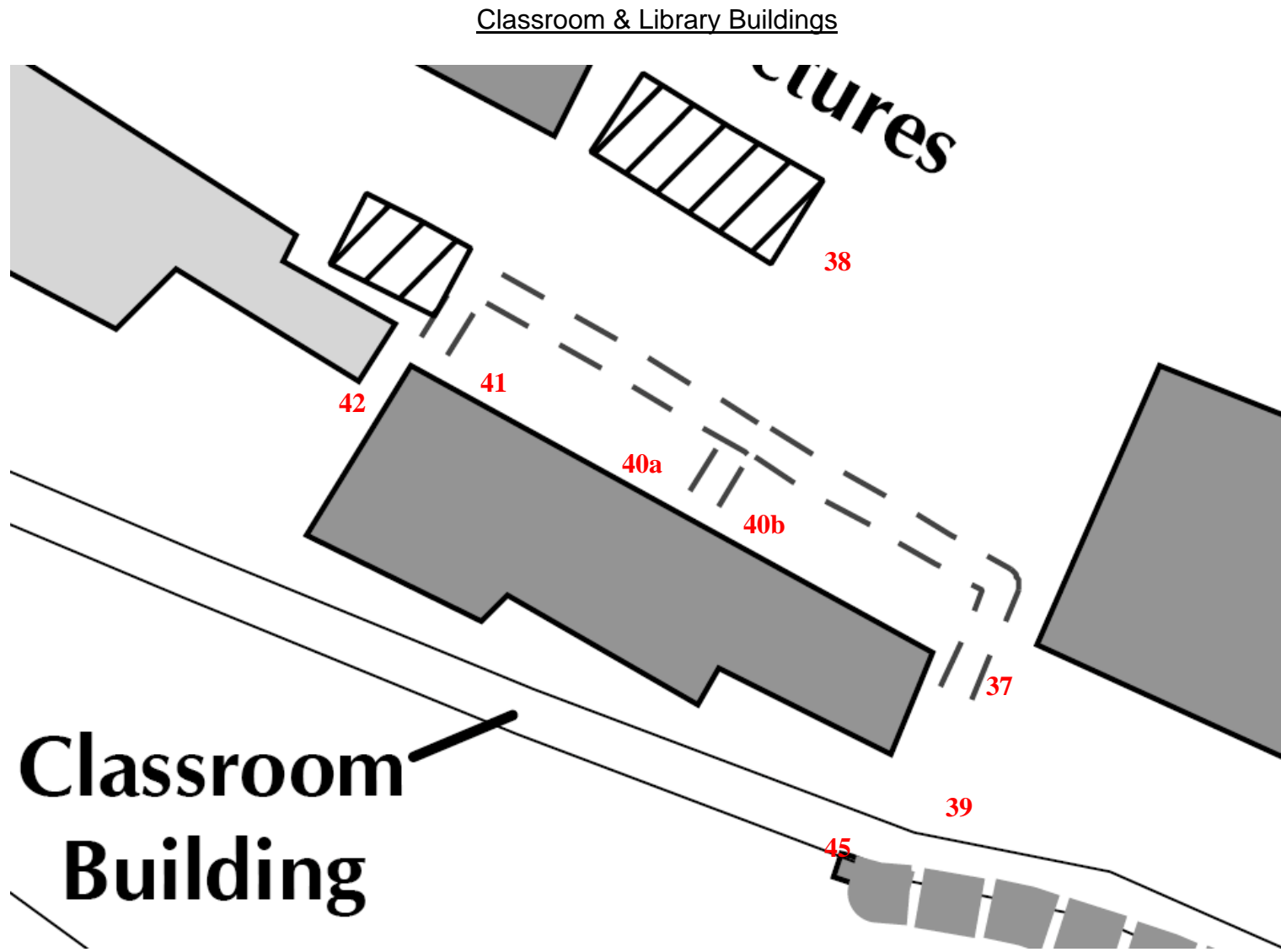

Classroom & Library Buildings

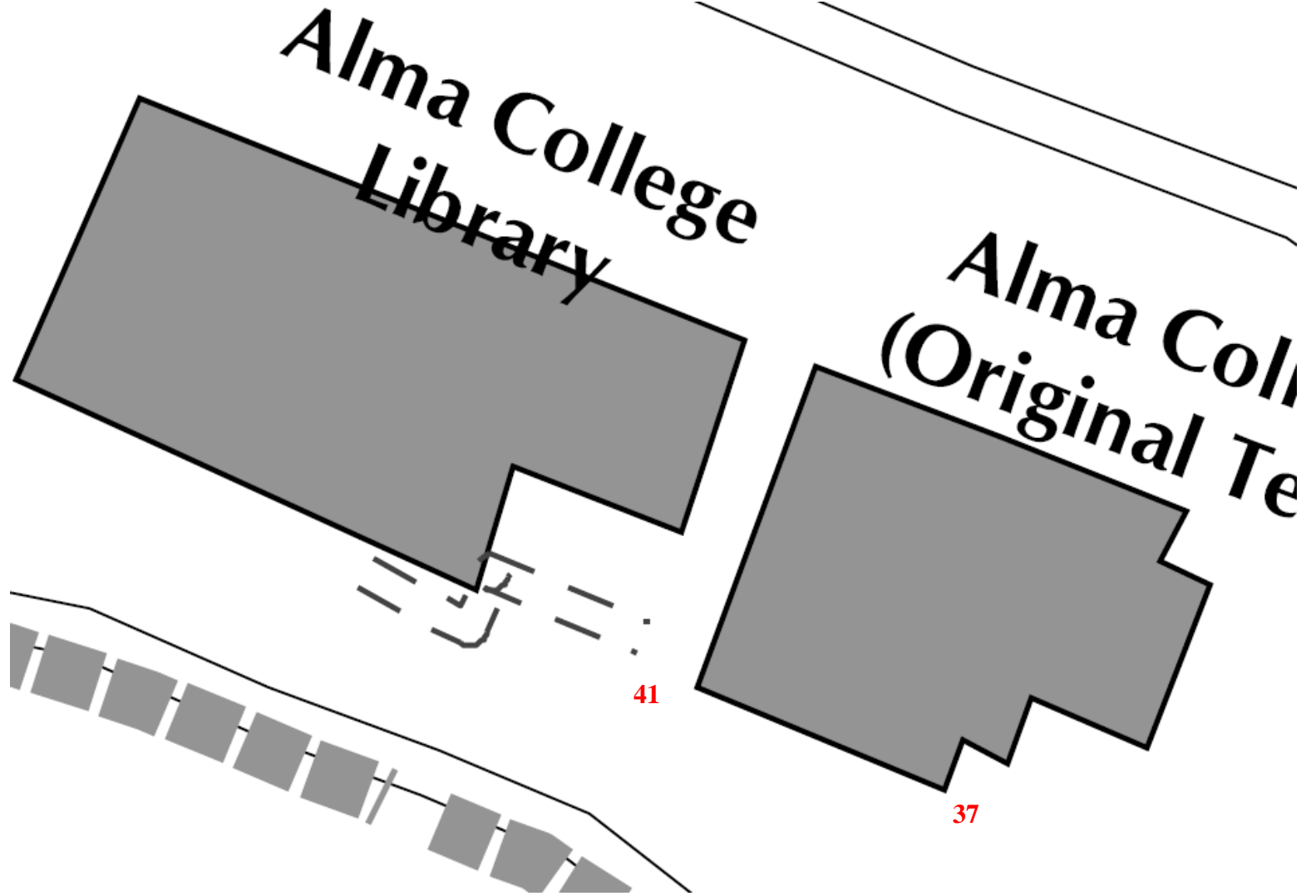

Classroom & Library Buildings / Marian Shrine

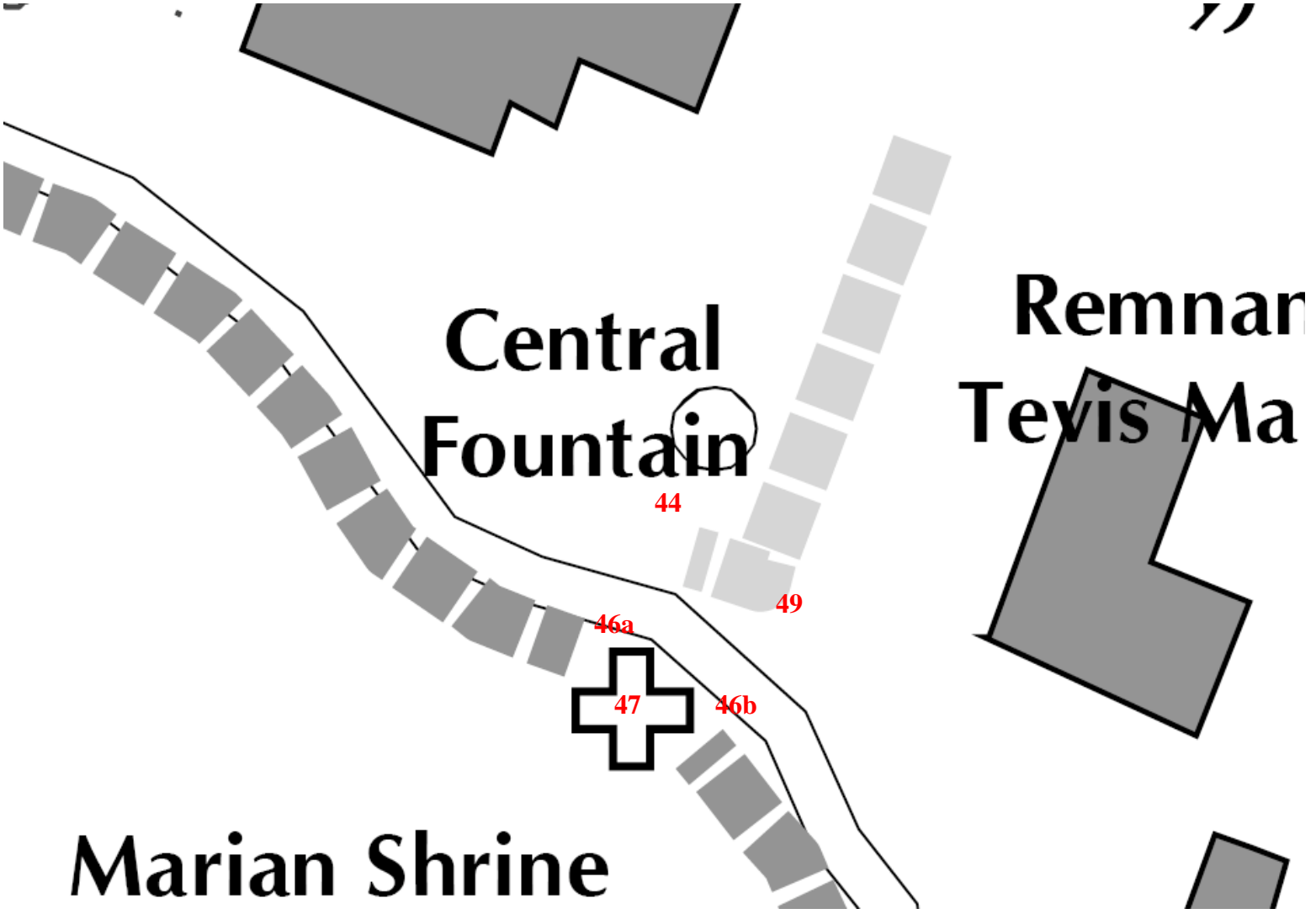

**Marian Shrine**



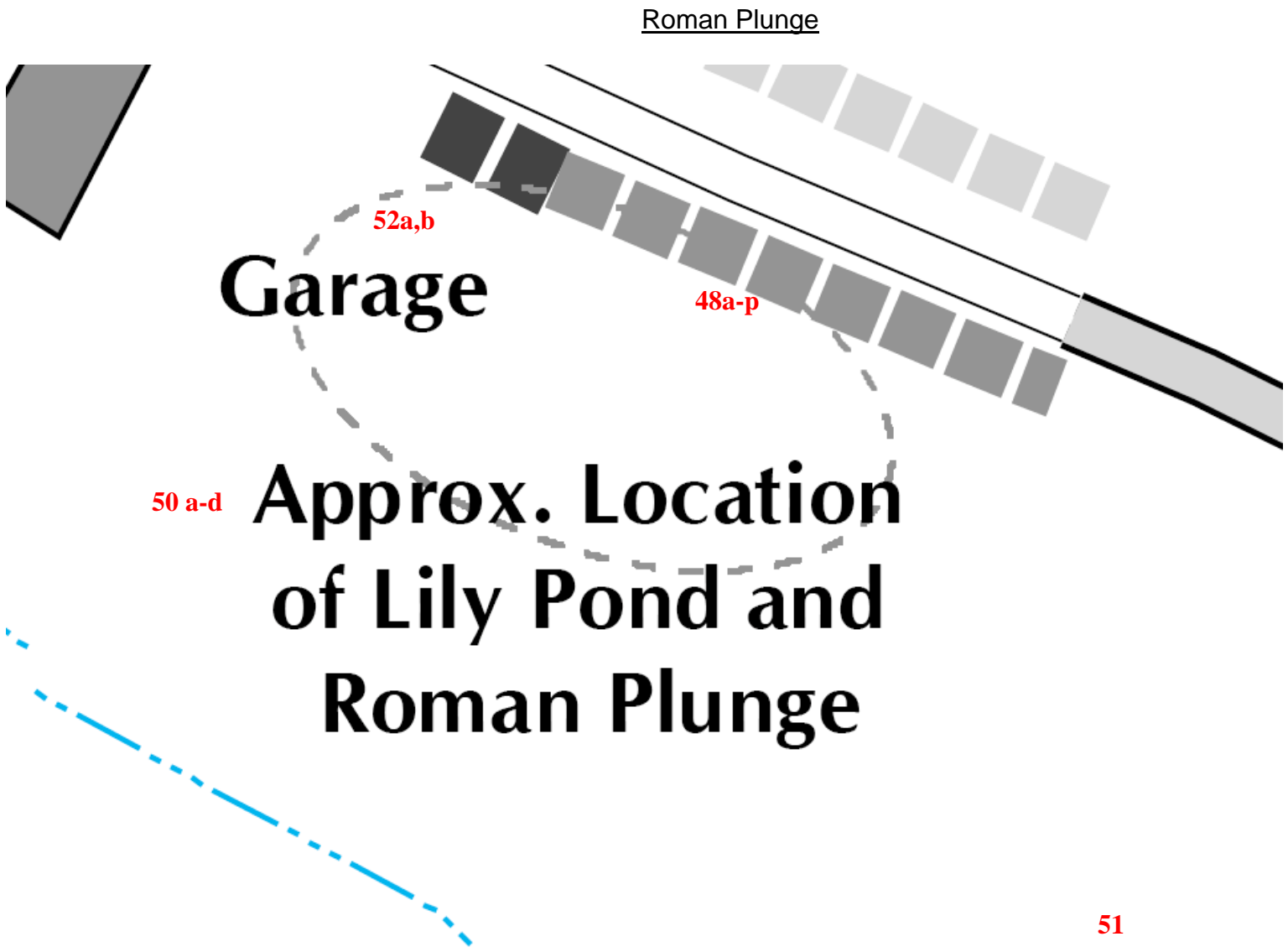

**Garage**

Roman Plunge

**Approx. Location  
of Lily Pond and  
Roman Plunge**

52a,b

48a-p

50 a-d

51

Blue Atlas Cedar Grove

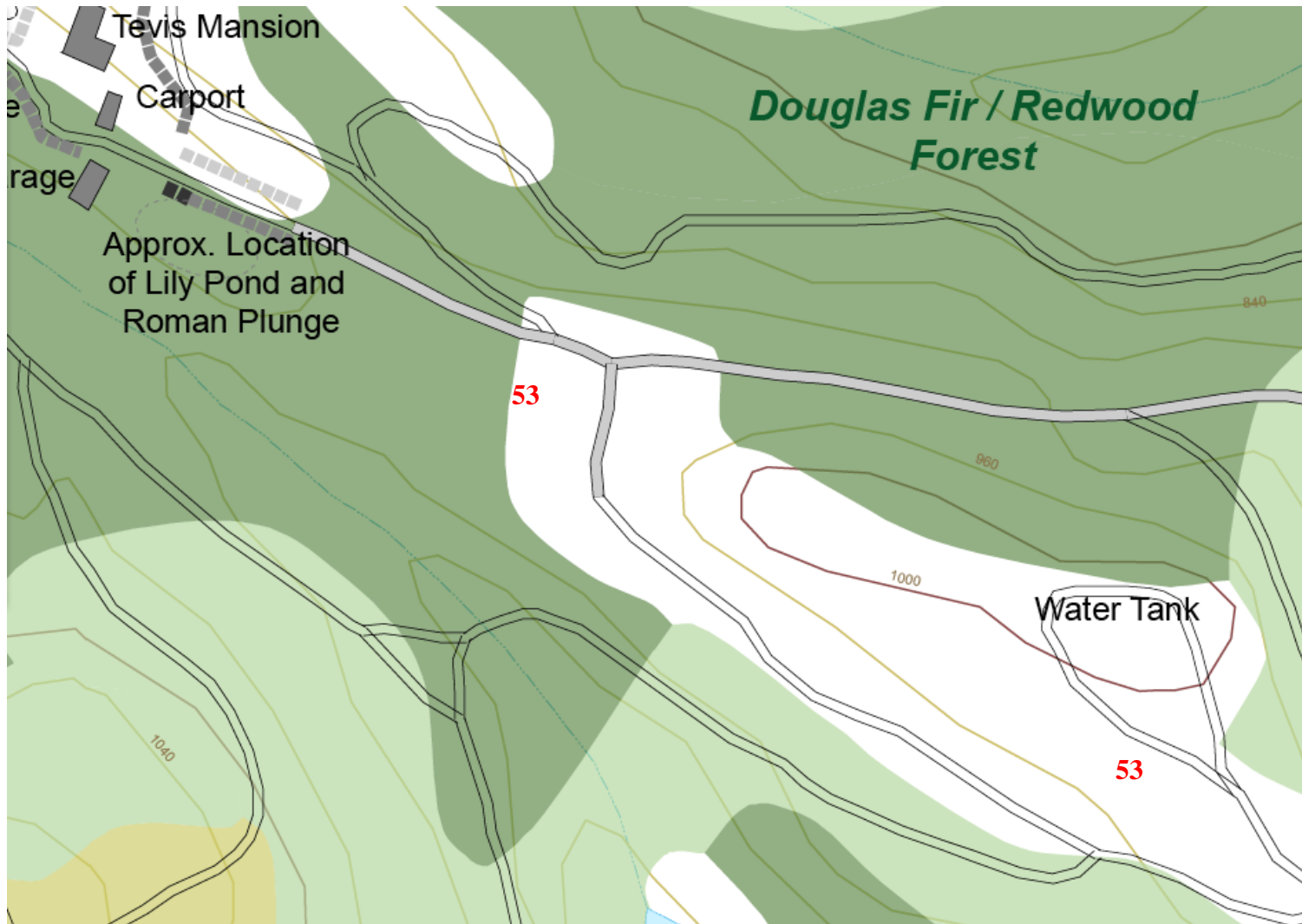

## Road Below House

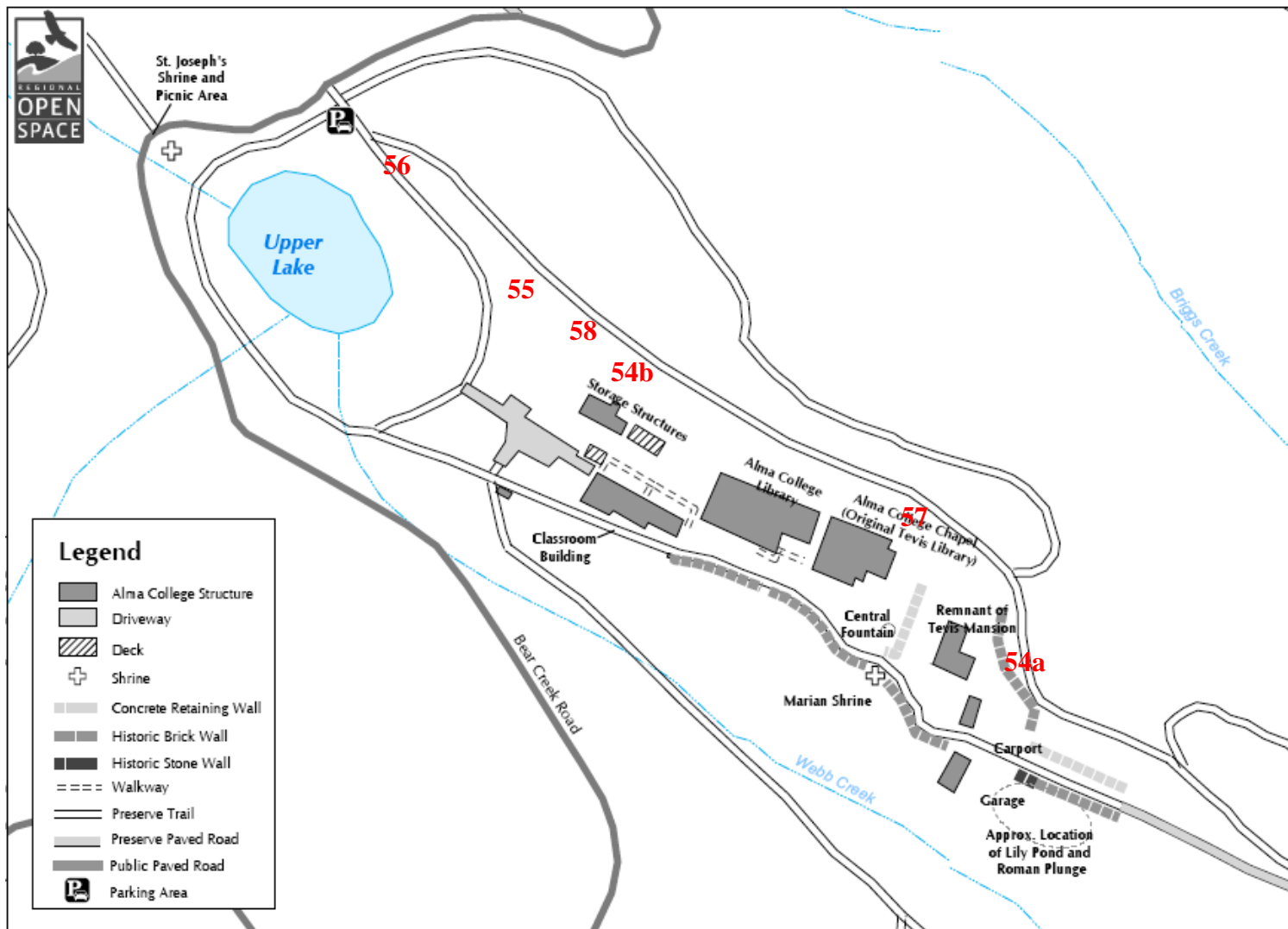

**II. ASSESSMENTS & ANALYSES**  
**SECTION F - CULTURAL LANDSCAPE ANALYSIS**

- Exhibit F-1. Alma College Fire Insurance Map
- Exhibit F-2. Summary of Previous Site Assessments
- Exhibit F-3. Alma College Site History
- Exhibit F-4. Alma College Cultural Landscape Contributing Elements





---

## II. ASSESSMENTS & ANALYSES

### SECTION F - CULTURAL LANDSCAPE ANALYSIS

---

#### History and Development of the Alma College Site

(See Exhibit F-1: Alma College Fire Insurance Map and Exhibit F-3: Alma College Site History)

The current site is most closely associated with Alma College but even before the Jesuits, the site had a rich history that paralleled the general patterns in the local area and California history. In the 1850s, Webb's mill was developed on the site for logging and milling of the area's madrone and redwood trees.<sup>7</sup> Within the same decade, James Howe acquired the property and dammed Webb's Creek to create a water body, now known as Upper Lake, to pressure-drive the site's saw-mill. After the 1860s, the town of Alma developed within the vicinity of the subject site with a small train depot in 1881.<sup>8</sup> From 1887, the site became a rural estate for several wealthy persons, Captain Stillman H. Knowles (1887-1894), John F. Farley (1894), James L. and Maria Rosina Flood (1894-1905), and Dr. Henry Tevis (1905-1934).

Dr. Tevis acquired the property, in 1905, with the improvements constructed by the Floods, including the large retaining walls creating the flat ridge, a main estate house, and numerous secondary buildings.<sup>9</sup> The early buildings were damaged in the 1906 Earthquake and were eventually demolished as Dr. Tevis developed the site anew. Dr. Tevis developed a large residence fronted by a garden fountain connected by a walkway to a library, two adjacent water features, the Lily Pond and Roman Plunge, and a small village east of the site with barns and servants' quarters for support of his property.<sup>10</sup> Tevis was also known for his of gardening and cultivated many introduced species on his estate, especially junipers and evergreens.<sup>11</sup> Tevis developed a stable complex north of the main site and various other features, including a bridge, outside the boundaries of this study.

After the era of Dr. Tevis, the California Province of the Society of Jesus acquired and occupied the Alma College property from 1934 and used it as a theological seminary until 1969. The early Alma College campus was organized and constructed between 1934 to 1937. The Tevis house, library, and Lily Pond and Roman Plunge landscape features were used and altered by the Jesuits. The Tevis Library was converted to the Alma College chapel building and the Tevis house into a faculty residence. In addition, Alma College built several buildings including a library, classroom building, dormitories and a garage/residence. In 1950, the western end of the 1934 library was truncated and a large library addition was constructed. The Jesuits developed a formal landscape

---

<sup>7</sup> Young, John V. *Ghost Towns of the Santa Cruz Mountains*. Lafayette, CA: Great West Books, 1984, p. 98, as cited in Page & Turnbull, Inc. *Alma College Historic Resource Study, Bear Creek Road, Los Gatos, California*. San Francisco, California, Revised Draft, November 2005, p. 4.

<sup>8</sup> San Jose Mercury 1895: 152 as cited in Page & Turnbull, Inc. *Alma College Historic Resource Study, Bear Creek Road, Los Gatos, California*. San Francisco, California, Revised Draft, November 2005, p. 5.

<sup>9</sup> Page & Turnbull, Inc. *Alma College Historic Resource Study, Bear Creek Road, Los Gatos, California*. San Francisco, California, Revised Draft, November 2005, p. 6.

<sup>10</sup> *Ibid*, pp. 10-11.

<sup>11</sup> Blake, Philip C., S.J. "Alma Through the Years: A Pictorial History of the 'Alma Dale' Estate." *Eden, Journal of the California Garden & Landscape History Society*, Fall 2006, p. 6.

around Upper Lake and through their long narrow campus. The built features of the landscape included the Marian and St. Joseph Shrines constructed between 1949 and 1951. From 1969 to 1994, the site was leased by the Jesuits to other occupants who used it as a school. Subsequent ownership passed to Hong Kong Metro Realty in 1989, which hoped to develop a country club and golf course. An environmental impact report was prepared for the golf course, but the project was not developed. Ownership passed to Midpeninsula Regional Open Space District in 1999 after some intermediate ownership by various parties.

In late 1970, the Tevis house burned down with only portions remaining including a structure referred to as the carport. At the end of the Alma College period, for risk management purposes, the dormitories were demolished along with the Alma Village complex, which was built to support the Tevis estate and, later, Alma College. In addition, the Lily Pond and Plunge were removed or infilled.

### **Previous Site Assessments**

(See Exhibit F-2: Summary of Previous Site Assessments)

Previous studies have evaluated the Alma College site to varying degrees. The earliest study was performed in 1995 as part of the *Los Gatos Country Club Environmental Impact Report*. "Appendix G: Historical and Architectural Evaluation," by Archives & Architecture, provided a description of the major structures on the Alma College site but did not describe the related landscape and its features that contribute to the site's overall character.

In 1995, Santa Clara County listed the Alma College complex in its local inventory as a historic resource. In 2004, the county began a process of formalizing its list of properties by preparing Department of Parks and Recreation (DPR) historic resource 523 forms, issued by the state Office of Historic Preservation. The 2004 DPR forms, prepared by Archives & Architecture, describe that the Alma College Complex, identified also as the Flood / Tevis estate, as being composed of two parcels including the main campus and other structures outside the scope of this report. The forms describe a brief history of the main campus site, the major buildings and also other structures not noted as part of the site in the previous study. Although the DPR forms have not been formally adopted, the county regards the site as a historic resource, eligible to the California Register.

In 2005, another assessment, *Historic Resource Study: Alma College, Los Gatos, California (Revised Draft)* was prepared by Page & Turnbull, Inc. The study, in addition to providing a history of the site and its major buildings, noted various landscape features previously omitted. The study did not define the significance of these features or describe in detail the plantings of the landscape which were integrally tied with the site.

The three studies, combined, did give a sense of the site's layered history from the early milling period, to the rural estates of the wealthy including the Floods and Henry Tevis, and the site redevelopment as a seminary for the Province of the Society of Jesus, referred to as the Alma College period. The studies noted a period of significance of 1934 to 1969 for the Alma College site. The 1995 study and DPR forms found that the site had potential to be nominated as a historic district under National Register Criterion A. Due to its loss of integrity, the 2005 study noted that the site was ineligible as a historic district under California Register Criterion 1 (comparable to National Register Criterion A) but suggested that, with the preparation of a cultural landscape report, the

Alma College site may qualify as cultural landscape under “historic designed landscape” or “historic vernacular landscape.” It should be clarified that cultural landscapes are evaluated as districts under the California Register. The 2005 study was not clear on this point and was also limited in its scope in reviewing the site’s vegetation and landscape features along with buildings to form a cultural landscape.

In regard to the Chapel building, the 1995 study implied that it was individually significant under Criterion 1 for association with Alma College and Criterion 2 for association with Dr. Tevis.<sup>12</sup> The DPR form evaluation found the Chapel individually significant under Criteria 1, 2 and 3 for its association with the era of estates, Dr. Tevis and for the work of a master architect. The 2005 historic resource study found that the associations under Criteria 1 and 2 were not significant but the Chapel could be considered for its design under Criterion 3 of the California Register.<sup>13</sup>

### **California Register of Historic Resources Criteria for Evaluation of Significance**

A property, evaluated for eligibility to the California Register of Historic Resources, may be defined as a site, building, structure – such as a bridge or dam – object, or district – including cultural landscapes. A cultural landscape is defined by the National Park Service as:

“A geographic area, including both cultural and natural resources and the wildlife or domestic animals therein, associated with a historic event, activity, or person, or that exhibit other cultural or aesthetic values. There are 4 general types of cultural landscapes, not mutually exclusive: Historic sites, historic designed landscapes, historic vernacular landscapes and ethnographic landscapes.”<sup>14</sup>

Under the California Register, “A district possesses a significant concentration, linkage, or continuity of sites, buildings, structures, or objects united historically or aesthetically by plan or physical development...When conducting a comprehensive survey you should generally record large and complex cultural landscapes as districts.”<sup>15</sup> This definition describes the Alma College site, therefore, the site is evaluated as a cultural landscape eligible under the California Register as a district.

This study evaluates the potential eligibility of the Chapel, as an individual building, and the overall Alma College site, as a historic district to the California Register. Evaluation begins with determination of a property’s significance based on the four California Register Criteria. If one or more of the following criteria describe the significance of the property and the property retains historical integrity, the resources are eligible to the California Register:

<sup>12</sup> Laffey, Glory Anne and Detlefs, Robert G. *Historical and Architectural Evaluation for the Los Gatos Country Club in the County of Santa Clara*. San Jose, California: Archives & Architecture, 24 February 1995. Published in the *Los Gatos Country Club Environmental Impact Report*, Appendix G, p. 14.

<sup>13</sup> Page & Turnbull, Inc. *Alma College Historic Resource Study, Bear Creek Road, Los Gatos, California*. San Francisco, California, Revised Draft, November 2005, p. 32.

<sup>14</sup> Page, Robert R.; Gilbert, Cathy A.; and Susan A. Dolan. *Guide to Cultural Landscape Reports: Contents, Process, and Techniques*. Washington DC: United States Department of the Interior, National Park Service, Park Historic Structures and Cultural Landscapes Program, 1998, p.12.

<sup>15</sup> Office of Historic Preservation. *Instructions for Recording Historical Resources*. Sacramento, California, March 1995, pp. 2-3.



Criterion 1.

*“Associated with events that have made a significant contribution to the broad patterns of local or regional history or the cultural heritage of California or the United States.”*

Criterion 2.

*“Associated with the lives of persons important to local, California or national history.”*

Criterion 3.

*“Embodies the distinctive characteristics of a type, period, region or method of construction or represents the work of a master or possesses high artistic values.”*

Criterion 4.

*“Has yielded, or has the potential to yield, information important to the prehistory or history of the local area, California or the nation.”*

### **Evaluation of the Chapel for Individual Eligibility**

This report concurs with the 2005 study in that the Chapel’s associations, under Criteria 1 and 2, are not significant, but also finds that the Chapel is not individually eligible for its design or as the work of a master under Criterion 3.

The Chapel was built for Dr. Tevis as his library in 1909. As shown in a historic photograph, the building originally had a veranda and wood railing on at least the south and east sides (See Image 1, Exhibit D-2). During the Alma College period, the veranda and railings on these sides were removed. At the north, a veranda with railing, assumed to be original, currently exists. The fireplace on the interior and its exterior chimney were also removed. The Jesuits changed the building’s use and added two side chapels each on the north and south sides. The building was changed and it no longer conveyed the original design intent or use. The building still retains some characteristics of the original design but not in its entirety. Although it may have been significant for its original design under Criterion 3, due to alterations this is no longer applicable.

Previous studies implied that the library built by Tevis was the work of a master, attributed to either the firm of Trowbridge & Livingston or Julia Morgan but neither claim has primary documentation. These architects were associated with other buildings on the site. Original drawings for the Tevis House were associated with Trowbridge and Livingston of San Francisco.<sup>16</sup> A listing of Julia Morgan works includes the “Tevis house and barns” at Alma but not the Tevis Library.<sup>17</sup> Notations and related archival photographs imply that the Tevis Barn in Alma Village was designed by Julia Morgan.<sup>18</sup> Since these architects are not associated with the Tevis Library, the building cannot be documented as the work of a master. Even if the building were the work of another master, the alterations in the design would have diminished its integrity.

Therefore, the Chapel (Tevis Library) is not individually eligible to the California Register under Criteria 3 but does contribute to the overall site significance.

---

<sup>16</sup> California Jesuit Archives, Santa Clara. Alma College File.

<sup>17</sup> Boutelle, Sara Holmes. *Julia Morgan Architect*. New York: Cross River Press, 1988, p. 250.

<sup>18</sup> California Jesuit Archives, Santa Clara. Alma College File.

## **Evaluation of Alma College as a Cultural Landscape**

(See Exhibit F-4: Alma College Cultural Landscape Contributing Elements)

The 1995 study and 2004 DPR forms considered the Alma College site eligible to the California Register as a historic district under Criterion 1 but, due to loss of integrity, the 2005 study noted that it appears ineligible. The analysis, under this report, considers the Alma College site eligible to the California Register as a cultural landscape, a type of historic district, based on a more comprehensive evaluation of vegetation and landscape features in addition to structures. The following describes the site's significance.

### Overall Site Development

The significance of the Alma College site, under Criterion 1, is that it reflects the broad patterns of local and California history in its layers comprised of different periods and uses. Although the site features that remain are most closely identified with the Alma College period, the previous historic layers are integral to how Alma College developed. Each layer was built on previous layers and remnants of earlier periods remain as evidence of the site's layered history.

### Milling Period (1850s)

The current site acknowledges its milling past with Upper Lake established in the 1850s.

### Tevis Period (1906-1934)

The era of wealthy estates is evidenced by the site walls, the Tevis Library, and ruins of the Tevis House.

### Early Alma College Period (1934-1949)

The Alma College period marks the site's most recent institutional period beginning in 1934 and ending in 1969 with other institutional uses afterward. During the Alma College period, the Tevis House was converted to the Faculty Residence and the Tevis Library to the Alma College Chapel. The Faculty Residence acted as a terminus to the spinal axis of the site and destruction of the building by fire had a marked effect on the enclosure and readability of the site. Only two carport structures remain as remnants of the Faculty Residence. Carport A with its lower terrace was part of the main building complex. In a historic photograph, the area of Carport B is not covered but the roof may have been constructed sometime afterward (See Image 59, Exhibit D-2). Both carports contribute to the cultural landscape and have interpretive value.

The Jesuits built the Library (1934), Classroom (1935) and Dormitories (1934-1937). The 1934 Library was built as an integral part of the original campus plan and had a close relationship with the Alma College Chapel and Faculty Residence. The Classroom building and Dormitories, placed opposite to each other, created an enclosed space accentuating the long spine of the site. The articulation of these three buildings and the Faculty Residence was cohesive with gable roofs, dormers, shingles, wood stick work and use of brick. The Classroom remains intact and maintains the southern edge of the lower campus. Although the Dormitories were demolished leaving only foundations and an obvious void, the ruin still has interpretive value.

The Garage/Residence, assumed to be built in the 1940s, contributes to the cultural landscape but, as a utilitarian building, it is not integral to understanding the site as a whole.

The Wood Shed that exists to the southwest of the Classroom building has no known date of construction. Its articulation is reminiscent of the early Alma College period with decorative wood shingles, gable roof and wooden barn doors. Although its history cannot be established, the shed has aesthetic value.

#### Later Alma College Period (1950-1969)

In 1950, the large Library Addition was built to the west of the 1934 building. The addition completed the north edge of the campus but also changed the hierarchy of the site's buildings, the view sight lines, and spatial qualities of the early campus. The 1950 Library structure became the new focal point of the main axis of the campus as viewed from Upper Lake, partially obscuring the Faculty Residence beyond. As the most dominant architectural feature, the addition's size and detailing have little relationship to the aesthetic of the early Alma College campus. Even so, the 1950 Library does have a contributing role within the cultural landscape as part of its development and as an enclosing element.

The Marian and St. Joseph Shrines were constructed between 1949 and 1951. Along with the other landscape elements, these features are important to the interpretation of the site and its recent history and use and provide points of orientation within the cultural landscape. (For other character-defining landscape features, see Exhibit E-4, Landscape Features - Survey of Features)

#### Significance and Period of the Alma College Cultural Landscape

The significance of the Alma College site is based on the depth of its layered history paralleling that of California and local history under Criterion 1 of the California Register. This study defines the period of significance, established by the extant structures and features of the site, as circa 1850 to 1951, beginning with the establishment of Upper Lake and ending with the placement of the Jesuit shrines. The significance and period of significance are the basis of the evaluation of integrity.

#### **The California Register of Historic Resources Aspects of Integrity**

After assessment under the California Register Criteria to determine significance, a property is assessed under the seven aspects of integrity listed below. Integrity can be defined as the extent to which a property conveys its significance and time period rather than the extent of physical deterioration as determined through a conditions survey. For an evaluation of integrity, one can ask, "does the property express its historical significance via each aspect of integrity?" Usually, the answer is "yes" or "no."

##### Integrity Aspect 1. Location

*Integrity of location refers to whether a property remains where it was originally constructed or was relocated.*

*Integrity Aspect 2. Design*

*Integrity of design refers to whether a property has maintained its original configuration of elements and style that characterize its plan, massing, and structure. Changes made after original construction can acquire significance in their own right.*

*Integrity Aspect 3. Setting*

*Integrity of setting refers to the physical environment surrounding a property that informs the characterization of the place.*

*Integrity Aspect 4. Materials*

*Integrity of materials refers to the physical components of a property, their arrangement or pattern, and their authentic expression of a particular time period.*

*Integrity Aspect 5. Workmanship*

*Integrity of workmanship refers to whether the physical elements of a structure express the original craftsmanship, technology and aesthetic principles of a particular people, place or culture at a particular time period.*

*Integrity Aspect 6. Feeling*

*Integrity of feeling refers to the property's ability to convey the historical sense of a particular time period.*

*Integrity Aspect 7. Association*

*Integrity of association refers to the property's significance defined by a connection to a particular important event, person or design.*

**Evaluation of the Alma College Cultural Landscape under the Aspects of Integrity**

Since the most recent occupation of the site – and its strongest physical connection to California history – was by the Jesuits, the evaluation of integrity begins with the buildings and features that were constructed during the Alma College period including the 1934 and 1950 Library structures, Classroom building, Dormitories and the Marian and St. Joseph Shrines. The overall integrity of the site is also tied to the elements that express the other layers of site history including Upper Lake, the site retaining walls, the ruins of the Tevis House and its central fountain, the Tevis Library / Alma College Chapel, the Tevis Lily Pond and Roman Plunge.

The Alma College site retains integrity of location, design, setting, materials, workmanship, feeling and association. The extant buildings and ruins of demolished buildings are in the same location as when they were first constructed. Although only portions of the design, materials and workmanship exist to convey the site's significance, the remnants are integral to the cultural landscape and have interpretive value. The site still has a rural setting although the formal landscaping has been lost due to lack of water, maintenance and/or overgrowth of native species. The site still conveys a historical feeling but it has been compromised with vegetation overgrowth and disrepair of structures.

The cultural landscape has endured the loss of several buildings, the plague of overgrown vegetation, and has been altered by the vicissitudes of time. The destruction by fire of the Faculty Residence (Tevis House) and demolition of the dormitories left voids in the intended design and changed the relationship of the buildings within their



setting. So, one might ask, “Do ruins have integrity?” In terms of addressing the features and integrity of the Alma College cultural landscape, it is not necessary for the property to retain all its historic physical features or characteristics to convey its past. It must retain, however, the essential physical features that enable it to convey its historic identity. The essential physical features are those features that define both *why* this is a significant property and *when* it was significant. For integrity of association, ruins can still convey a sense of history when accompanied by interpretive material. In the case of the Tevis House / Faculty Residence, the building has archival documentation, both drawings and photographs that can provide a concept of the building’s physical presence and convey a sense of the site’s history. These ruins may need stabilization or partial reconstruction. The site’s intact structures and landscape, including its ruins, are an integral part of its character and solidify its integrity of association.

### **Summary of the Alma College Cultural Landscape Significance and Integrity**

Overall, the Alma College site is significant under Criterion 1 and retains integrity under the seven aspects. The site is considered a cultural landscape, which is a type of district as defined by the California Register. The site reflects the pattern of settlement that parallels local and California history. Similar to a palimpsest, the Alma College site evidences several layers of development with portions imperfectly erased leaving a trail of interpretive value.

It is recommended that, in Phase II, a landscape historian perform additional research into the landscape’s history to solidify the site’s historical significance and integrity for a California Register nomination as a cultural landscape, under the larger umbrella of historic district. Research would include the verification of the background, date, and design intent of the cultural landscape and its features including their overall relationship to the broad patterns of local and California history in reference to the layering of periods composed of milling / lumbering, the estate period and Jesuit period. This last period, well reflected by the extant features on the site, is a particularly valuable topic of focus because of the importance of Alma College as the first Jesuit seminary on the West Coast. The landscape historian would complete the standard 523 Forms, required for formal documentation of historic resources, and submit them to Santa Clara County to augment their files for this county resource and to the California Office of Historic Preservation in Sacramento for acceptance as a historic district.

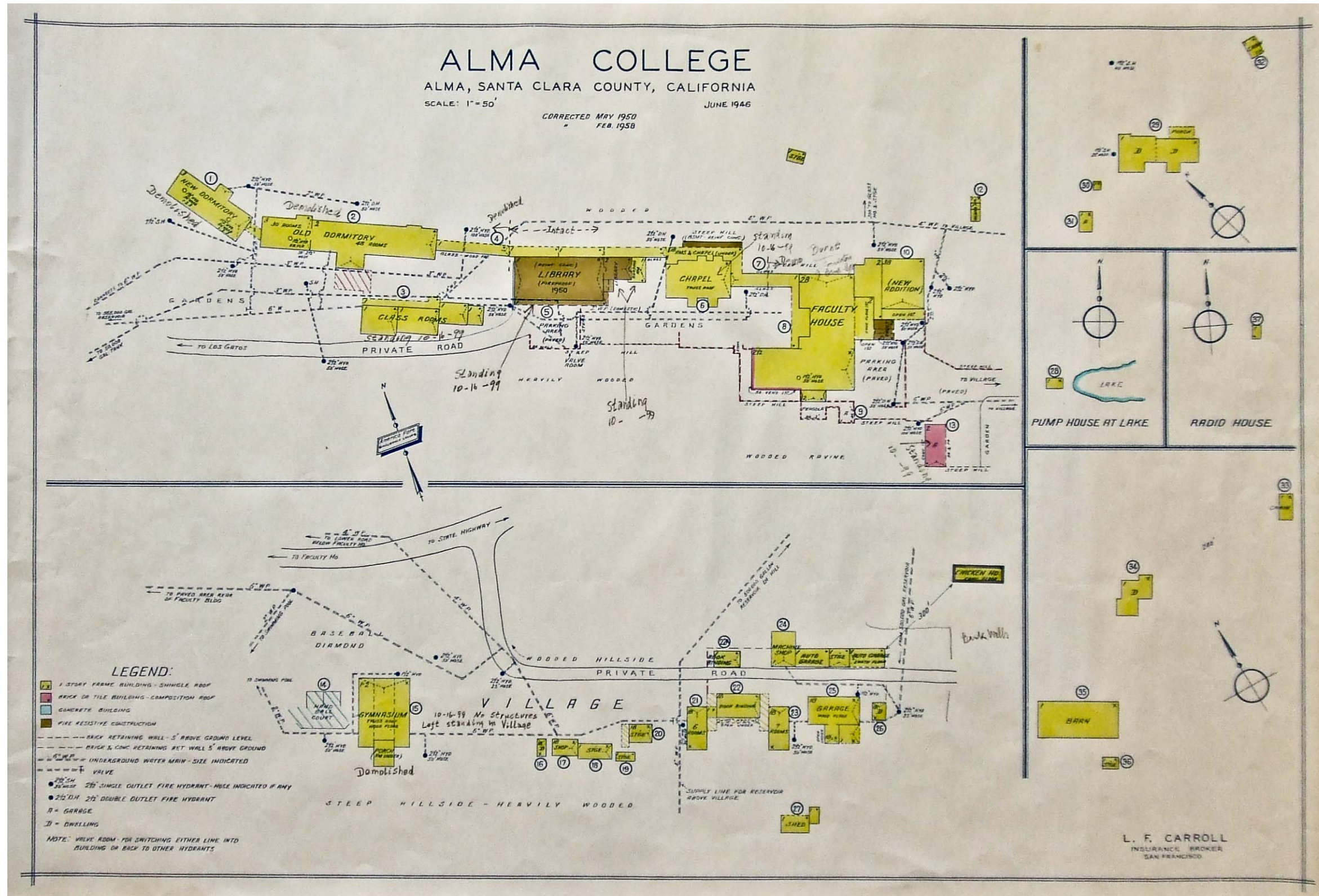

Alma College Fire Insurance Map. The map is dated last in 1958 but subsequent hand notations of condition were made in 1999. (L.F. Carroll, Insurance Broker. *Alma College, Alma, Santa Clara County, California (Map)*, 1958. California Jesuit Archives, Santa Clara. Alma College File.)





This chart summarizes previous evaluations of the Alma College site. The chart lists the elements of the site, whether these are mentioned in each of the studies, the important characteristics highlighted, and the significance and integrity of the element.

The Alma College Complex was added to the Santa Clara County Heritage Resource Inventory in 1995 and is considered a county resource.

Element	Los Gatos Country Club EIR, Appendix G: Historical & Architectural Evaluation (Archives & Architecture, February 24, 1995)				Department of Parks and Recreation 523 Forms (Archives & Architecture, June 10, 2004)				Historic Resource Study: Alma College, Los Gatos, CA (Page & Turnbull, November 2005)			
	Mention	Description & Characteristics Cited	Significance	Integrity	Mention	Description & Features Cited	Significance	Integrity	Mention	Description & Features Cited	Significance	Integrity
Site (1850s to the present)	Yes	Various features described. Contributing extant features - Chapel, Classroom, 1934 & 1950 Library, Upper Lake, brick alcove / picnic area (St. Joseph shrine)	NR Criterion A - Potential Alma College historic district Period of Significance: 1934-1969	Yes Retains setting & remaining structures maintain internal coherence	Yes	Various features described. Contributing extant features - Chapel, Classroom, 1934 & 1950 Library, Upper Lake, brick alcove / picnic area (St. Joseph shrine)	NR Criterion A & CR Criterion 1 - Potential Alma College historic district Period of Significance: 1934-1969	Yes Retains setting & remaining structures maintain internal coherence	Yes	Various features described. Contributing extant features - Chapel, Classroom, 1934 & 1950 Library, Upper Lake, St. Joseph shrine	CR Criterion 1 - Significant under but not eligible as a Alma College historic district for lack of integrity. Period of Significance: 1934-1969 Suggests preparation of cultural landscape report for potential as "historic designed landscape" or "historic vernacular landscape"	No All aspects except workmanship have been lost
Chapel (1909/1934)	Yes	Swiss Chalet/Craftsmen style Gabled roof with wide overhanging eaves Gabled wings used as side chapels Gable end with stick work, brackets & decorative fascia boards Shingle exterior Clinker brick foundation Tall multi-pane French windows/doors Entrances at north veranda and east walkway Clay tile veranda with open wood railing Interior wood beam ceiling	See Site Significance Most individually significance of all buildings for association with Tevis and chapel use for Alma College; does not discuss a separate listing under NR Criteria	See Site Integrity	Yes	Swiss Chalet/Craftsmen style Gabled roof with wide overhanging eaves Gabled wings used as side chapels Gable end with stick work, brackets & decorative fascia boards Shingle exterior Clinker brick foundation Tall multi-pane French windows/doors Entrances at north veranda and east walkway Clay tile veranda with open wood railing Interior wood beam ceiling Tevis fireplace removed in Alma College period Altar installed by Alma College Basement rooms used as sacristy	See Site Significance NR Criteria A, B, C CR Criteria 1, 2, 3 Individually significant for association with Dr. Tevis and work of a master - Julia Morgan	See Site Integrity. Individual integrity not discussed.	Yes	One-story building, square in plan Gable roof with half-timbering at gable end Pent roof overhangs Brick foundations Wide porch with low wood guardrail East walkway to Tevis mansion French doors Dark wood floors (covered by carpet) Paneled walls Exposed wood truss ceiling Tevis library was converted to Chapel Side chapels added Altar added Tevis chimney and fireplace removed	See Site Significance CR Criterion 3 Individually eligible as an example of Craftsman architecture and aesthetic	See Site Integrity Individual Integrity -Yes for all aspects except setting and design
Library (1934)	Yes	Gabled roof with dormers Overhanging eaves with exposed rafters Gable end with decorative stick work, brackets, heavy redwood beams Shingles at upper building Brick at lower building Multi-pane casement windows Gabled porch entryway	See Site Significance	See Site Integrity	Yes	Gabled roof with dormers Overhanging eaves with exposed rafters Gable end with decorative stick work, brackets, heavy redwood beams Shingles at upper building Brick at lower building Multi-pane casement windows Gabled porch entryway	See Site Significance	See Site Integrity	Yes	Roof with exposed eaves dormers Shingles at upper building Brick at lower building Paired ten-pane casement windows Semi-enclosed vestibule with a spindle screen window North covered walkway added later One-story shingled additions at east & west Interior wood paneled walls at entry Wood floor	See Site Significance	See Site Integrity
Library (1950)	Yes	Stucco siding Low pitched gable roof with clay-tiles Wide overhanging eaves Casement windows under eaves Full height fixed pane windows at east side Large auditorium on upper floor Classrooms/office on lower floor First floor accessed via the north walkway	See Site Significance	See Site Integrity	Yes	Stucco siding Low pitched gable roof with clay-tiles Wide overhanging eaves Casement windows under eaves Full height fixed pane windows at east side Large auditorium on upper floor Classrooms/office on lower floor First floor accessed via the north walkway	See Site Significance	See Site Integrity	Yes	Stucco-finished reinforced concrete Gabled clay-tiled roof West façade: Double-height window South façade: low colonnade at first story, flat walkway at second, concrete Jesuit seal at West end East façade: Planter and stairs, main entry door & windows with flat stucco trim North façade: Covered walkway, facade adjoins old library	See Site Significance	See Site Integrity



Element	Los Gatos Country Club EIR, Appendix G: Historical & Architectural Evaluation (Archives & Architecture, February 24, 1995)				Department of Parks and Recreation 523 Forms (Archives & Architecture, June 10, 2004)				Historic Resource Study: Alma College, Los Gatos, CA (Page & Turnbull, November 2005)			
	Mention	Description & Characteristics Cited	Significance	Integrity	Mention	Description & Features Cited	Significance	Integrity	Mention	Description & Features Cited	Significance	Integrity
Classroom Building (1934)	Yes	Swiss chalet style Gabled roof with exposed rafter ends Gable ends with stick work Shingle siding East side, horizontal wood wainscot Six-over-one double-hung windows Covered walkway Clerestory window above walkway Glazed multi-pane doors at classrooms Gabled porch entrances with exposed joists & decorative fascia boards Open-beamed ceiling in classrooms	See Site Significance	See Site Integrity	Yes	Swiss chalet style Gabled roof with exposed rafter ends Gable ends with stick work Shingle siding East side, horizontal wood wainscot Six-over-one double-hung windows Covered walkway Clerestory window above walkway Glazed multi-pane doors at classrooms Gabled porch entrances with exposed joists & decorative fascia boards Open-beamed ceiling in classrooms	See Site Significance	See Site Integrity	Yes	One-story, long narrow building with two sections Brick foundation Exterior arcade along north side of building Brick vestibule with spindle screen openings Wood-framed walls Shingle siding Asphalt shingle gable roof Exterior arcade: vertical wood siding, brick floor	See Site Significance	See Site Integrity
Upper Lake (1850s)	Yes	Landscaping and fountains originally installed by Tevis	See Site Significance	See Site Integrity	Yes	Landscape, water system & fountain added by Tevis	See Site Significance	See Site Integrity	Yes	Started as mill pond Common element in subsequent periods Road leads around lake at north and east	See Site Significance	See Site Integrity
St. Joseph Shrine (Alcove / Picnic Area) (Alma College)	Yes	Area at shrine is referred to as Picnic Area Brick arched alcove & masonry pedestal Open area Three brick steps Masonry rock wall Brick & masonry Intact	See Site Significance	See Site Integrity	Yes	Area at shrine is referred to as Picnic Area Brick arched alcove & masonry pedestal Open area Three brick steps Masonry rock wall Brick & masonry Intact	See Site Significance	See Site Integrity	Yes	Brick arched panel Rough stone walls	See Site Significance	See Site Integrity
Lily Pond/Roman Plunge (Tevis, Alma College)	Yes	Roman plunge style swimming pool by Tevis			Yes	Roman plunge style swimming pool by Tevis			Yes	Lily Pond designed by George Kelham included plinth, low brick walls, fronted by open lawn, added later - brick pergola at east end, Roman Plunge swimming pool		
Large Wooden Cross (Alma College)	No				No				No			
Concrete Fountain (Tevis, Alma College)	No				No				Yes	Originally sunken pool, replaced by Tevis with raised stone pool		
Retaining Walls (Tevis, Alma College)	No				No				Yes	Concrete and brick retaining wall north of campus including arched portion with water system Concrete foundation wall at Tevis ruin Rough stone retaining wall east of campus Massive reinforced concrete retaining wall with arch/pools (used to move water from north to north side of estate) Brick retaining walls south of lower road		
Radio Tower (1934)	Yes	Small cabin near tower (now gone) built to house radio equipment 30 feet high Metal tripod construction with ladder Fallen over			No				No			

Element	Los Gatos Country Club EIR, Appendix G: Historical & Architectural Evaluation (Archives & Architecture, February 24, 1995)				Department of Parks and Recreation 523 Forms (Archives & Architecture, June 10, 2004)				Historic Resource Study: Alma College, Los Gatos, CA (Page & Turnbull, November 2005)			
	Mention	Description & Characteristics Cited	Significance	Integrity	Mention	Description & Features Cited	Significance	Integrity	Mention	Description & Features Cited	Significance	Integrity
Bridge (1923)	Yes	Designed and built by John G. McMillan Pratt truss; Deck missing	NR Criteria C - Individually eligible as rare example of Pratt Truss by McMillan	Yes Bents and Truss	Yes	Designed and built by John G. McMillan Pratt truss; Deck missing Reinforced concrete abutments Concrete bent at each end	NR Criteria C - Individually eligible as rare example of Pratt Truss by McMillan	Yes Bents and Truss	No			
Garage/ Residence (1940s)	Yes	Two-story, built into side of hill Upper floor garage Lower floor living quarters Low-pitched gable roof with un-enclosed eaves Four stalls divided by brick pillars Lower floor constructed of poured concrete Poor Condition			Yes	Two-story, built into side of hill Upper floor garage Lower floor living quarters Low-pitched gable roof with un-enclosed eaves Four stalls divided by brick pillars Lower floor constructed of poured concrete Small gabled entrance Stair down hillside to entrance Poor Condition			Yes	Two-story, built into side of hill Upper floor garage Lower floor living quarters Low-pitched gable roof with asphalt-shingles Four stalls divided by brick pillars Lower floor constructed of poured concrete Poor Condition		
Marian Shrine (Alma College)	No				No				Yes	Wood shrine across from Library	Insubstantial, requires more research to determine significance	
Dormitories (Alma College)	Yes	Demolished in 1969.			Yes	Demolished in 1969.			Yes	Open storage structures noted to exist at the site of the old dormitories	Insubstantial, requires more research to determine significance	
Wood Shed (Alma College)	No				No				Yes	Wood shed near Upper Lake	Insubstantial, requires more research to determine significance	
Tevis House / Faculty Residence (Carport ruin) (1909)	Yes	Destroyed by fire in 1970.			Yes	Destroyed by fire in 1970.			Yes	Destroyed by fire in 1970 only northeast carport next to rough stone retaining wall remains	Insubstantial, requires more research to determine significance	



# KnappARCHITECTS

March 2010

Alma College Conditions Assessment  
Phase I - Assessment of Existing Conditions  
Section F - Cultural Landscape Analysis

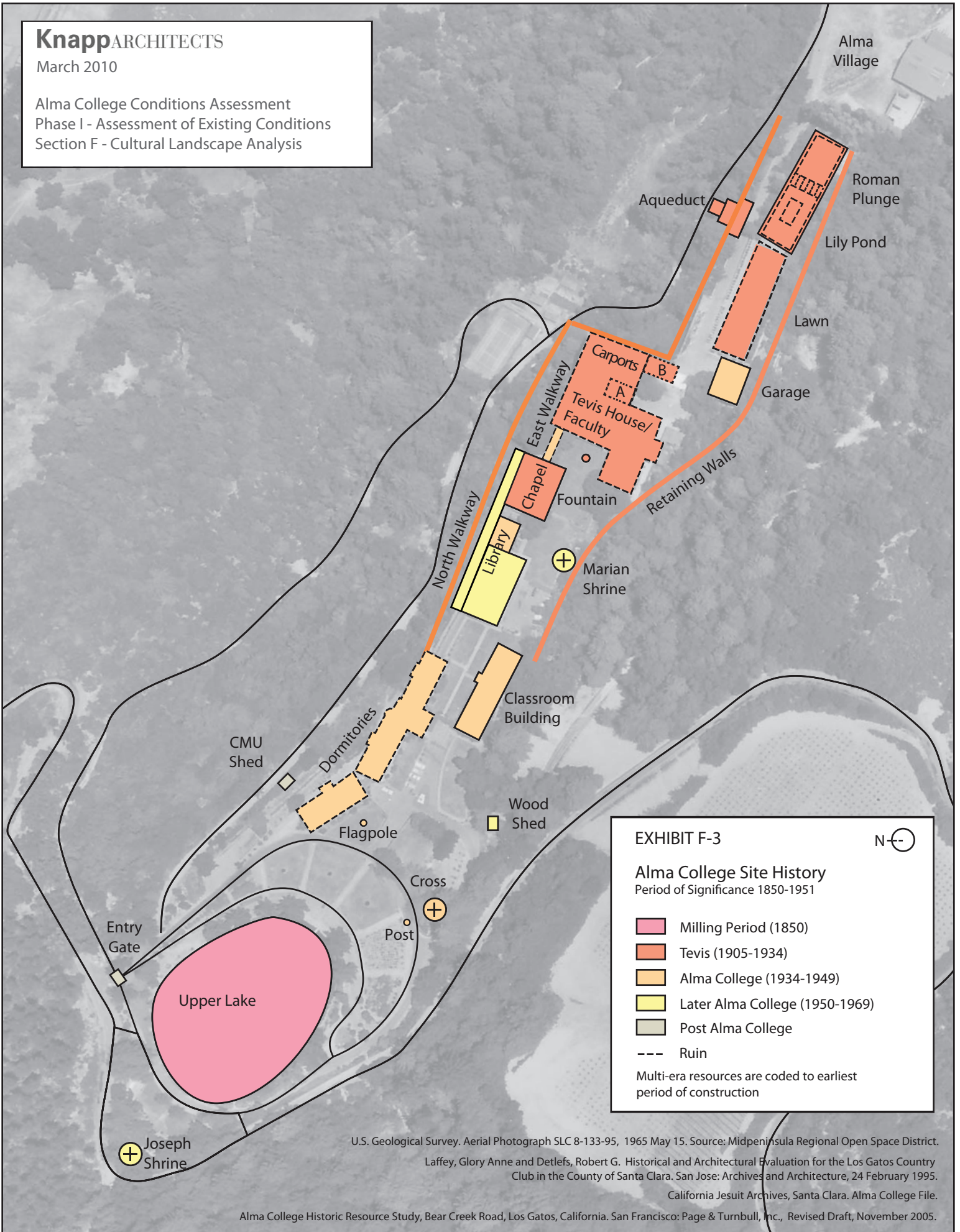

U.S. Geological Survey. Aerial Photograph SLC 8-133-95, 1965 May 15. Source: Midpeninsula Regional Open Space District.

Laffey, Glory Anne and Detlefs, Robert G. Historical and Architectural Evaluation for the Los Gatos Country Club in the County of Santa Clara. San Jose: Archives and Architecture, 24 February 1995.

California Jesuit Archives, Santa Clara. Alma College File.

Alma College Historic Resource Study, Bear Creek Road, Los Gatos, California. San Francisco: Page & Turnbull, Inc., Revised Draft, November 2005.



# KnappARCHITECTS

March 2010

Alma College Conditions Assessment  
Phase I - Assessment of Existing Conditions  
Section F - Cultural Landscape Analysis

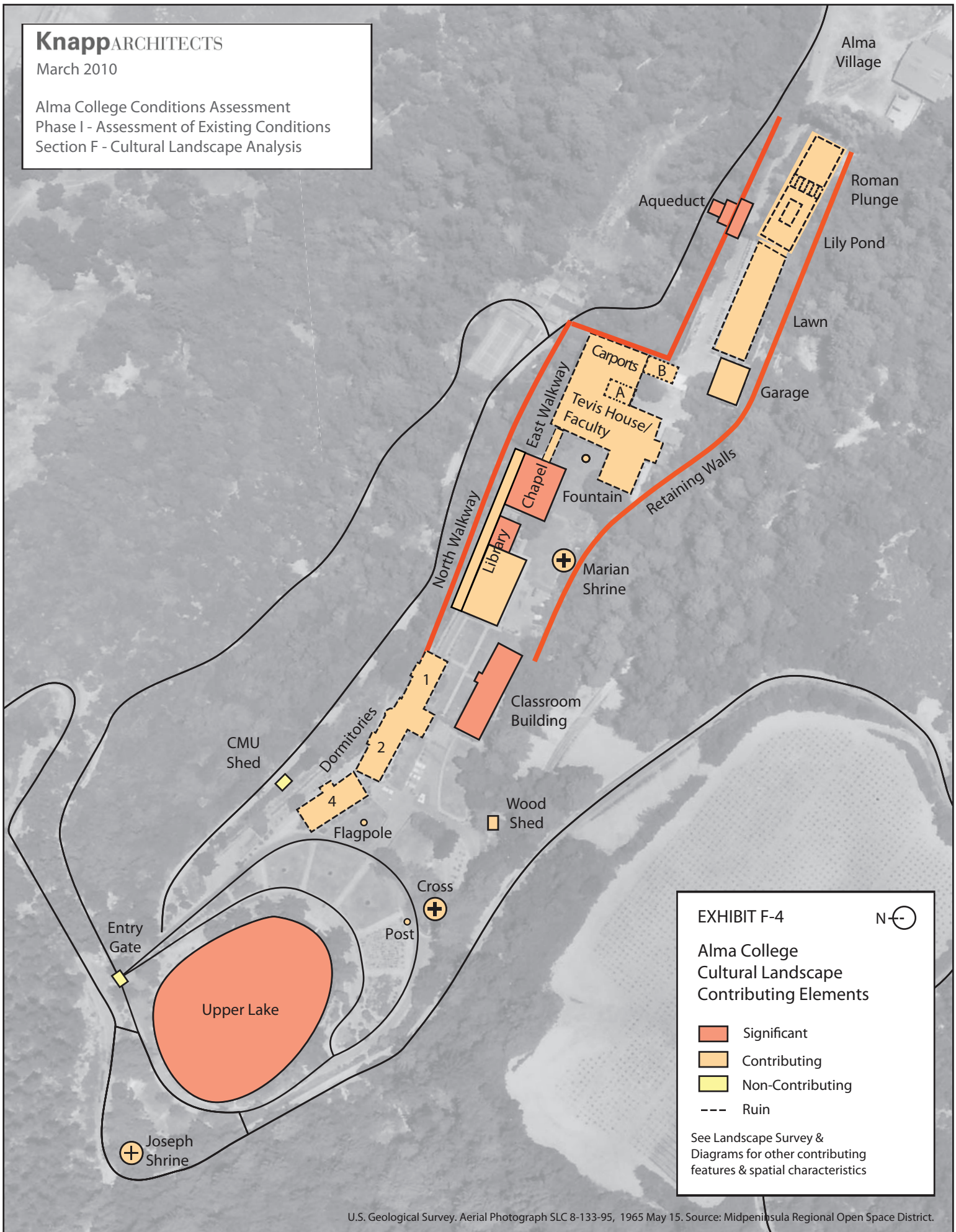

EXHIBIT F-4



## Alma College Cultural Landscape Contributing Elements

- Significant
- Contributing
- Non-Contributing
- Ruin

See Landscape Survey & Diagrams for other contributing features & spatial characteristics

**II. ASSESSMENTS & ANALYSES**  
**SECTION G - FUTURE DEVELOPMENT CONSIDERATIONS**

Exhibit G-1. Considerations for Future Use



---

**II. ASSESSMENTS & ANALYSES**  
**SECTION G - FUTURE DEVELOPMENT CONSIDERATIONS**

---

The Phase I analysis establishes the basic existing condition, adaptability, overall significance and integrity of buildings, features, and the landscape on the Alma College site (See Exhibit G-1: Considerations for Future Use and Exhibit D-3: Alma College Conditions & Adaptability). In Phase II, the project team and the District will review these factors to determine and prioritize treatment of the site and level of consideration assigned to each structure and feature in accordance with the Midpeninsula Regional Open Space District's short- and long-term planning goals and feasibility of a treatment plan. This section discusses future development considerations as a departure point for Phase II.

The Alma College cultural landscape evidences a number of distinct periods. If all features of any one period were lost, then it would be impossible to understand the site's association with that period, removing its contribution to the significance of the site. It is important, then, to consider the retention and demolition of structures and features carefully.

**Public Considerations**

Future development considerations are influenced by the community and various public bodies. The local community recognizes and values the Alma College site and is interested in its future treatment. On a basic level, the site's rich history lends itself to interpretation. More complex uses are possible for the site, to utilize its buildings, landscape, and features for group and school sponsored events, outside vendors such as a wine-tasting facility, and in-house uses by the District.

The goals of the Midpeninsula Regional Open Space District are important parameters for planning future treatment of the site. It is the goal of MROSD to maintain open space and cultural resources therein for the use and recreation of the public. Historical and cultural significance is important in District decision-making. The District values roads, trails and shade in the planning of the site. The Alma College cultural landscape is viewed by the District as a major trailhead into the open space preserve and is expected to have high use. Future use is also influenced by the Draft Sierra Azul / Bear Creek Redwoods Master Plan that may indicate uses for the site which would change how the site is viewed and which buildings would remain.

Santa Clara County regards the site as a historic resource, eligible to the California Register. As such, a proposed project altering the site would be evaluated under county historic resources policies including demolition review by the Historical Heritage Commission (HHC) and the Board of Supervisors per Santa Clara County Code, Article 7, Section C1-91.

A separate review process for the California Environmental Quality Act (CEQA) is required to determine whether a proposed project has an adverse impact on a historic resource in relation to its significance and integrity. A determination of adverse effect would extend the CEQA review process. This extended process would also include public comment.



Formulated by the National Park Service, the *Secretary of the Interior's Standards* is a set of guidelines for the preservation and treatment of historic properties. The future treatment of the site is intended to comply with the *Secretary's Standards* including the rehabilitation of historic structures. Once a site use concept has been developed, the feasibility of compliance with the *Secretary's Standards* can be readily addressed. Among other potential benefits, the application of the *Secretary's Standards* can minimize the environmental review for a proposed project under CEQA.

## **Phased Development**

By identifying historic resources and evaluating their importance and condition in Phase I, the District seeks to develop a plan for their future use in Phase II. Since it would not be feasible to undertake a massive rehabilitation program to return the Alma College property to its historic condition in one stage, future development and rehabilitation may be phased into manageable stages.

The stages suggest the priority in which rehabilitation work could be performed for the overall site. Stage 1 would initiate rehabilitation of the site, focusing on vegetation management, circulation and minor stabilization of landscape elements and ruins that are not dependent on the retaining walls for support. Stage 2 work would strengthen the site retaining walls to stabilize buildings and elements that depend on the retaining walls for support. Stage 3 would rehabilitate buildings and site features including structural retrofit and architectural repairs. Stage 4 would involve the construction of necessary minor structures for support of the site or a new use.

For the rehabilitation of individual elements within these stages, including buildings and landscape features, it is more difficult to suggest clear-cut priorities in advance of basic decisions on site use and budget. The layered site history and various conditions of buildings and features presented in this report, in addition to the District's requirements and goals for management of this property, create a complex backdrop for decision-making. To assist in the decision-making process in Phase II, this report offers a tentative order (or hierarchy) in which the landscape, features, and buildings could be approached under each stage.

### Stage 1

On a basic level, the landscape and landscape elements could convey the story of the site's development to a potential visitor. As a first step, landscape features could be rehabilitated at minimal cost to begin developing the site for community use and interpretation. Landscape features could be stabilized as they exist. Deterioration of mostly intact features could be repaired and surrounding vegetation could be cut back. A myriad of historic photographs and drawings exist to provide interpretive stations throughout the site at each feature. Depending on the level of rehabilitation required by a new project, Upper Lake may be reclaimed from invading vegetation which would require additional cost to cut back invading vegetation and restore function of the fountain.

The District's basic maintenance priorities for landscape vegetation are removal of under-story vegetation (mowing) and maintaining roads and trails. The extent to which the formal landscape should be restored and how the general landscape will be treated

depends on who is doing the long-term maintenance. Allowing tenants to use the property for minimal rent in return for the management of the site has been a viable alternative at other sites. Volunteer maintenance is another possibility but involvement may fluctuate. Both options may be inadequate in terms of the skill required to maintain the landscape. Skilled arborists should have oversight of tree pruning and removal of designated underbrush.

Another basic level of restoration would be the circulation. Upper Lake is the oldest feature and a defining focus from which pedestrian paths emanate toward the campus proper. The landscape features serve as orientation points along paths and roads. Restoration of the pedestrian paths around Upper Lake and through the site would substantially increase the readability of the site's formality. Since the North and East Walkways are connected to the Chapel and Library buildings, the rehabilitation of those paths and associated structures would need to be coordinated with the building rehabilitation in Stage 3. Although it is important to retain and rehabilitate the circulation path itself, the North Walkway's lean-to roof, beams and posts of no aesthetic distinction could be demolished. The portion of the North Walkway between the Chapel and Library and the East Walkway should be considered for retention since they are visible from the main axis and provide shade.

The stabilization of building ruins, including the Tevis House / Faculty Residence, Lily Pond and Roman Plunge, could follow restoration of landscape elements. Depending on their proximity to retaining walls, certain ruins could be stabilized after the landscape elements or be done at a later stage following strengthening of the existing retaining walls which hold up the site. The carport which was part of the Tevis House/Faculty Residence and the Dormitories could be stabilized and secured as interpretive sites. The carport has a covered space, an interior space, and a lower terrace. These areas could be used for shade, picnics or other use. For the Dormitories, to reduce hazard, vegetation could be cut back, loose debris removed, and the ruins cut down to be read in plan. The retention of these ruins requires consideration of necessity and usability.

## Stage 2

The second level of rehabilitation would include retrofit of the existing retaining walls to stabilize the site. This work would precede rehabilitation of the main buildings, which depend on the retaining walls for support. Depending on the results of detailed studies in Phase II, the retrofit may be at a substantial cost but, because the walls are primary elements that contain the site, the work is critical to enable future site development.

## Stage 3

After the retrofit of existing retaining walls, a tertiary level of site development would involve building rehabilitation or consideration of demolition of the main structures that are largely intact: the Chapel, Library (1934 and 1950 structures), Classroom building and Garage / Residence. The retention and reuse of an existing building involves consideration of its condition, adaptability in terms of cost and use, and its contribution to the cultural landscape. Condition includes its physical deterioration and associated cost of repair but also its adjacency to the earthquake faults located at the site. Demolition is not uncommon in the District's open space preserves but it should be carefully considered to maintain the rich history of the Alma College cultural landscape. Various options exist for each of the intact buildings in order of significance.

Based on historic importance and contribution to the cultural landscape, the Chapel would be the first candidate for rehabilitation. The Chapel building is by far the most important building on the site because its history spans both the Tevis and Alma College periods. The retention of this building is critical to the reading of the cultural landscape and demolition would be heavily discouraged. The Chapel's adaptability is based on how it can be used, while still maintaining its character, and the cost to repair its existing conditions. Its large open interior space could serve as an assembly space, which is in line with its previous uses, rather than dividing the space with partition walls. To repair its existing conditions, rehabilitation would require a moderate level of work and expense.

The second candidate for rehabilitation is the 1934 Library. As integral part of the early campus from the Alma College period (1934-1949), the 1934 Library is closely associated with the Chapel in character. The 1934 Library is a small structure and rehabilitation may not have a substantial cost but the space may not be as adaptable as a larger one.

The Classroom building, also from the Alma College period (1934-1949), is a significant contributor to the cultural landscape, defining an edge of the internal spinal axis of the early campus. It has the most critical adjacency to geotechnical faults and, as such, cannot be made habitable. The removal of the Classroom building would have a major effect on the site. Even so, its poor physical condition and proximity to the fault may outweigh its retention. Its structure could also be cut down to foundation plan level as an interpretive site.

The 1950 Library, connected to the 1934 Library, is well documented and stable. Although its dominant presence and articulation are in contrast with the early campus period, the 1950 Library, as part of the development of the campus, is a contributing structure. As a large structure, the 1950 Library could be highly adaptable to a new use. Partition walls similar in height to library stacks could provide division of the main level space. The space could be used for assembly or as an interpretive museum with displays of the site's historic photographs and drawings. Lower level spaces could be used for offices or support areas. Though structural retrofitting, re-roofing and finish work for a large building may have a substantial cost, in comparison to the Chapel and 1934 Library, it would have a lower square foot cost. Even so, if frequency of use does not warrant the cost of rehabilitation, continuous use, and regular maintenance, the building may have a high long-term cost for little benefit.

Since the Garage/Residence is utilitarian building and not a primary contributor to the reading of the cultural landscape, it could be a candidate for demolition with careful consideration of the portion of the structure retaining grade along the steep slope. The Garage/Residence is set within the fault zone similarly to the Classroom building and cannot be habitable. Further study would need to be done to determine to what level the Garage/Residence would require retrofit to stabilize the building, footings and, retaining structure.

#### Stage 4

In keeping with its land management goals, it is unlikely that the District would construct a major new structure or allow a tenant to undertake major construction at the site. It is likely that new structures would be built for support of the site as an open space

property, for example, a bathroom facility. Another option could be constructing a minor new building, funded by outside developers, to bring a new commercial use to the site without prohibiting open space recreational uses and interpretation of the cultural landscape. A new building could be constructed on the site of existing ruins, such as that of the Dormitory buildings, in a manner that does not diminish the cultural landscape. A new structure could also restore missing edges of the site that were lost through demolition. A new structure would require geotechnical and structural considerations for the soils and seismic zone, and a setback from identified faults and those to be identified.

### **Factors in Planning for Future Use**

Future use and cost are major factors in determining both the demolition of structures and their retention and reuse. What the site is used for and how often it is used will determine what functions can be housed and will have the best cost/benefit for the site. Indigenous bat and rodent populations should be identified and quantified. New work on the site should consider mitigation in regard to affected populations. Utilities infrastructure is a major component for reuse of the site. Funding will affect the level of rehabilitation possible, ranging from grants to private sources. Although elimination of features of low integrity or of less significance could reduce the cost of a development project, all the critical factors should be weighed before a future use is developed. It is then paramount that the following be considered to determine future treatment of the site as developed in Phase II:

1. The significance of elements contributing to the cultural landscape including buildings, landscape features, circulation, topography, spatial relationships, and vegetation.
2. Condition and cost of rehabilitation of buildings, landscape and landscape features.
3. Priorities established by the District and Draft Sierra Azul / Bear Creek Redwoods Master Plan including safety, connection to trails and overall planning considerations.
4. Building use and frequency of use.
5. Current code requirements including accessibility and utilities infrastructure required by a new use.
6. Effect of future plan on indigenous animal life such as bats.
7. Amount and sources of funding required to pursue rehabilitation.

These factors must be balanced to extract the maximum value from the site.





This chart summarizes the considerations involved in planning for the future use of the Alma College site, which is considered eligible under Criteria 1 of the California Register as a cultural landscape, a type of historic district. The chart lists the elements of the site, their existing condition, adaptability, and significance as evaluated for this study. It also notes the opportunities and constraints in regard to each element and to what degree demolition or selective demolition of an element would affect the cultural landscape and diminish its integrity.

See Exhibit D-1.1 for Architectural Survey & Analysis Key for Abbreviations

ELEMENT	Geotechnical Condition	Structural Condition	Architectural Condition	Landscape Condition	Overall Adaptability	Significance to the Alma College Cultural Landscape	OPPORTUNITIES	CONSTRAINTS	EFFECT OF DEMOLITION ON THE ALMA COLLEGE CULTURAL LANDSCAPE
Site Overall (1850s to the present)	P	P	P	P	1	1850-1951	Maintain discrete character-defining landscape features as a first step. Retain existing structures and features that express the layers of history.	Consider earthquake faults. Fall hazard at retaining structures. Manage introduced & native species to read landscape. Reinstate pedestrian circulation spine through site. Reinstate & maintain spatial arrangement and enclosure by buildings and vegetation. Develop site drainage to limit runoff & direct water away from buildings. Restore site utilities & infrastructure - water, sewer, electricity, roads and parking.	Overall Demolition: Major Effect. Selective Demolition: The Alma College cultural landscape evidences a number of distinct periods. If all features of any one period were lost, it would be impossible to understand the site's association with that period, removing its contribution to the significance of the site. It is important to carefully consider the retention and demolition of structures and features based on overall significance to the cultural landscape, existing condition, and risk of hazard. Selective Demolition would be a minor effect if carefully tailored.
Chapel (1909/1934)	F	F	F	N/A	2	S	Large interior primary space. West addition secondary space. Large paved veranda at north - shaded area.	Seismic retrofit. Soil failure / landslide at northeast. Basement, possible abandonment. Stair, rebuild or remove. Bat population within building.	Overall Demolition: Major Effect. Selective Demolition: Minor Effect. Stair could be demolished and lower level could be abandoned or infilled depending on closer structural evaluation.
Library (1934)	F	F	F	N/A	2	S	Double-height space with upper and lower windows. Remove non-historic interior loft, kitchen & stair to restore double-height space.	Seismic Retrofit. Reroofing.	Overall Demolition: Major Effect. Selective Demolition: Interior non-historic materials could be demolished.
Library (1950)	G	G	F	N/A	1	C	Most intact and stable building. Large interior upper space usable for large meeting rooms or low-partition divided office space similar to library stacks. Basement usable for classes, offices, storage.	Seismic retrofit. Reroofing. Long-term maintenance.	Overall Demolition: Minor Effect. Although it contributes to the cultural landscape, the building could be demolished since it has a secondary role in the original plan of the campus.
Classroom Building (1934)	P	P	F	N/A	3	S	Reinforces visual enclosure of site. Interpretive value. Large storage space.	Adjacent to earthquake faults. Non-habitable uses only. Seismic retrofit. Rehabilitate exterior finish materials.	Overall Demolition: Major Effect. Although the effect on the cultural landscape would be major, the proximity to faults, level of seismic retrofit required & vulnerability as a non-habitable building to vandalism make an argument for overall demolition.
Garage/ Residence (1940s)	P	P	F	N/A	3	C	Parking at upper level. Storage space at lower level.	Adjacent to earthquake faults. Non-habitable uses only. Topographic issues, steep grade. Seismic retrofit. Exterior Stair needs rebuilding. Reroofing. Rehabilitate exterior finish materials.	Overall Demolition: Minor Effect. The proximity to faults, level of seismic retrofit required & vulnerability as a non-habitable building to vandalism make an argument for demolition. The garage is integral with a retaining wall and demolition may not be possible.
Dormitories	NE	NE	P	N/A	4	C	Interpretive value as ruin. Planted area to express height & enclosure of original campus.	Ruin, Minor stabilization. Ruins would need to be assessed for access & hazard reduction.	Overall Demolition: Minor Effect. The removal of these ruins would affect the interpretive value of the site but if the ruin poses a hazard, demolition could be considered.
Tevis House / Faculty Residence ruin including carport structure	NE	NE	P	N/A	4	C	Interpretive value as ruin, two layers of history. Carport A - parking, or shaded area. Carport B - parking area or shaded area.	Ruin, Minor stabilization. Adjacent to retaining wall, fall hazard.	Overall Demolition: Major Effect. Carport A ruin is part of both the Tevis and Alma College periods. Its demolition would diminish the interpretive value of the site. This carport and its lower terrace are integral with a retaining wall and removal might be detrimental to site stability. Selective Demolition: Carport B is less character-defining, its pillars and roof may be demolished if they are not integral with the retaining wall.
Wood Shed	NE	NE	P	N/A	2	C	Interpretive value.	Adjacent to earthquake faults. Non-habitable uses only. Stabilize walls and provide adequate foundations.	Overall Demolition: Minor Effect. Since its history is not documented, it is not clear when the shed was built and what importance it has. It does have some design & workmanship similar to the oldest buildings on the site and has some aesthetic value.
North Covered Walkway at Chapel & Library Buildings	P	NE	P - roof, post, beams	N/A	3	C	Interpretive value. Restore clay tile and veranda railing at chapel. Shaded area.	Seismic retrofit. Walkway roof imposes load on Chapel and Library roofs, obscuring features. Covered walkway & wood flooring require rehabilitation or rebuilding. Walkway posts are connected to retaining wall.	Overall Demolition: Major Effect. Complete removal of a major circulation path that extended from the Chapel to the Dormitories would be a major effect. Historically, this walkway was visible between buildings from the main campus axis. Now, only a portion remains adjacent to the Library and Chapel. Demolition would also remove effective shaded areas between buildings. Selective Demolition: Although it is important to retain and rehabilitate the circulation path itself, the walkway's lean-to roof, beams and posts of no aesthetic distinction could be demolished. The portions which remain between buildings should be considered for retention since they are visible from the main axis and provide shade.
East Walkway from Chapel to Tevis House / Faculty Residence Ruin	NE	NE	P	N/A	3	C	Interpretive value. Rebuild portion existing at chapel. Rebuilding part of walkway or all of it would provide shaded area.	Deteriorated wood floor planking and subfloor at walkway are hazardous. Adjacent to retaining wall, fall hazard.	Overall Demolition: Major Effect. This walkway is visible from the main axis of the campus. The walkway has character-defining features that reflect those in historic photographs. It is an example of a major site pedestrian path.
Retaining Walls / Aqueduct	F	F	F	F	3	S	Interpretive value. Supports site.	Fall hazard. Requires structural/geotechnical testing. Structural retrofit. Introduction of drainage to reduce hydrostatic pressure.	Overall Demolition: Major Effect. The retaining walls are structural necessities for support of the site, aesthetic features and literally define the boundaries of the site. Their removal would be detrimental to the cultural landscape.
Upper Lake (renovated in 1920's)	N/A	N/A	N/A	F	3	S	Interpretive value. Restore fountain function. Restore circulation around lake. Water for fire suppression & irrigation.	Substantial restoration required to remove vegetation and repair fountain operation. Long-term maintenance of vegetation.	Overall Demolition: Major Effect. The oldest and most primary element of the site. Demolition would be detrimental to the cultural landscape.

ELEMENT	Geotechnical Condition	Structural Condition	Architectural Condition	Landscape Condition	Overall Adaptability	Significance to the Alma College Cultural Landscape	OPPORTUNITIES	CONSTRAINTS	EFFECT OF DEMOLITION ON THE ALMA COLLEGE CULTURAL LANDSCAPE
St. Joseph Shrine	N/A	NE	NE	G	1	C	Interpretive value. Element of orientation. Shaded area surrounding shrine. Restore visual connection to Upper Lake.	Minor stabilization. Long-term maintenance of vegetation.	Overall Demolition: Major Effect. One of the many smaller elements that provide a notion of the site's history. The landscape elements are an important part of the cultural landscape. Demolition would diminish the character of the site.
Marian Shrine	N/A	NE	NE	F	1	C	Interpretive value. Element of orientation. Shade of trees adjacent to shrine.	Minor stabilization. Long-term maintenance of vegetation.	Overall Demolition: Major Effect. See St. Joseph Shrine description.
Field/Lily Pond/Roman Plunge	N/A	NE	NE	P	4	C	Interpretive value. Shaded area surrounding feature. Reinstate field, Lily Pond & Plunge as open area.	Ruin, Minor stabilization Long-term maintenance of vegetation	Overall Demolition: Major One of integral landscape features of the site with two layers of history. Demolition of the remaining portions would be detrimental to the cultural landscape.
Large Wooden Cross	N/A	NE	NE	F	1	C	Interpretive value. Element of orientation. Restore existing hedge at cross layout.	Minor stabilization. Long-term maintenance of vegetation.	Overall Demolition: Major Effect. See St. Joseph Shrine description.
Concrete Fountain Basin	N/A	N/A	NE	P	4	C	Interpretive value. Element of orientation. Restore and reuse basin. Shaded area adjacent to basin.	Ruin, Minor stabilization. Long-term maintenance of vegetation.	Overall Demolition: Major Effect. See St. Joseph Shrine description.
Flagpole	NE	NE	NE	F	1	C	Interpretive value. Element of orientation.	Minor stabilization.	Overall Demolition: Minor Effect.
Post	N/A	N/A	NE	F	1	C	Interpretive value.	Minor stabilization.	Overall Demolition: Minor Effect.
New Structure	NE	NE	NE	NE	3	N/A	Possible locations: Site of Dormitories or Tevis House / Faculty Residence ruins.	Minimum 50 ft distance from earthquake faults. Site investigation for trace faults. Test soils for bearing capacity, settlement, sliding, expansive soil, collapsible soil.	N/A

### **III. CONCLUSION**





---

### **III. CONCLUSION**

---

#### **Phase I – Assessment of Existing Conditions**

The Phase I conditions assessment has established the existing conditions of the Alma College site, its eligibility as cultural landscape and future development considerations. The Alma College landscape and its extant structures and features require varying levels of invasive rehabilitation, vegetation management, and maintenance.

The Alma College site is eligible to the California Register under Criterion 1 as a cultural landscape, which is defined under the category of district. The site is significant for its layers of development, which parallel that of California history. This study defines the period of significance as circa 1850 to 1951. Despite the loss of buildings and features and lack of maintenance, the Alma College site retains integrity. Additional research and processing of formal documentation by a landscape historian is recommended for a California Register nomination as a district.

Planning for future rehabilitation and development should consider the site's significance. The Alma College cultural landscape evidences a number of distinct periods. If all features of any one period were lost, then it would be impossible to understand the site's association with that period, removing its contribution to the significance of the site.

Future development of the site should be phased into manageable stages beginning with rehabilitation of the landscape and its features, then strengthening of site retaining walls, rehabilitation of buildings and construction of necessary new structures.

#### **Phase II - Preparation of Treatment Recommendations**

The main purpose of Phase II is to develop treatment recommendations for the site's buildings and features with cost estimates. Phase II options for future use would be based on the defined cultural landscape and stay within the mission of the Midpeninsula Regional Open Space District. The District would interact with and provide direction to the project team on the level of detail and attention paid to each of the site features. In Phase II, the architect, landscape architect, geotechnical and structural engineers would provide information to the cost estimator. The project team would do additional investigation of structures and retaining walls as necessary to refine the treatment recommendations and cost estimation. A bat biologist would review the plans and provide a summary to address mitigation for the indigenous bat populations which exist in more than one building.

Potential funding sources would also be identified. Since the District depends on funding for improvement projects, options that would close the door on grants or foundation funding would need to be identified. For example, Santa Clara County does not encourage demolition of historic resources and would not fund such projects. An implementation plan would be developed to include a list of features, deterioration and a schedule for short- and long-term tasks including inspections of the site.

### **Phase III - Final Report Preparation**

Phase III would compile the findings and recommendations of Phase I and II. The project team would confer with the District to clarify a draft of the report for finalization. The final report would be submitted to the District's Board of Directors for review and comment. The project team would participate in meetings with the District and the Board of Directors to address development and feasibility of rehabilitation in terms of cost and benefit.

The Alma College cultural landscape is rich in history and resource variety, and has great potential as a valuable interpretive site. The purpose of the Alma College Conditions Assessment is to provide practical information to determine the future treatment of this resource with the goal of enhancing its historic value and its value to the community.

#### **IV. BIBLIOGRAPHY**





---

**IV. BIBLIOGRAPHY**

---

Alma College Photographic Color Slide Scans. Provided by Midpeninsula Regional Open Space District.

Baker, Jim. Santa Clara County Geologist. Correspondence with Chris Hundemer of Treadwell & Rollo, 31 July 2009 interview by telephone and 6 August 2009 email to Chris Hundemer containing relevant documents for review.

Baker, Jim. Santa Clara County Geologist. Review Comments for Land Use Application, CPO Record No. 18980, 1997.

Birnbaum, Charles A. ed. *The Secretary of the Interior's Standards for the Treatment of Historic Properties with Guidelines for the Treatment of Cultural Landscapes*. Washington DC: United States Department of the Interior. National Park Service. Heritage Preservation Series, 1996.

Blake, Philip C., S.J. "Alma Through the Years: A Pictorial History of the 'Alma Dale' Estate." *Eden, Journal of the California Garden & Landscape History Society*, Fall 2006. Reprinted and edited version of article originally published in *Western Jesuit* 35, No. 3, February, 1960, p. 4-17.

Boutelle, Sara Holmes. *Julia Morgan Architect*. New York: Cross River Press, 1988.

Brabb, Earl E. and Dibblee, T. W., Jr. *Preliminary Geologic Map of the Los Gatos Quadrangle, Santa Clara and Santa Cruz Counties, California*. U. S. Geological Survey, Open File Map 78-453, 1:24,000, 1978.

Brabb, Earl E. and Dibblee, T. W., Jr. *Preliminary Geologic Map of the Castle Rock Ridge Quadrangle, Santa Cruz and Santa Clara Counties, California*. U. S. Geological Survey, Open File Report 79-659, 1:24,000, 1979.

California Division of Mines and Geology. *Guidelines for Evaluating and Mitigating Seismic Hazards in California*. Special Publication 117, 1997.

California Division of Mines and Geology. *Probabilistic Seismic Hazard Assessment for the State of California*. CDMG Open-File Report 96-08, 1996.

California Division of Mines and Geology. *Seismic Hazard Zone Report for the Los Gatos 7.5-Minute Quadrangle, Santa Clara County California*. California Department of Conservation, Division of Mines and Geology, Seismic Hazard Zone Report 069, 2002.

California Division of Mines and Geology. *State of California Special Studies Zone Map, Castle Rock Ridge 7½-Minute Quadrangle*. 1:24,000, 1974.

California Division of Mines and Geology. *State of California Special Studies Zone Map, Los Gatos 7½-Minute Quadrangle*. 1:24,000, 1991.

California Jesuit Archives, Santa Clara. Alma College File. House history, photographs and drawings.

- Cao, T., Bryant, W. A., Rowshandel, B., Branum, D. and Wills, C. J. "The Revised 2002 California Probabilistic Seismic Hazard Maps," 2003.
- Hundemer, Christopher and Gouchon, John. Senior Geologist and Principal at Treadwell & Rollo, Inc. Letter to Frederic Knapp, Knapp Architects. San Jose, 2 October 2009.
- Kenyon, Ken. California Polytechnic State University. Special Collections and University Archives. Robert E. Kennedy Library. Interview by telephone regarding Julia Morgan Papers, 1835-1958, 5 October 2009.
- John Coyle & Associates, Inc. *Preliminary Fault Location Study, A Portion of Alma College Grounds, Los Gatos Country Club, 19380 Bear Creek Road, Santa Clara County, California*. Consultant's report, 1997.
- John Coyle & Associates, Inc. *Letter of Clarification, Preliminary Fault Location Study, A Portion of Alma College Grounds, Los Gatos Country Club, 19380 Bear Creek Road, Santa Clara County, California*. Consultant's supplemental letter, 1997.
- Laffey, Glory Anne and Detlefs, Robert G. *Historical and Architectural Evaluation for the Los Gatos Country Club in the County of Santa Clara*. San Jose, California: Archives & Architecture, 24 February 1995. Published in the *Los Gatos Country Club Environmental Impact Report, Appendix G*.
- MacGregor, Bruce A. *South Pacific Coast*. Berkeley: Howell-North Books, 1968.
- Maggi, Franklin and Duval, Charlene. Archives & Architecture. *Department of Parks and Recreation 523 Forms: SCL515 Alma College Complex, Santa Clara County*. Campbell, California, 10 June 2004.
- McLaughlin, R. J.; Clark, J. C.; Brabb, E. E.; Helley, E. J.; and Colón, C.J. *Geologic Maps and Structure Sections of the Southwestern Santa Clara Valley and Southern Santa Cruz Mountains, Santa Clara and Santa Cruz Counties, California*. U. S. Geological Survey, Miscellaneous Field Studies Map MF-2373, 2001.
- Midpeninsula Regional Open Space District. "Alma College Site Plan: Bear Creek Redwoods Open Space Preserve." Los Altos, California, June 2009.
- Midpeninsula Regional Open Space District. "Request for Proposals for Historical Architectural Consulting Services: Alma College Conditions Assessment Project." Los Altos, California, 23 March 2009.
- Office of Historic Preservation. *Instructions for Recording Historical Resources*. Sacramento, California, March 1995, pp. 2-3.
- Page, Robert R.; Gilbert, Cathy A.; and Susan A. Dolan. *Guide to Cultural Landscape Reports: Contents, Process, and Techniques*. Washington DC: United States Department of the Interior, National Park Service, Park Historic Structures and Cultural Landscapes Program, 1998.

- Page & Turnbull, Inc. *Alma College Historic Resource Study, Bear Creek Road, Los Gatos, California*. San Francisco, California, Revised Draft, November 2005.
- Park, Keith W. "Alma College Ornamental Plant Resource Inventory," Alma College volunteer horticulturalist, 22 July 2009.
- Peak, Dana. Historical Heritage Commission Program Manager, Santa Clara County Planning Office, California, Interview by telephone, 1 October 2009.
- Peterson, Br. Daniel J., S.J. Archivist, California Province, Society of Jesus Los Gatos, California. Email correspondence with Ruchira Nageswaran of Knapp Architects, 7 October 2009 and 22 October 2009.
- Questa Engineering Corporation. Response letter to Santa Clara Valley Water District review letter. 21 April 1998.
- Santa Clara County, California. Department of Planning and Development. Planning Office. Santa Clara County Heritage Resource Inventory.
- Santa Clara Valley Water District. Geologic review letter for proposed Los Gatos Country Club development. 16 April 1998.
- Sarna-Wojicki, A. M.; Pampeyan, E. H.; and Hall, N. T. *Maps Showing Recently Active Breaks Along the San Andreas Fault Between the Central Santa Cruz Mountains and the Northern Gabilan Range, California*. U. S. Geological Survey Miscellaneous Field Studies Map MF-650, 2 plates, 1:24,000, 1975.
- Schmidt, K. M.; Ellen, S. D.; Haugerud, R. A.; and Peterson, D. M. *Map of Pavement and Pipe Breaks as Indicators of Range Front Faulting Resulting from the 1989 Loma Prieta Earthquake*. U. S. Geological Survey, Open-File Report 95-820, 1995.
- U. S. Geological Survey. Aerial Photograph SLC 8-133-95, 15 May 1965. Provided by Midpeninsula Regional Open Space District.
- Wesnousky, S. G. "Earthquakes, Quaternary Faults, and Seismic Hazards in California." *Journal of Geophysical Research*, 91(1312), 1986.
- William Lettis and Associates. *Geomorphic Investigations of Deformation Along the Northeastern Margin of the Santa Cruz Mountains*. U. S. Geological Survey Open-File Report 94-187, 1994.
- Working Group on California Earthquake Probabilities (WGCEP). "The Uniform California Earthquake Rupture Forecast, Version 2." Open File Report 2007-1437, 2007.



